

Instruction- and Maintenance Manual Super Boom Lift

Document Number:
ED.03622.00.001.R03.ENG

Status:
Final

Original instructions

SBL1100 / SBL900

*1068 / 915 metric ton
hydraulic portal lift system*



ENERPAC 
HEAVY LIFTING TECHNOLOGY 

www.enerpac.com

Revisions

Rev	Description	Date	Author	Checked	Approved by
00	Initial version	23 March 2017	D. Rosier	Th. Westerhof B. Geerdink A. Holterman	R. Broenink
01	Added: <ul style="list-style-type: none"> - Transporting frame - Index table - Document lined up with other Gantry manuals: - Pictures and illustrations - Standardized texts - ASME B30 implemented 	9 May 2017	D. Rosier	R. Bosman R. Corbeek	R. Broenink
02	On request of Reinder Hilarius: <ul style="list-style-type: none"> - Safety sheets should be of the same manufacturer as the type of hydraulic oil (Shell) - Add safety data sheets for all other prescribed lubricants (Kroon oil) On request of Ruben Bosman: minimum operating temperature set to -10 degrees	19 July 2017	D. Rosier		R. Broenink
03	<ul style="list-style-type: none"> - Changed the extending time during lifting and added the retracting time during lowering of the load. - New front page. - Remote control: explanation arrows. - Editorial changes. - Safety data sheet HF95 hydraulic oil. - Added Section 7.2 Warning Signs 	13 March 2018	R. Corbeek	R. Broenink	R. Broenink
04	<ul style="list-style-type: none"> - Tracks alignment requirements changed. - Additional lubrication of the running surfaces of the booms within the chapter "maintenance". 	15 March 2018	R. Corbeek	R. Broenink	R. Broenink

Preface

Dear customer,

This is the manual for assembling, using and maintaining of both the SBL1100 and the SBL900 Super Boom Lift systems. In this manual, those machines are referred to by the term “**System**”.

The manual is meant to be used by operators and by maintenance engineers.



It is essential that the user reads this manual completely **before** start working with the System.

- All information, illustrations and technical data in this manual are applicable to the System as it was at the **time of issuing** of this manual.
- We continuously **improve** our products and therefore reserve the right to implement improvements and **changes** whenever it is necessary and possible to do so, without any obligation to apply improvements or changes to models purchased previously. Nevertheless, when the system is improved due to serious **safety issues**, you as a customer will be informed.
- If this manual becomes **unreadable**, in whole or in part, you can order a copy by providing us the number given on the front cover.
- Despite the fact that this manual has been drafted with great care, we **cannot guarantee** that it does not contain any errors.
- The use and interpretation of all information in this manual and the possible consequences through improper use of the system are wholly the **responsibility of the user**. Enerpac shall under no circumstances accept any responsibility for such improper use.

Pictures and illustrations in this manual may differ from reality.

Within this document use is made of **structured text**. The following conventions are applied:

- Procedural steps are numbered. Execute the steps sequentially. Do not skip any step.
- Responses of the system are written on the next line in italic font
- Choices are indicated with bullets.

Example:

1. Press the button
The indicator turns green
2. Click on the square icon
The system starts moving
3. Select one of the following options:
 - Click the red icon for lifting
 - Click the green icon for lowering
 - Click the blue icon for ending the operation

© All rights reserved. Nothing in this publication may be duplicated, stored in an automated database or made public in any form or in any manner, whether electronic, mechanical, by photocopying, recording or any other means, without prior written approval by Enerpac.
--

We hope this manual will help you to use the System properly.

Enerpac.

Contents

- Preface** _____ **3**
- Contents** _____ **4**
- 1. Introduction** _____ **7**
 - 1.1. Manufacturer address** _____ **7**
 - 1.2. Declaration** _____ **7**
 - 1.3. Referenced documents** _____ **7**
 - 1.4. Identification** _____ **7**
 - 1.5. Liability** _____ **8**
 - 1.6. Intended use** _____ **8**
 - 1.7. Modifications** _____ **8**
 - 1.8. Personnel and obligations** _____ **9**
 - 1.9. Lifetime** _____ **13**
 - 1.10. Warning symbols used within this document** _____ **14**
- 2. General safety aspects** _____ **15**
 - 2.1. Mandatory protective gear** _____ **15**
 - 2.2. General safety regulations** _____ **16**
 - 2.3. Symbols applied to the System** _____ **17**
 - 2.4. Welding work** _____ **19**
 - 2.5. Working on the electrical system** _____ **19**
 - 2.6. Working on the hydraulic system** _____ **19**
 - 2.7. Fire** _____ **19**
 - 2.8. Working with hazardous substances** _____ **20**
 - 2.9. Assembly and disassembly** _____ **23**
 - 2.10. Transport, loading and unloading of the System** _____ **23**
- 3. System Overview** _____ **24**
 - 3.1. General** _____ **24**
 - 3.2. System specifications** _____ **30**
 - 3.3. System configurations** _____ **33**
 - 3.4. Service conditions** _____ **35**
- 4. Plan a lifting operation** _____ **36**
 - 4.1. Ground bearing pressure calculation** _____ **37**
 - 4.2. Check the lifting capacity of the System** _____ **44**
 - 4.3. Side shift units and lifting lugs** _____ **48**
 - 4.4. The bearing capacity of the header beam** _____ **49**

4.5.	Side load	51
5.	<i>Install the System</i>	53
5.1.	How to hoist parts of the System	53
5.2.	Place the Skid Tracks	57
5.3.	Put the units upon the skid tracks	61
5.4.	Connect the power cables	62
5.5.	Put the boom in upright position	63
5.7.	Mount the header beams	66
5.8.	Put the side shifts on the header beams	68
5.9.	Mount the longitudinal beams	71
5.10.	Check the stroke sensor	71
5.11.	Install the remote control console (RCC)	72
5.12.	Perform an all-over visual inspection of the System	77
6.	<i>How to control the System</i>	78
6.1.	The Emergency buttons	78
6.2.	The Control Panel of the unit	79
6.3.	The remote control console (RCC)	81
7.	<i>Execute a lifting operation</i>	87
7.1.	Risks and Warnings	87
7.2.	Warning signs on the System	88
7.3.	Suspend the load	89
7.4.	Lift the load	90
7.5.	Move the load in longitudinal direction	92
7.7.	Move the load in transversal direction	94
7.8.	Tilt the load	95
8.	<i>Solve problems</i>	97
8.1.	Main problem localization procedure	97
8.2.	List of problems and solutions	98
9.	<i>Storage</i>	100
10.	<i>Maintenance</i>	101
10.1.	Mechanical	102
10.2.	Hydraulic	112
10.3.	Electrical	119
11.	<i>Quality</i>	120
12.	<i>Recycling the machine</i>	120
13.	<i>Index</i>	121
	<i>Appendices</i>	123

A. Checklist for planning a lifting operation	123
B. Checklist for installing the System	124
C. Final checks	126
D. Recording a lifting operation	128
E. Recording maintenance	130
F. Drawings for the skid tracks	133
G. Drawing of the units	135
H. Drawings of the side shift units	137
I. Drawings of the lifting lug	139
J. Hydraulic fluid safety information	140
K. Kroon Oil Multi purpose grease 3	144
L. Torque settings	150

1. Introduction

1.1. Manufacturer address

Enerpac Heavy Lifting Technology B.V
 Spinelstraat 15, 7554 TS
 Hengelo
 The Netherlands
 Tel. +31 74 242 20 45
 Fax. +31 74 243 03 38
 Email: info.hengelo@enerpac.com
 Website: www.enerpac.com

1.2. Declaration

Declaration of Conformity according to machine Directive 2006/42/EC.
 For the EC Declaration of Conformity reference is made to ref [6] "EC Declaration of conformity" which is part of the product delivery.

1.3. Referenced documents

Ref	Name	Identification	Manufacturer
1.	Operation of electrical installations - Low voltage	NEN 3140	NEN
2.	Operation of electrical installations	NEN-EN 50110-1	NEN
3.	General rules and safety requirements for systems and their components	NEN-EN-ISO 4413	NEN
4.	USB stick Wind calculations		Enerpac
5.	Technical handbook		Enerpac
6.	EC Declaration of conformity		Enerpac
7.	ASME B30.1-2015	Jacks, Industrial Rollers, Air Casters, and Hydraulic Gantries. <i>(Safety Standard for Cableways, Cranes, Derricks, Hoists, Hooks, Jacks and Slings)</i>	American Society of Mechanical Engineers

1.4. Identification

Each main component is fitted with a name plate as shown below.



The name plates are official documents. Altering or rendering them is illegible.

1.5. Liability

- Personnel as well as other people involved in the usage of the System are expected to have read and **understood** this manual.
- In cases of **doubt** about the use or application of this machine, always contact with Enerpac for advice and recommendations.
- **Unauthorised alterations** to the machine may have a deleterious effect on the characteristics of the machine and may disrupt the control functions. Unauthorised alterations therefore annul any resultant damage claims against the manufacturer.
- The **risk analysis** conducted by Enerpac, intended usage and reasonably foreseeable incorrect usage of the System were assessed. The instructions in this manual were drawn up based on this analysis.
- Unauthorised **modifications** to the machine may adversely affect its properties or disrupt normal functioning. Therefore, the manufacturer shall not be liable for any claims resulting from unauthorised modifications.

1.6. Intended use

The System is intended to move a load in vertical, longitudinal and transverse direction.

The definition of 'intended use' excludes any and all uses which do not meet the descriptions, including use that exceeds the machine's technical limitations. The manufacturer shall not accept any liability for damage resulting from use that is not in accordance with the machine's intended use. The user shall bear any and all risks. The definition of 'intended use' also includes strict compliance with the instructions in the user manual and assumes that the equipment is inspected and maintained at the indicated times.

- The System should only be used in the **intended manner** as described in the instructions in this manual, in particular listed in section 3.3. "System configurations".
- The System should only be operated by **operators** with full knowledge of the applicable safety regulations and the hazards which may arise during use.
- The System was developed and built according to the officially recognised safety **regulations**. However, if the machine is not used as intended:
 - This may pose a **risk** to the health and lives of operators and bystanders.
 - The System may not function properly or may create **hazardous** situations.
- The System should only be used if the machine is in perfect technical **condition**.
- Faults which may result in hazardous situations must be **resolved** immediately.
- The machine must not be used in potentially **explosive** environments.

1.7. Modifications

Never make any **modifications** or additions which could have an adverse impact on safety without prior approval from the manufacturer. This also applies to the installation and adjustment of safety devices and valves and welding work on the System.

Spare parts must always meet the technical specifications given by Enerpac in the construction file and the component construction lists for the machine. It is recommended to use original spare parts. In cases of doubt, please contact Enerpac.

1.8. Personnel and obligations

- Only **qualified personnel** are allowed to **operate** the System. Qualified personnel are those who have followed the official Gantry training of Enerpac and have obtained the Certificate.
- Only **qualified personnel** are allowed to **maintain** the System. Qualified personnel are those who have certified main education for the jobs they have perform, either mechanical, hydraulically or electrical.
- **Qualification** of the personnel is a responsibility of the customer.
- Always comply with legal **minimum age** stipulations.
- The System should only be used, maintained and repaired by properly **instructed** and **trained** personnel. Clearly describe the qualifications of the relevant employees with regard to use, commissioning, assembly, disassembly and all maintenance and repair work. If must be performed by third parties, they must receive clear instructions so both the client and the contractor are up-to-date on the agreements reached.
- The supervisor and operator are authorized to refrain from following any instructions from **third parties** that may pose a risk to the machines or bystanders.
- Personnel who have **not been fully trained** and instructed in the use of the machine, or personnel who have only received general training, may only perform work on the System under continuous **supervision** of a qualified person.
- Work on the **electrical** and the **hydraulics systems** must be performed by competent, qualified personnel, or by trained personnel under the direct supervision of qualified personnel, in compliance with all applicable rules and regulations.
- **Assembly and disassembly** may only be performed by trained installers under the supervision of an authorized person who has adequate knowledge of the System.

The responsibilities are conform the standard as referred to in Ref [7] ASME B30.1-2015

- In some situations, the owner and the user may be the same entity and is therefore accountable for all of the following responsibilities a listed in this chapter.
- In other cases, the user may lease or rent the system from the system without supervisory, operational, maintenance, support personnel, or services from the system owner. In these situations the following sections apply.

1.8.1. The owner of the system

The responsibilities of the owner of the system are:

- a) make sure the system meets the requirements as given in this manual as well as specific job requirements defined by the user.
- b) make sure the system and all necessary components, specified by the manufacturer, meet the user's requested configuration and capacity.
- c) providing the applicable capacity charts to the user.
- d) providing this manual to the user to enable correct assembly, disassembly, operation and maintenance information.
- e) make sure all inspections and maintenance activities are performed.
- f) designating personnel for maintenance, repair, transport, assembly, and disassembly.
- g) designating personnel for inspections as required in the applicable chapters.

1.8.2. The user of the system

The responsibilities of the user of the system are:

- a) complying with the requirements of this manual and all regulations applicable at the work site.
- b) using supervisors for activities
- c) ensure that the system is in proper operating condition, prior to initial use by
 - verifying that the Owner has provided this manual.
 - verifying that a frequent inspection has been performed.

- d) verifying that the system has the necessary capacity to perform the proposed operations in the planned configuration.
- e) ensuring the assigned operators have been notified of adjustments or repairs that have not yet been completed, prior to commencing operations.
- f) designating personnel for inspections as required in the applicable chapter.
- g) designating personnel for maintenance, repair, transport, assembly, and disassembly.
- h) ensuring that all personnel involved in maintenance, repair, transport, assembly, disassembly, and inspection are aware of their responsibilities, assigned duties, and the associated hazards.
- i) ensuring that the inspection, testing, and maintenance programs specified by owner are followed.

1.8.3. The site supervisor

In some cases the site supervisor and the system director may be the same person.

The responsibilities of the site supervisor shall include the following:

- a) ensuring that the system meets the requirements prior to initial site usage.
- b) determining if additional regulations or requirements are applicable.
- c) ensuring that a qualified person is designated as the system director.
- d) ensuring that the operations are coordinated with other jobsite activities that will be affected by or will affect the operations.
- e) ensuring that the area for the system is adequately prepared. The preparation includes, but is not limited to, the following:
 1. access for the system and associated equipment.
 2. sufficient room to assemble and disassemble the system.
 3. an operating area that is suitable for the system with respect to levelness, surface conditions, support capability, proximity to power lines, excavations, slopes, underground utilities, subsurface construction, and obstructions to operation.
 4. traffic control as necessary to restrict unauthorized access to the system's working area.
 5. ensuring that work involving the assembly and disassembly of system is supervised by a qualified person .
 6. ensuring that operators meet the physical, knowledge, and skill requirements as described in this manual.
 7. ensuring that conditions that may adversely affect the operations are addressed. Such conditions include, but are not limited to, the following:
 - poor soil or support conditions
 - wind velocity or gusting winds
 - weather conditions
 - extreme temperatures
 - inadequate lighting
 - operating surface conditions
 - excessive noise proximity to energized sources (e.g., power lines, pressurized lines)
 - ensuring that work performed by the rigging crew is supervised by a qualified person
 - ensuring that maintenance is performed by a designated person

1.8.4. The system director

The system Director's responsibilities shall include the following:

- a) being present at the job site during the operations.
- b) stopping the operations if alerted to an unsafe condition.
- c) ensuring that the preparation of the area needed to support the operation has been completed before the operation starts.
- d) ensuring necessary traffic controls are in place to restrict unauthorized access to the system's work area.

- e) ensuring that personnel involved in the operations understand their responsibilities, assigned duties, and the associated hazards.
- f) addressing safety concerns raised by the system operator or other personnel and being responsible if he decides to overrule those concerns and directs the operation to continue. In all cases the manufacturer's criteria for safe operation and the requirements of this manual shall be followed.
- g) designating the signal person(s) and conveying that information to the system operator.
- h) evaluating the operation in proximity to energized sources.
- i) ensuring precautions are implemented when hazards associated with special load handling operations are present. Such operations may include, but are not limited to, the following:
 - multiple types of system used simultaneously
 - shifting centre(s) of gravity or lifting below the centre of gravity
 - shifting, inclined, or moving surfaces
 - operating barges
- j) informing the system operator of the weight and planned movement of the loads to be handled.
- k) obtaining the system operator's verification that this weight does not exceed the system's rated load.
- l) ensuring that load rigging personnel have been designated for the system.
- m) ensuring that the load is properly rigged and stable.

1.8.5. The operators

The system Operator shall be responsible for the following listed items.

The system Operator shall not be responsible for hazards or conditions that are not under his direct control and that adversely affect the system operations.

Whenever the system Operator has doubt as to the safety of operation, the system Operator shall stop the system functions in a controlled manner. System operations shall resume only after safety concerns have been addressed and the continuation of the operation is directed by the system Director.



The system Operator's responsibilities shall include the following:



- a) reviewing the requirements for the system with the Director before the operations.
- b) knowing what types of site conditions could adversely affect the operation of the system and consulting with the system Director concerning the possible presence of those conditions.
- c) understanding and applying the information contained in this manual.
- d) understanding the system's functions and limitations as well as its particular operating characteristics.
- e) using the system's load/capacity chart(s) and diagrams and applying all notes and warnings related to the charts to confirm the correct system configuration to suit the load, site, and load handling conditions.
- f) refusing to operate the system when any portion of the load or the system could be adversely affected by proximity to energized sources until evaluated and approved by a qualified person.
- g) performing inspections as specified in the applicable chapter.
- h) promptly reporting the need for any adjustments or repairs.
- i) following applicable lock out/tag out procedures,
- j) not operating the system when physically or mentally unfit.
- k) ensuring that all controls are in the off or neutral position and that all personnel are in the clear before energizing the system.
- l) not engaging in any practice that will divert his attention while actually operating the system controls.
- m) testing the system function controls that will be used and operating the system only if those function controls respond properly.
- n) operating the system's functions, under normal operating conditions, in a smooth and controlled manner.

- o) knowing and following the procedures specified by the system manufacturer or approved by a qualified person for assembly, disassembly, and setting up the system.
- p) knowing how to travel the system, if applicable.
- q) ensuring that the load and rigging weight(s) have been provided.
- r) calculating or determining the rated load for all configurations that will be used and verifying, using the capacity chart(s), that the system has sufficient capacity for the proposed operation.
- s) considering all factors known that might affect the system capacity and informing the system Director of the need to make appropriate adjustments.
- t) knowing the standard and special signals as specified in the applicable chapter and responding to such signals from the signalperson. When a signalperson is not required, the system Operator is then responsible for the movement of the system. However, the system Operator shall obey a stop signal at all times, no matter who gives it.
- u) understanding bask load rigging procedures. For responsibility of rigging the load and ensuring that the load is rigged properly
- v) if power fails during the operations
 - set all locking devices
 - move all power controls to the OFF or neutral position
 - secure and stabilize the load, if practical
- w) before leaving the system unattended
 - secure and stabilize the load
 - set all locking devices
 - put the system controls in the OFF or neutral position
 - turn off the system power source
 - follow the recommendations as given in this manual or given by a qualified person for securing the system

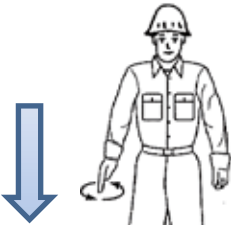
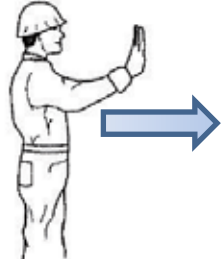
1.8.6. Hand signals

The following hand signals are applicable when using the system:

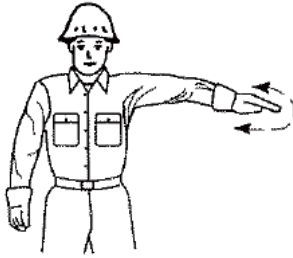
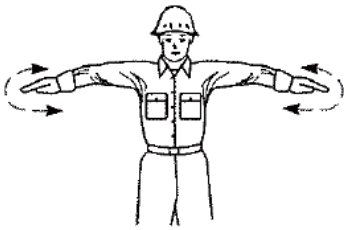
<p>RAISE.</p> <p>With forearm vertical, forefinger pointing up, move hand in small horizontal circle.</p>		<p>LOWER.</p> <p>With arm extended downward, forefinger pointing down, move hand in small horizontal circle.</p>	
<p>GANTRY TRAVEL.</p> <p>Arm extended forward, hand open and slightly raised, make pushing motion in direction of travel.</p>		<p>SIDE SHIFT.</p> <p>Palm up, fingers closed, thumb pointing in direction of motion, jerk hand horizontally.</p>	

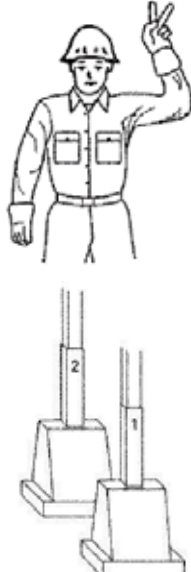
<p>STOP.</p> <p>Arm extended, palm down, move arm back and forth horizontally.</p>		<p>EMERGENCY STOP.</p> <p>Both arms extended, palms down, move arms back and forth horizontally.</p>	
<p>END EVERYTHING.</p> <p>Clasp hands in front of body.</p>		<p>INDIVIDUAL LEGS.</p> <p>Hold up: one finger for leg marked: "1," two fingers for leg marked "2".</p> <p>Regular signals follow.</p>	

1.9. Lifetime

No lifetime of the System is specified, since its safe and effective lifetime strongly depends on

- the intensity of the use,
- the quality of the maintenance,
- the service conditions in which the System is applied, like wet or salty environments,
- and the masses of the loads to which the System is exposed.

1.10. Warning symbols used within this document

This manual uses warnings and symbols to draw your attention to important safety information. The table below indicate the most common used labels in industrial documents.

**NB**

'NB' is used to highlight important **work activities** and for **additional information**

**Caution**

'Caution' is used if failure to heed the given instructions may result in **damage to the system**.

**Attention**

General warning to the operator of potential damage to **equipment** and the **environment**.

**Hazard**

Draws the user's attention to potential **hazards to personnel** if work instructions are not followed precisely.

2. General safety aspects

Subjects that must be followed are covered not only in this chapter; also in other chapters are specific safety directions that must be read and followed.

2.1. Mandatory protective gear

While using the System ensure that the applicable safety regulations are observed.

Make sure that all people on the working place observe the following safety regulations:



Always wear • safety goggles
and a safety helmet



Always wear • safety footwear



Wear safety gloves.
But we strongly advise not to wear them when
operating handheld control consoles



Wear a safety harness when working at heights
more than 2 meters

2.2. General safety regulations

Special safety regulations are given in the relevant national legislations or company regulations for accident prevention. Compliance with these rules and regulations is a legal requirement and a condition of employment. In addition to the safety regulations set out under the law, also observe the following points:

- Keep the worksite **clean**.
- Before every start-up, always check that there are no **persons** in an unsafe situation or position with respect to the System. Stop working if, despite warnings, there are still employees in an unsafe situation.
- Only use the System on an adequately stable and robust **subsurface**.
- Keep all equipment out of the area of above-ground **power lines**.
- The **coverings** must be closed (this does not apply to the covering on control panels).
- The operator must switch off the System before leaving it **unattended**.
- Use all required **Personal Protection Equipment (PPE)**.
- Do not wear any loose **clothing or jewelry**. Long hair must be tied back.
- **Tools** and equipment, necessary for (dis-)assembly of the System, as well as for maintenance has to be in good condition. Badly maintained equipment can cause time wastage and lead to permanent damage to the equipment and/or its surroundings.
- Keep the hydraulic and moving equipment of the System **clean** to prevent it from jamming or causing damage to itself or other equipment.
- Do not use the System, whether loaded or not, while unauthorized people are in its **vicinity**. The System can be operated remotely.
- Maintain **concentration** during the work. Carelessness may result in serious injuries.
- Additional **lifting gear** and accessories such as hawsers, shackles, lugs, slings etc. must comply with the legal requirements imposed in the country of use.
- **Inspect** the condition of the System before *every* individual start-up, given the fact that the slightest defect may have severe consequences.

Enerpac is not liable for improper use of accessories in combination with the System.

2.3. Symbols applied to the System

The System is labelled with

- warning symbols
- symbols with mandatory directions.

The table below show the most common used **warning symbols**.



Danger of contact with moving machine parts



Danger
Lethal voltage in the control panels



Danger of **parts of hands** getting trapped/caught



Danger of **parts of feet** getting trapped/caught



Danger of **falling**



Danger
Exercise extreme attention and caution when **under moving loads**.



Danger of getting **trapped**/caught between moving parts.

The table below shows the most commonly symbols with **mandatory directions** in industrial environments:



Read the instruction manual.



Wear **gloves** to prevent injury from and/or exposure to chemicals.



Wear safety **glasses** to prevent eye injuries.



Wear safety **shoes** to prevent injuries caused by falling objects and/or feet getting caught in machinery.



Wear **hearing** protection.



Wear a safety **helmet** to prevent injuries caused by falling objects.



Wear a safety **harness**



The stickers on the machine are **official documents** and it is not permitted to alter them or render them illegible.



It is **strictly obligatory** to observe the warning symbols and the mandatory symbols applied to the machine.

2.4. Welding work

- Welding, cutting and grinding work on the System is only permitted with the **prior written consent** of the manufacturer. Welders must be properly qualified and must have a valid welding certificate.
- If welding work needs to be performed on the System then
 - Switch the machine off
 - Disconnect all power cables and communications cables
 - Connect the system to a direct earth line.



Welding, cutting or grinding work on the System is not permitted without the manufacturer's prior written permission.

2.5. Working on the electrical system

- In the event of an electrical fault in the electric control system, you must bring all connected device into a safe condition. **Switch off** the System.
- Work on the electrical system must be performed by a competent, **qualified electrician** or by trained personnel under the direct supervision of a qualified electrician, in compliance with all applicable rules and regulations such as
 - Ref 1 "Operation of electrical installations - Low voltage"
 - Ref 2 "Operation of electrical installations"
- **Switch the power** off before inspection, maintenance or repair of the System. Make certain that the relevant parts are no longer receiving power. If necessary, connect the machine to earth. Insulate any adjacent components that are still receiving power.
- Check and inspect the electrical system of the System at **regular intervals**. Problems, such as loose connections and damaged or stuck wiring, must be resolved immediately. Only use original fuses and circuit breakers with the correct current value.
- If work does need to be performed on components receiving **power**, then cordon off the work zone and only use certified and properly insulated tools.

2.6. Working on the hydraulic system

- Work on the hydraulics system or other components in a pressurized system must be performed by a **competent, qualified installer** or by trained personnel under the direct supervision of a qualified installer, in compliance with all applicable rules and regulations.
- Check all pipes, hoses, quick-release couplings and screw joints **regularly** for leaks and visible external damage. Repair damage immediately. Pressurized hydraulic fluid leaks may cause serious injury, and it may cause fire and damage to the environment.
- If parts need to be removed from the hydraulic system, the **hydraulic pressure must be released** according to the instructions in this manual before beginning work.
- Expand and install pressurized hydraulic pipes, tubes and lines in accordance with professional standards.
- Make certain that no ports have been **switched**.

All parts and the length and quality of hoses meet the requirements of Ref 3 "General rules and safety requirements for systems and their components".

2.7. Fire

The course of action in the event of an emergency is determined by the rules and regulations applicable on the worksite. Every company has its own special rules. So make certain you are up-to-date on these rules.

In any case, the following actions are necessary in the event of a fire:

- Keep **calm**.
- **Report** the emergency to the employee responsible for in-house emergency services (IHES).
Tell who you are, where you are located and describe the emergency situation.
(The IHES employee will notify external emergency services.)
- **Warn** your colleagues.
- **Switch off** the electrical power supply.
- **Extinguish** the fire if it is still in its early stage, using the extinguishing means available onsite.
- **Leave the scene** of the emergency situation and report to the rendez-vous point.



Caution: Never use water to put out an electrical fire or a fluid fire.

2.8. Working with hazardous substances

It is thought that special first aid procedures are required in cases of accidents with chemicals. But in cases of small quantities, standard measures suffice:

- rinse thoroughly with water
- wash with soap
- provide fresh air
- remove any contaminated clothing

In common the following rules are applicable:

- Contact with the **skin**:
 - rinse thoroughly with water
 - remove any contaminated clothing
 - wash the relevant body parts with soap.
- Contact with the **eyes**:
 - rinse thoroughly with water (5 minutes) using eye wash fountain
 - consult a doctor.
- **Ingestion**:
 - rinse the mouth out with water.
 - If necessary, dilute the substance by drinking water.
 - If a corrosive substance has been ingested, do not induce vomiting. This is to prevent the substance coming into contact with the sensitive oesophagus again.
 - If the victim is unconscious, never attempt to induce vomiting or have the victim drink anything.

Using a 'neutralizing solution' (such as a base for an acid) can actually make the situation **worse**.

In addition to this, it is advisable to consult the safety information (TREM CARD book, safety information sheets and the catalogue) and report everything that is relevant to the accident to a doctor.

When work has to be done in confined spaces:

- Wear personal protection equipment
- ventilate according to the relevant regulations
- Ask a colleague to remain by the entrance in order to provide assistance in the event of an emergency.
- You are legally required to be **familiar with the potential hazards** of the product.
The safety information sheets are intended to provide adequate, correct and up-to-date information on all substances used on the worksite.
- Relevant safety information sheets are given in Appendix J Hydraulic fluid safety information of this manual.

During maintenance, you may work with substances fitted with **GHS symbols**. These GHS symbols are explained in the next below.¹

Symbol	General hazard indication	Possible precautionary measures
	May cause an allergic reaction on the skin.	Contaminated work clothing must not leave the workspace.
	Harmful to aquatic organisms, with long term effects	Do not discharge into the environment.
	Causes serious eye injury and/or damage to the skin.	Wear eye protection and skin protection (such as protective gloves).
	Fire hazard when heated and/or in presence of sparks.	Keep away from heat, sparks, open flames and/or hot surfaces. No smoking!
	May cause fire (oxidising agent).	Take the necessary precautionary measures to prevent mixture with flammable substances.
	Toxic in cases of ingestion and/or skin penetration	Do not eat, drink or smoke when using this product.
	May cause hypersensitivity of the airways or heritable mutations in male reproductive cells, is a potential carcinogen and/or is toxic to human reproduction	Apply a strict hygiene/health policy and wear suitable personal protection equipment.
	Explosion hazard when heated and/or in presence of sparks	Keep away from heat, sparks, open flames and/or hot surfaces. No smoking!
	Contains a gas under pressure. May explode if heated	Keep out of sunlight. Store in a well-ventilated space.

¹ CLP is the Regulation on Classification, Labelling and Packaging of substances and mixtures (EC No 1272/2008). This regulation brings European legislation on the classification, labelling and packaging of chemical substances into accordance with the GHS (Global Harmonised System for classification and labelling of chemical substances). The GHS is a United Nations system used to identify chemical substances and inform users of their hazards using standard symbols and phrases on labels, packaging and Safety Information Sheets (SIS).

2.9. Assembly and disassembly

- **Assembly** and disassembly of the System has to be performed by properly trained operators
- Only use **certified lifting** and hoisting equipment. Check the validity of these certificates and qualifications.
- Only use lifting and hoisting equipment with **suitable capacity** for the loads in question.
- Before commissioning, any parts that were disassembled for transport must be **re-assembled**, re-installed, checked and approved by personnel which is trained and qualified for the job. Use checklist B “Checklist for installing the System”.
- Make sure that the **instructions in this manual** have been followed precisely before commissioning the System.
- Lift loads as described in the user manual (connection points for lifting hooks) and observe the professional standards.



Caution: Any components that are blocked or stuck in any way (and any parts connected to these components) will be under mechanical tension. If you release these parts, they could change position suddenly and injure you (seriously).

2.10. Transport, loading and unloading of the System

- **Loading** and unloading has to be performed by properly trained operators
- Only use lifting and hoisting equipment with **suitable capacity** for the loads in question.
- **Lift loads** as described in the user manual (connection points for lifting hooks) and observe the professional standards.
- Only use **suitable containers** with adequate load-bearing capacity for transport purposes.
- **Secure** the load properly using suitable connection points and twist locks (for the containers). When using twist locks secure them properly and check that the locking mechanism is working correct.
- **Disconnect** all electrical and hydraulic connections when the System has to be moved, even if it is for only a short distance.
- To avoid damage during transport, **use timbers**, gummies and plastic packaging to prevent this.
- **Containers** may be used for transport, since they provide rigid protection against and avoid weather influences. Make sure that all parts are secured against sliding around.

3. System Overview

This chapter describes the main functions and components of the System.

3.1. General

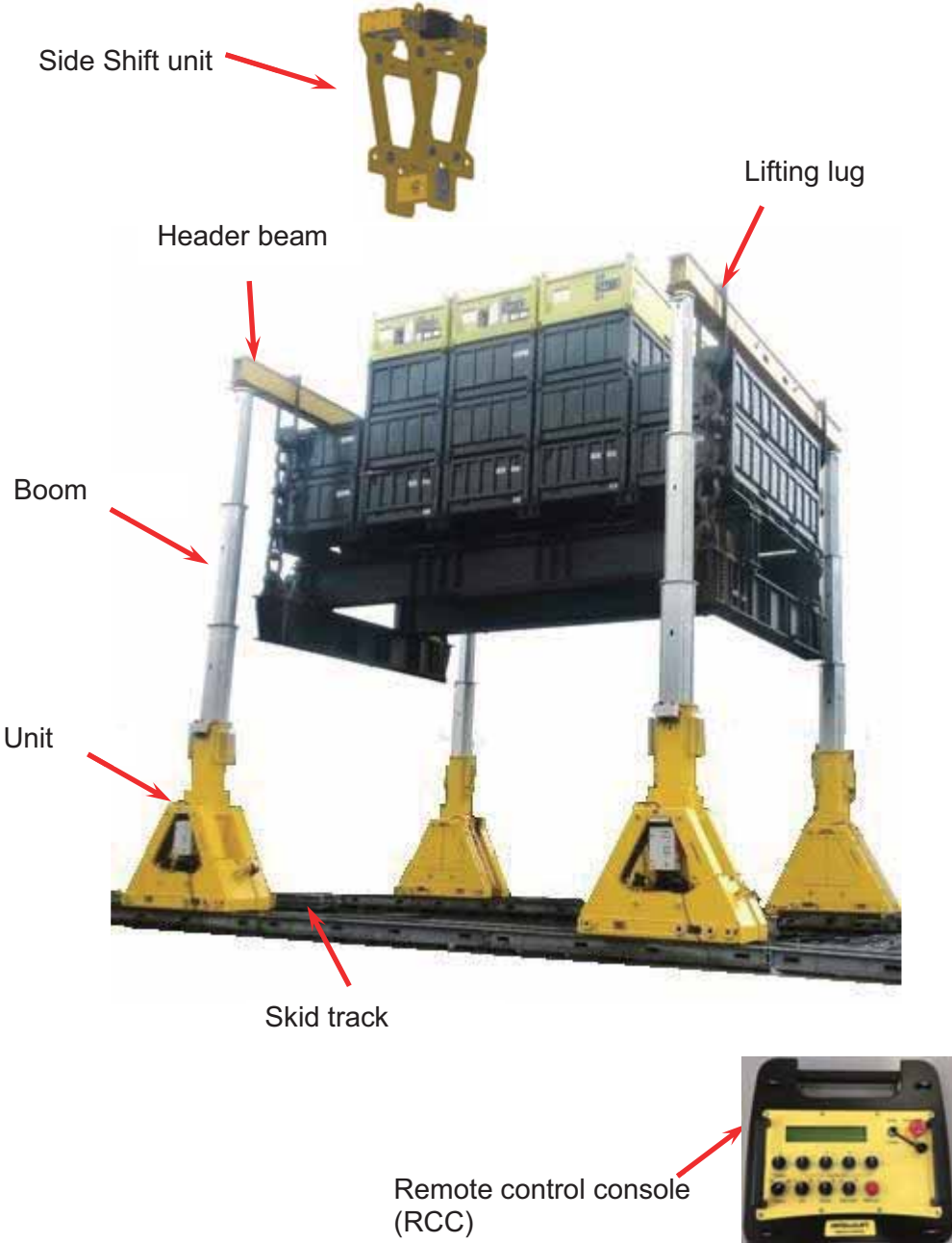

The System is a four point lifting system which can move a heavy load in three directions:

- Upwards by extending the booms
- In longitudinal direction by moving the units along the skid tracks
- In transversal direction by moving the side shift units (if applied) along the header beams



Some more properties:

- The System can put the boom in upright position hydraulically
- The System is provided with on-board hydraulic power. No hydraulic hoses have to be used on the working scene. Only connecting electric power is required.

3.1.1. The Unit

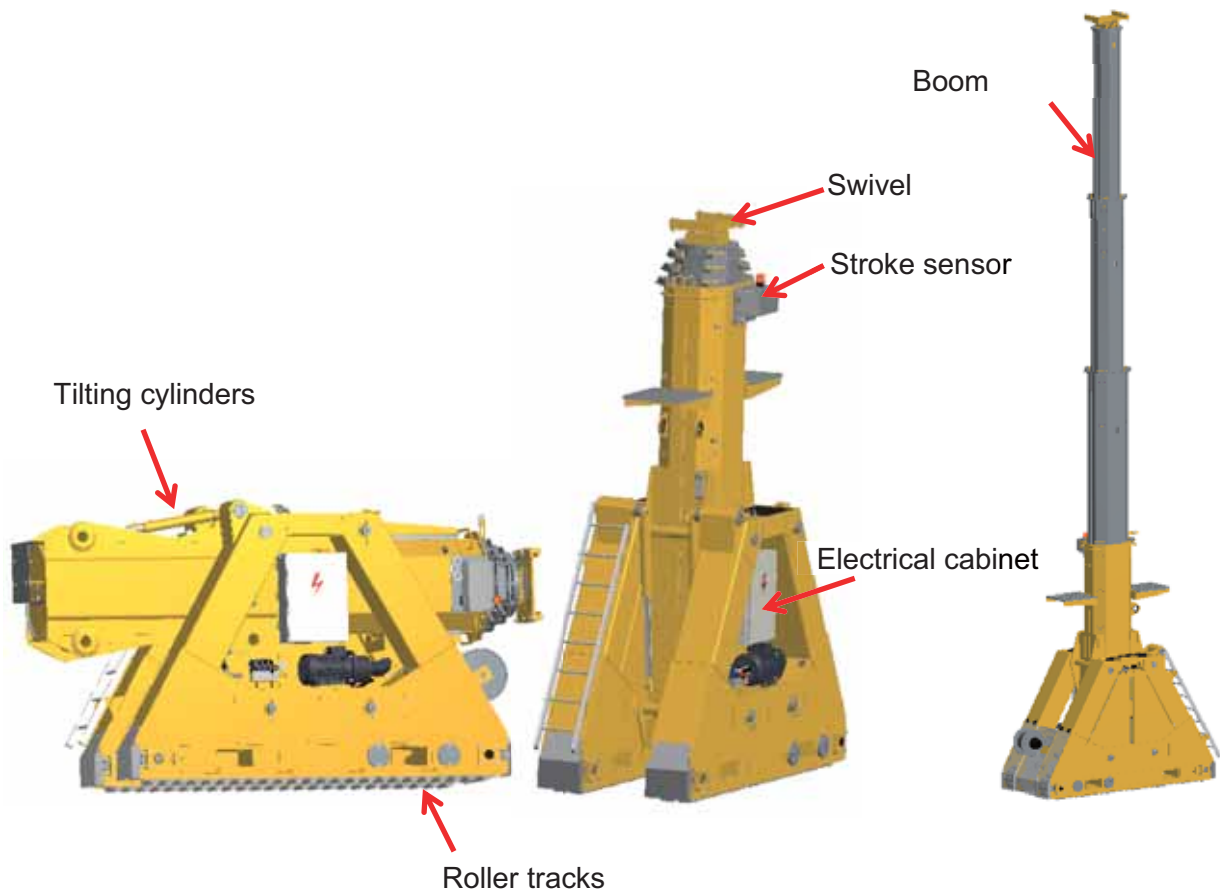

- The units can be controlled:
 - Individually, using the control panel on the electrical cabinets
 - Individually and simultaneously by the remote control console (RCC).
- The tilting cylinders can put the boom in upright position.
- In order to synchronize travelling of all units, each unit is provided with a travelling distance measuring device which runs on the skid track.

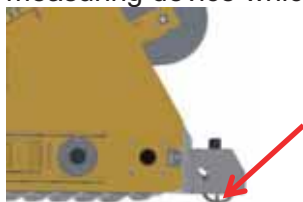

- The swivel enables flexible mounting of the header beam

- The boom consists of a telescopic cylinder system:
 - the SBL900 extends in two stages
 - the SBL1100 extends in three stages
- The boom is provided with guiding pads at the inner side, which
- centralise the stages of the boom
 - enable smooth moving of the stages into each other

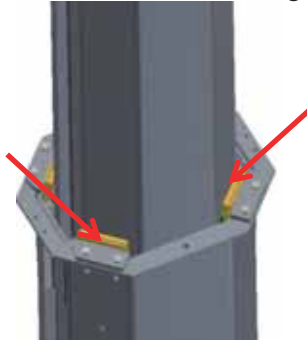

The guiding pads are adjustable in order to centralise the stages precisely. Since the guiding pads are made of plastic material, they are subject to wear.

- In order to synchronise the lifting heights of all units, each unit is provided with a stroke sensor. The sensor is provided with a wire which is attached to the top of the boom.

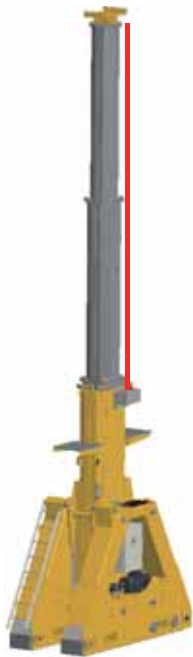

- Each unit is provided with a control panel which is used for local control of the unit itself (not of other units).



3.1.2. The Skid track

The skid tracks form a railway on which the System runs.

- Skid tracks spread the pressure on the ground.
- Skid tracks guide the units. Therefore, the skid tracks are provided with a ridge on top.



3.1.3. The Header beam

The header beams across the top of the units create a portal.

Two types of header beams can be applied:

- Integral header beams of various lengths



- Modular header beams composed out of more sections to construct various lengths.

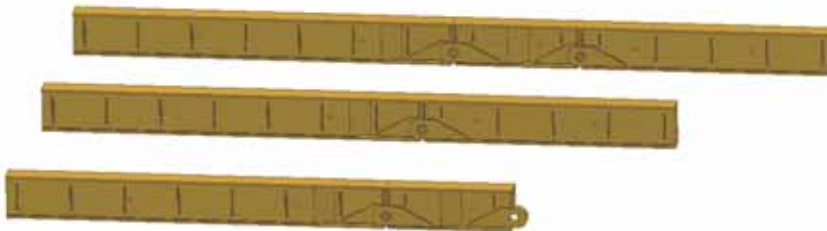

Header beams of foreign make may be applied if

- they have equal material properties
- their flange dimensions match with the Enerpac beams

3.1.4. The side shift units

The load can be affixed to the header beams by side shift units. Two types of side shift units can be applied:



HBS3000



HBS6000

- Side shift units enable moving of the load in transversal direction. Therefore, each side shift unit is provided with an electro motor which propels rollers. The rollers run on the header beams.
- Side shift units have only one single speed.
- Side shifts units can be controlled
 - by the RCC
 - by the control panel on the electrical cabinet.
- Optionally a transportation frame may be delivered for transporting and storage of the side shift unit:

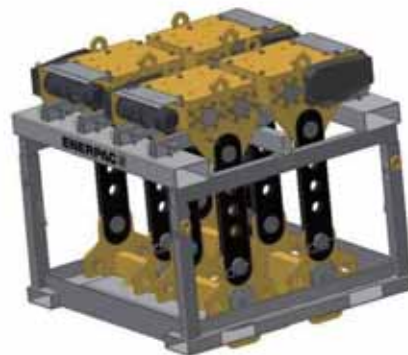

3.1.5. The Lifting lugs

The load can be affixed to the header beams by lifting lugs. Unlike side shift units, lugs cannot move the load aside.



Depending on the mass of the load to be lifted you can apply lifting lugs

- in double-plate configuration
- in single-plate configuration

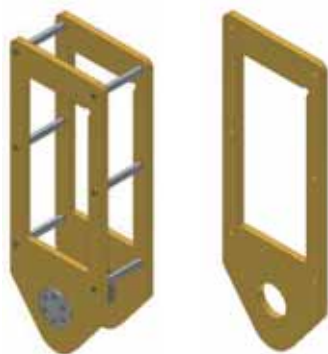

3.1.6. The Remote control console (RCC)

The RCC enables the operator

- to control the system on a safe distance
- to control all units simultaneously and synchronised



The RCC can be connected to the system

- by radio
- by wire

3.2. System specifications

3.2.1. Main specifications

The specifications listed below are valid both for the SL900 and the SL1100 system.

Specification of the power source	
Voltage	360 to 480 V AC/ 3-phase <i>The units feature automatic phase selection according to the rotation direction of the electric motors</i>
Current	16 A per unit
Frequency	50-60 Hz
Power	7.5 kW per unit
Fuse	32A
Plug	5 pins
Temperatures	
Minimum operating temperature of the machine	-10 °C <i>The battery of the RCC will only have half capacity</i>
Maximum operating temperature of the machine	50 °C
Minimum storage temperature of the machine	-25 °C
Maximum storage temperature of the machine	60 °C
Minimum storage temperature of the RCC	<ul style="list-style-type: none"> • 20 °C • 0 °C <i>While charging the battery</i>
Maximum storage temperature of the RCC	<ul style="list-style-type: none"> • 60 °C • 45 °C <i>While charging the battery</i>
Noise pressure	
<i>Measured at ear height at nominal loading one metre away from any Unit's electric motor (The C-weighted instantaneous sound pressure of 130 dB is never exceeded)</i>	77 dB (A)



Caution: There is a risk of ice accretion at temperatures below 0°C. If ice has accreted on machine components, they cannot be used because since they may lock up.

3.2.2. Operational specifications

Moving directions of the load				
Horizontally	Transverse direction		By moving the side shifts	
	Longitudinal direction		By moving the units along the skid tracks	
Vertically			By extending the booms	
Velocities of the units and the side shifts				
Unit	SBL900 / 1100	Travelling speed		18 meter/hour
		Extending time @ 40 Hz (during lifting a load)		Approx.60 minutes
		Retracting time @ 20 Hz (during lowering a load)		Approx.28 minutes
Side shift	HBS3000		90 cm / minute	
	HBS6000-Mk1		90 cm / minute	
Bearing capacities of units, side shifts, lifting lugs and beams				
Unit	SBL900	Stage 1	700 kN	5060 mm - 8372 mm
		Stage 2	500 kN	8372 mm - 11360 mm
	SBL1100	Stage 1	2621 kN	4409 mm - 7060 mm
		Stage 2	1689 kN	7060 mm - 9724 mm
		Stage 3	945 kN	9724 mm - 12016 mm
Side shift	HBS3000		750 kN	
	HBS6000-Mk1		1500 kN	
Lifting lug	LLSBL250	Single plate configuration		1250 kN
		Double plate configuration		2500 kN
Header beams		Header beams are optional parts. For bearing capacities reference is made to Ref 5 "Technical handbook".		

3.2.3. Dimensions

The following information of the main parts of the system is available in Appendixes:

- Dimensions
- Weights
- Technical drawings

Part	Appendix
Skid tracks	Appendix F "Drawings for the skid tracks"
Units	Appendix G "Drawing of the units"
Side shift	Appendix H "Drawings of the side shift unit"
Lifting lugs	Appendix I "Drawings of the lifting lug"

For technical details of the header beams reference is made to Ref 5 "Technical handbook".
The weights of the main parts of the system:

Type		Weight [kg]
Unit		11950 (incl oil)
Side shift unit	HBS3000	814 kg
	HBS6000 MK-1	1544 kg
Lifting lug	Double plate configuration	600 kg
	Single plate configuration	220 kg

3.3. System configurations

3.3.1. Header beam configurations

Header beams are optional parts. For technical information reference is made to Ref 5 "Technical handbook".

Proposed configurations of the System are:

- Classic configuration.
Two header beams, each of them connecting two units. **Lateral** stability is provided by the beams, and the Units contribute to the **longitudinal** stability.

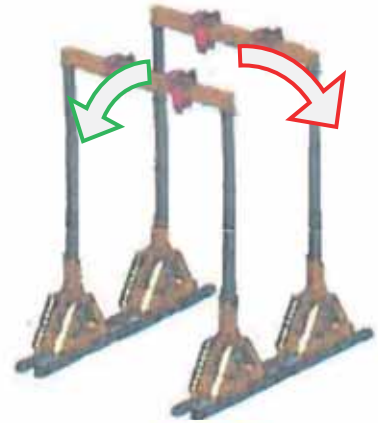

- Configuration with a single longitudinal header beam.:



- Configuration with double longitudinal header beams:







- If you want to use other configurations than the depicted make sure the correct calculations are made. Enerpac may advise.
- Enerpac cannot be held responsible for application of other configurations than the proposed.
- Configurations in which non-Enerpac equipment such as strand-jacks and skidding systems is applied, is allowed as long as all static requirements with reference to strength, deflections and stability are fulfilled.
- The use of non-Enerpac header beams is allowed as long as those are used in accordance with their own specifications.

3.3.2. Side shift units

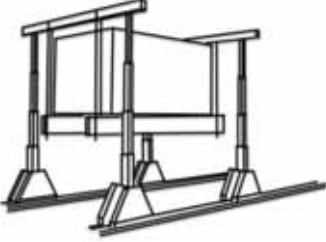
The side shift unit described in Appendix H “Drawings of the side shift unit” can be applied to both the SBL1100 and the SBL900 systems.

3.3.3. Position of the load

	<ul style="list-style-type: none"> • The System can lift loads while the load is suspended from the header beams.
	<ul style="list-style-type: none"> • The System can tilt a load.
	<ul style="list-style-type: none"> • If you want to put the load on top of the header beams, contact Enerpac.
	 <ul style="list-style-type: none"> • The system is exclusively suitable for lifting with four booms.



Call Enerpac for advice when you want to position the load differently.

3.4. Service conditions

- The System is intended for hoisting loads.
Do not use the System for any other purpose.
- No alterations may be made to the System.
Only use the System as it was delivered.



The System is explicitly **not intended** for transporting people.



Attention: Lifting operations with **less than four units** is **strictly prohibited**



Hazard: Lifting a load **with only two units** is a high risk operation, hazardous and therefore prohibited:

The System with its load can tip-over completely, due to

- out of centre of gravity
- swinging of the load
- large sling angles.

Such an operation may lead to an accident which causes damage to the

- machine itself
- objects and goods in its vicinity or mounted to the machine

People in the immediate area may get severely injured.

4. Plan a lifting operation

In this chapter, the planning activities for a lifting operation are described.

1. Record your planning activities in the checklist given in Appendix A “Checklist for planning a lifting operation”.
2. Make sure the following information is available:
 - Mass of the load
 - Centre of gravity of the load
 - Dimensions of the load
 - Allowable ground bearing pressure
3. Determine the lifting height
4. Consider the following subjects:
 - Lifting capacity of the most heavily loaded unit
 - Lifting capacity of the side shift
 - Lifting capacity of the header beams
 - Bearing capacity of the ground
Is additional foundation underneath the skid tracks necessary?
 - The wind load



It is of the utmost importance to perform all steps described in this section carefully, before starting the lifting operation.



Hazard : Failure to prepare a lifting operation correctly may result in loss of System stability during use.

4.1. Ground bearing pressure calculation

Skid tracks can be put

- directly on the ground , if the bearing capacity of the ground is sufficient.
- on a foundation:
 - to compensate unevenness in the ground
 - to reduce the bearing pressure. Use is made of the effect that pressure spreads down in an angle of 45° , as shown below. So the higher the foundation, the lower the ground bearing pressure.

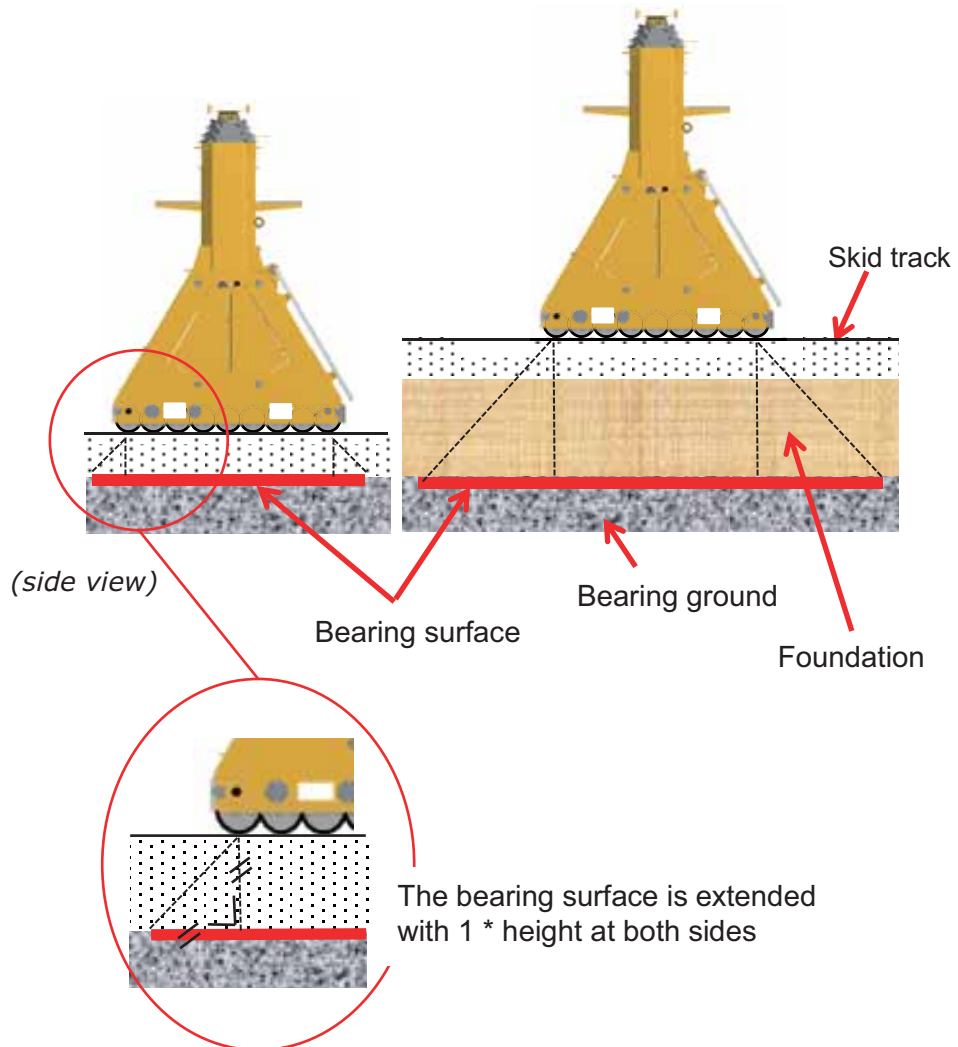

The following sections describe how the bearing pressure can be calculated. Feel free to apply your own calculation methods.



The pressure on the ground is inverse proportional with the height of the supporting material.

4.1.1. No foundation applied

The dimensions of the bearing surface are as follows:

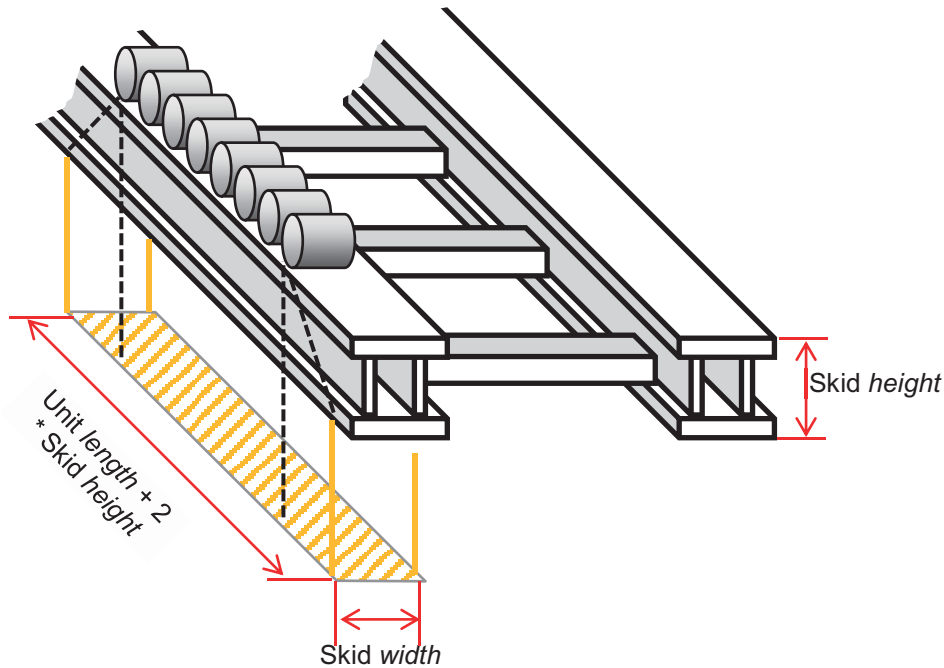

To calculate the bearing pressure, you *may* use the following procedure:

Parameter	Abbrev	Value
Unit	Length	<i>Unit length</i> 2.76 m
	Own mass	<i>Unit mass</i> 12 metric tons
Skid track	Height	<i>Skid height</i> 0.3 m
	Width	<i>Skid width</i> 0.3 m
Auxiliary material (beams, shackles etc)	<i>Aux mass</i>	20 metric tons
Safety factor	S	1.7
Maximum force on one unit which can occur during the operation	F	t.b.s.

1.	Bearing surface, including the spreading effect in length direction, of one unit	<p>Bearing_surface = $2 \text{ tracks} * [(Unit \ length + 2 * Skid \ height) * Skid \ width]$</p>
2.	Pressure on the ground [metric tonnes / m ²]	$\sigma = \frac{F / 4 + Unit_mass + Aux_mass / 4}{Bearing_surface} * S$

Example:

Load to be lifted

1068 metric tons

Ground pressure

$$\sigma = \frac{1068 / 4 + 12 + 20 / 4}{2.0} * 1.7 = \mathbf{241} \text{ metric tons / m}^2$$



Complete the checklist in appendix A “Checklist for planning a lifting operation” with the calculated bearing pressure.



Attention: the exerted ground pressure may never exceed the maximum allowed ground bearing pressure.

4.1.2. Foundation applied

Timbers of Azobé hard wood can be used as foundation material. Steel plates have to be mounted between the timbers and the skid tracks.

The dimensions of the bearing surface are determined as follows:

- The width of one footprint:

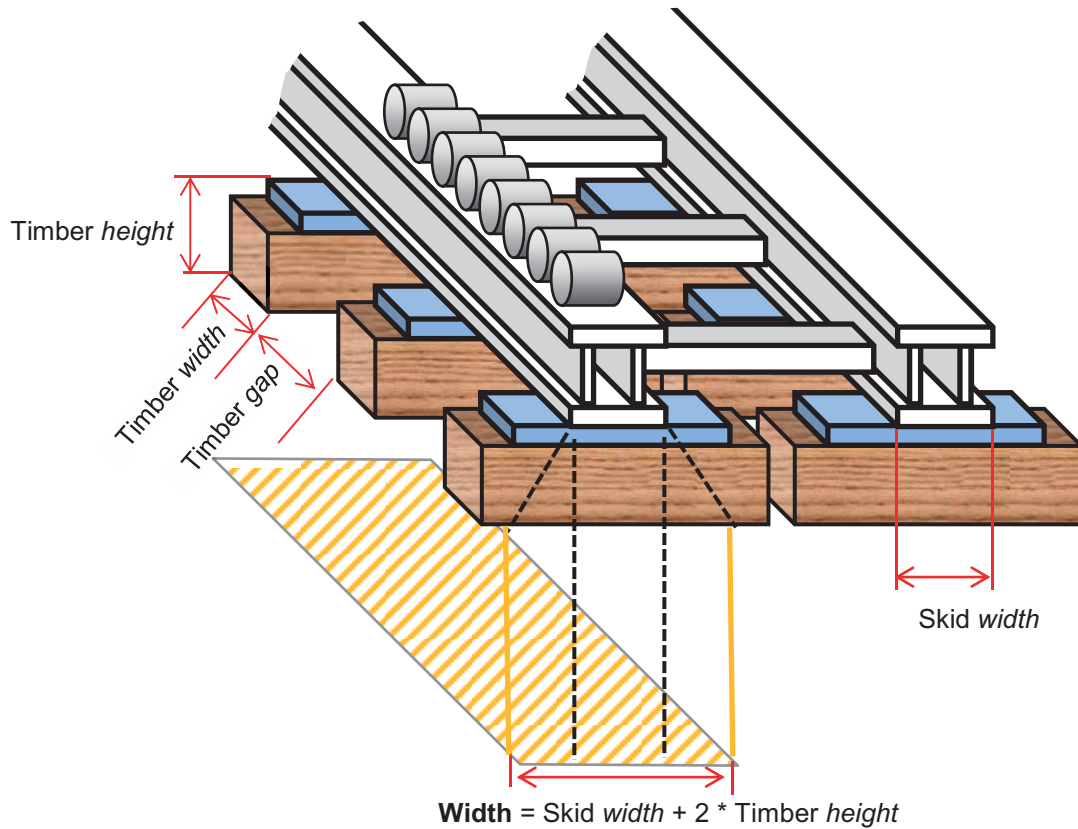

- The length of one footprint:

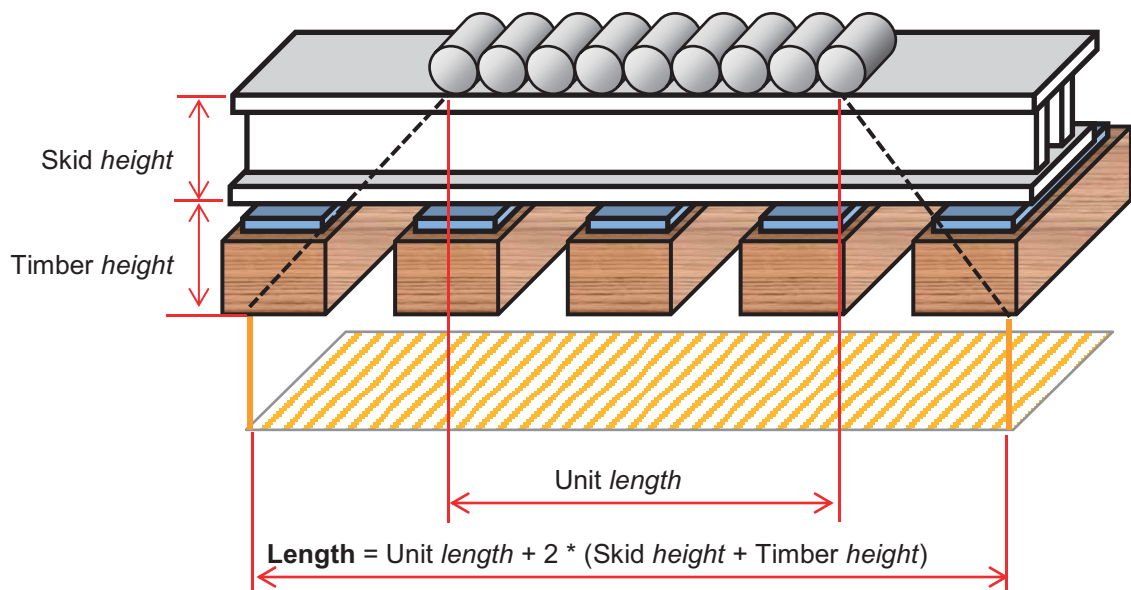

To calculate the bearing pressure, you *may* use the following procedure:

Parameter		Abbrev	Value
Unit	Length	Unit <i>length</i>	2.76 m
	Own mass	Unit <i>mass</i>	12 metric tons
Skid track	Height	Skid <i>height</i>	0.3 m
	Width	Skid <i>width</i>	0.3 m
Auxiliary material (beams, shackles etc)		Aux <i>mass</i>	20 metric tons
Safety factor		S	1.7
Maximum force on one unit which can occur during the operation		F	Depends on the operation
Timbers	Width	Timber <i>width</i>	Depend on the applied timbers
	Height	Timber <i>height</i>	
	Gap between the timbers	Timber <i>gap</i>	

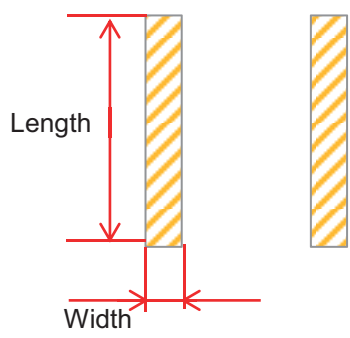
1.	Surface of one footprint = width * length	$(Skid\ width + 2 * Timber\ height) * [Unit\ length + 2 * (Skid\ height + Timber\ height)]$
2.	Surface on which the pressure is exerted for one unit = 2 * footprint	<p>2 * footprint</p> 
3.	Support ratio, to correct for the gaps between the timbers	<p>Support_Ratio =</p> $Timber\ width / (Timber\ width + Timber\ gap)$
4.	Pressure on the ground [metric tonnes / m ²]	$\sigma = \frac{F + Unit_mass + Aux_mass / 4}{Surface * SupportRatio} * S$

Example:

Load to be lifted		1068 metric tons
Timbers:	Width	0.10 m
	Height	0.10 m
	Gap	0.03 m

Measure of one footprint:

Width: $\text{Skid width} + 2 * \text{Timber height} = 0.3 + 2 * 0.1 = 0.5$

Length: $\text{Unit length} + 2 * (\text{Skid height} + \text{Timber height}) = 2.76 + 2 * (0.3 + 0.1) = 3.56 \text{ m}$

L * W: $0.5 * 3.56 = 1.78 \text{ m}^2$

Two footprints: $2 * 1.78 = 3.56 \text{ m}^2$

Support ratio: $0.10 / (0.10 + 0.03) = 0.77$

Ground pressure $\sigma = \frac{1068 / 4 + 12 + 20 / 4}{3.56 * 0.77} * 1.7 = \mathbf{176} \text{ metric tons /m}^2$



Complete the checklist in appendix A “Checklist for planning a lifting operation” with the calculated bearing pressure.



Attention: the exerted ground pressure may never exceed the bearing capacity of the ground.

4.1.3. Requirements for foundation material

The foundation material has to meet the following requirements:

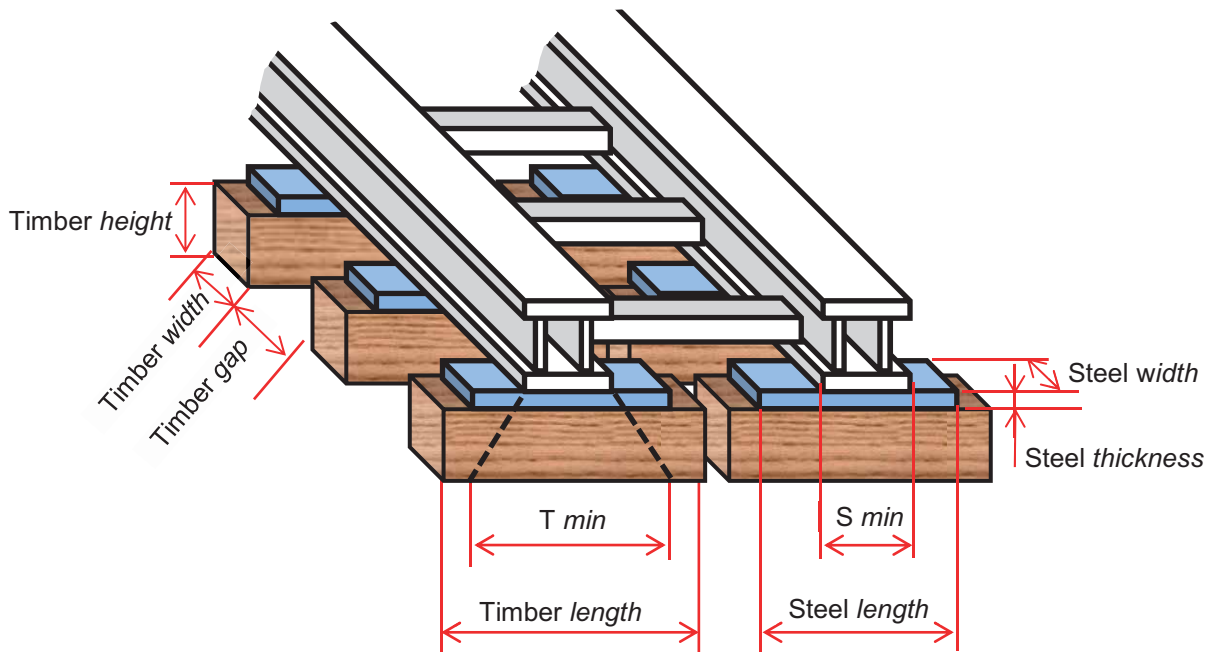

Parameter		Requirement
Timbers	Timber length	> T_{min} < 612mm
	Timber width	> Timber height
	Timber gap	< Timber width
	mechanical compressive strength	> 25 N/mm ² without occurrence of deflection  Enerpac strongly recommends adhering to 30N/mm ² , preferably Azobé wood
Steel plates	Steel length	> S_{min}
	Steel width	= Timber width
	Steel thickness	> 15 mm
	mechanical compressive strength	> 30 N/mm ² without occurrence of deflection
	Mounting	properly secured



- Wood is a natural product: its quality is not assured. In order to guarantee quality, test the timbers on 125% of the expected load.
- For your planning keep in mind that suitable wood may not always be available immediately.



Hazard: Use of other wood types such as plywood, multiply, pine and compressed wood is **explicitly prohibited**.

4.2. Check the lifting capacity of the System

The capacities and dimensions of the units, the side shifts, and skid tracks are given in section 3.2.2 “Operational specifications”. Use this information to determine the feasibility of your lifting operation.



Caution: though all limits for the capacity, lifting height, skew and environmental influences are either calculated or tested by the Enerpac consciously, during lifting operations these parameters may interfere with each other in a negative way. Test situations differ from real life situations!

4.2.1. Maximum load

The bearing capacity of the System depends on the degree of extension of the beams: the more extension, the less bearing capacity will be.



Stage 1
SBL900,
SBL1100

Stage 2
SBL900,
SBL1100

Stage 3
SBL1100

Complete the checklist in Appendix A “Checklist for planning a lifting operation”, under “Stage of Extension”.

The maximum load per Unit

The bearing capacity per Stage is given in the table of section 3.2.2 “Operational specifications” on page 31.



The capacity of a System is four times the maximum load on one unit.

The effect of eccentricity of the Centre of Gravity on the capacity of the System

When the Centre of Gravity (COG) is not in the centre of the System, the capacity of the System will decrease. The figures below give the principle of it. The numbers are fictitious.

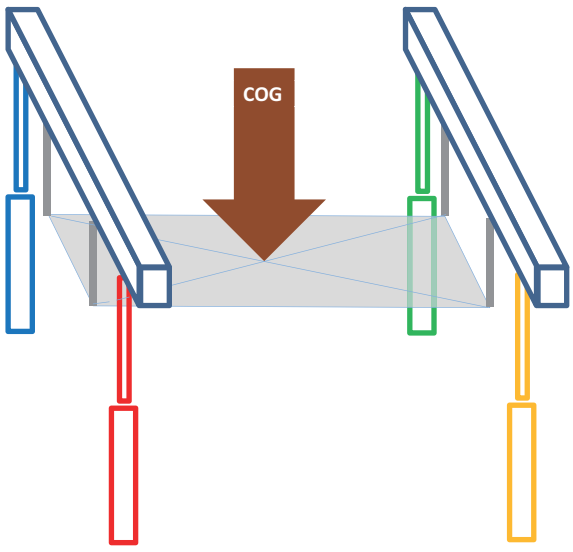
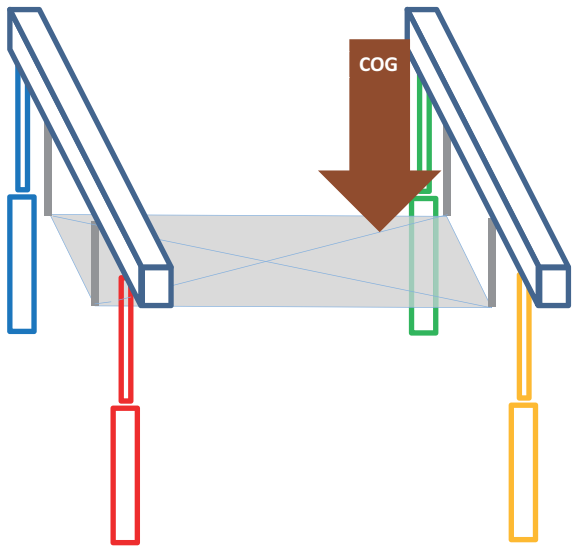
Assume: <ul style="list-style-type: none"> • a load of 1000 kN • a bearing capacity per unit of 250 kN • stage 2 used 	
Centre of Gravity in the centre	Centre of Gravity eccentric
	
The load is spread equally over the units: All Units bear $1000 / 4 = 250$ kN	The load is spread unequally over the units. The load on the 'green unit has increased significantly and exceeds 250 kN
The system is loaded to its limits, but none of the units is overloaded.	The green unit is overloaded! The system cannot lift the 1000 kN anymore but less, to prevent overload in the green unit. <i>The capacity of the system has decreased due to eccentricity of the load.</i>



The more the COG of the load deviates from the centre of the System, the less the capacity will be.

The capacity charts on the next pages show the bearing capacity of the system in relation to the position of the load. The **coloured** cells in that **capacity chart** correspond with the **units** in the figure above.

Use the capacity chart as follows for your **side shift operations**:

- Locate the position of the COG in the capacity chart, as shown at the right →
- The data on that spot shows the total capacity (4 units) of the system.

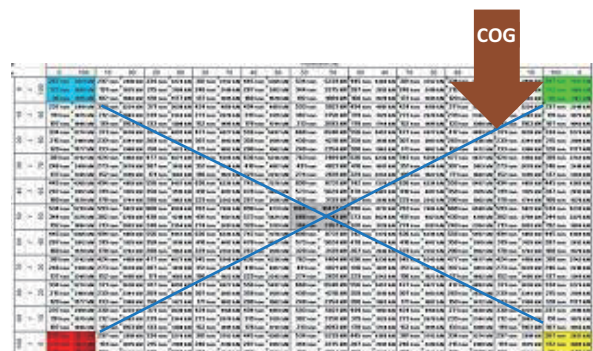

Capacity chart of SBL1100 (metric version) ED.03622.70.001.R00.ENG

Max load per unit			Stage 1:	267	Te																					
			Stage 2:	172	Te																					
			Stage 3:	96	Te																					
1 st stage	Position of COG in relation to distance between lifting units																									
2 nd stage	Y-direction [%]																									
3 rd stage		0	100	10	90	20	80	30	70	40	60	50	50	60	40	70	30	80	20	90	10	100	0			
Position of COG in relation to distance between lifting units	X-direction [%]	0	/	267 ton 2619 kN 172 ton 1687 kN 96 ton 942 kN	297 ton 2910 kN 191 ton 1875 kN 107 ton 1046 kN	2910 kN 1875 kN 1046 kN	3274 kN 2109 kN 1177 kN	3742 kN 2410 kN 1495 kN	4365 kN 2812 kN 1570 kN	5239 kN 3375 kN 1884 kN	4365 kN 2812 kN 1570 kN	534 ton 5239 kN 344 ton 3375 kN 192 ton 1884 kN	4365 kN 2812 kN 1570 kN	534 ton 5239 kN 344 ton 3375 kN 192 ton 1884 kN	4365 kN 2812 kN 1570 kN	534 ton 5239 kN 344 ton 3375 kN 192 ton 1884 kN	4365 kN 2812 kN 1570 kN	534 ton 5239 kN 344 ton 3375 kN 192 ton 1884 kN	4365 kN 2812 kN 1570 kN	534 ton 5239 kN 344 ton 3375 kN 192 ton 1884 kN	4365 kN 2812 kN 1570 kN	534 ton 5239 kN 344 ton 3375 kN 192 ton 1884 kN	4365 kN 2812 kN 1570 kN	534 ton 5239 kN 344 ton 3375 kN 192 ton 1884 kN		
			10	297 ton 2910 kN 191 ton 1875 kN 107 ton 1046 kN	330 ton 3234 kN 212 ton 2083 kN 119 ton 1163 kN	3234 kN 2083 kN 1163 kN	3638 kN 2344 kN 1308 kN	4158 kN 2678 kN 1495 kN	4851 kN 3125 kN 1744 kN	5821 kN 3750 kN 2093 kN	4851 kN 3125 kN 1744 kN	5821 kN 3750 kN 2093 kN	4851 kN 3125 kN 1744 kN	593 ton 5821 kN 382 ton 3750 kN 213 ton 2093 kN	4851 kN 3125 kN 1744 kN	593 ton 5821 kN 382 ton 3750 kN 213 ton 2093 kN	4851 kN 3125 kN 1744 kN	593 ton 5821 kN 382 ton 3750 kN 213 ton 2093 kN	4851 kN 3125 kN 1744 kN	593 ton 5821 kN 382 ton 3750 kN 213 ton 2093 kN	4851 kN 3125 kN 1744 kN	593 ton 5821 kN 382 ton 3750 kN 213 ton 2093 kN	4851 kN 3125 kN 1744 kN	593 ton 5821 kN 382 ton 3750 kN 213 ton 2093 kN		
			20	334 ton 3274 kN 215 ton 2109 kN 120 ton 1177 kN	371 ton 3638 kN 239 ton 2344 kN 133 ton 1308 kN	3638 kN 2344 kN 1308 kN	4093 kN 2636 kN 1472 kN	4677 kN 3013 kN 1682 kN	5457 kN 3515 kN 1962 kN	6548 kN 4300 kN 2354 kN	5457 kN 3515 kN 1962 kN	6548 kN 4300 kN 2354 kN	5457 kN 3515 kN 1962 kN	668 ton 6548 kN 430 ton 4218 kN 240 ton 2354 kN	5457 kN 3515 kN 1962 kN	668 ton 6548 kN 430 ton 4218 kN 240 ton 2354 kN	5457 kN 3515 kN 1962 kN	668 ton 6548 kN 430 ton 4218 kN 240 ton 2354 kN	5457 kN 3515 kN 1962 kN	668 ton 6548 kN 430 ton 4218 kN 240 ton 2354 kN	5457 kN 3515 kN 1962 kN	668 ton 6548 kN 430 ton 4218 kN 240 ton 2354 kN	5457 kN 3515 kN 1962 kN	668 ton 6548 kN 430 ton 4218 kN 240 ton 2354 kN		
		30	/	381 ton 3742 kN 246 ton 2410 kN 137 ton 1345 kN	424 ton 4158 kN 273 ton 2678 kN 152 ton 1495 kN	4158 kN 2678 kN 1495 kN	4677 kN 3013 kN 1682 kN	5345 kN 3444 kN 2242 kN	6236 kN 4100 kN 2292 kN	5345 kN 3444 kN 2242 kN	6236 kN 4100 kN 2292 kN	5345 kN 3444 kN 2242 kN	6236 kN 4100 kN 2292 kN	763 ton 7484 kN 491 ton 4821 kN 274 ton 2691 kN	5345 kN 3444 kN 2242 kN	763 ton 7484 kN 491 ton 4821 kN 274 ton 2691 kN	5345 kN 3444 kN 2242 kN	763 ton 7484 kN 491 ton 4821 kN 274 ton 2691 kN	5345 kN 3444 kN 2242 kN	763 ton 7484 kN 491 ton 4821 kN 274 ton 2691 kN	5345 kN 3444 kN 2242 kN	763 ton 7484 kN 491 ton 4821 kN 274 ton 2691 kN	5345 kN 3444 kN 2242 kN	763 ton 7484 kN 491 ton 4821 kN 274 ton 2691 kN		
			40	445 ton 4365 kN 287 ton 2812 kN 160 ton 1570 kN	494 ton 4851 kN 319 ton 3125 kN 178 ton 1744 kN	4851 kN 3125 kN 1744 kN	5457 kN 3515 kN 1962 kN	6236 kN 4100 kN 2616 kN	7276 kN 4687 kN 2616 kN	8731 kN 5730 kN 3139 kN	6236 kN 4100 kN 2616 kN	7276 kN 4687 kN 2616 kN	8731 kN 5730 kN 3139 kN	890 ton 8731 kN 573 ton 5624 kN 320 ton 3139 kN	6236 kN 4100 kN 2616 kN	890 ton 8731 kN 573 ton 5624 kN 320 ton 3139 kN	6236 kN 4100 kN 2616 kN	890 ton 8731 kN 573 ton 5624 kN 320 ton 3139 kN	6236 kN 4100 kN 2616 kN	890 ton 8731 kN 573 ton 5624 kN 320 ton 3139 kN	6236 kN 4100 kN 2616 kN	890 ton 8731 kN 573 ton 5624 kN 320 ton 3139 kN	6236 kN 4100 kN 2616 kN	890 ton 8731 kN 573 ton 5624 kN 320 ton 3139 kN		
	50	/	534 ton 5239 kN 344 ton 3375 kN 192 ton 1884 kN	593 ton 5821 kN 382 ton 3750 kN 213 ton 2093 kN	5821 kN 3750 kN 2093 kN	6548 kN 4300 kN 2354 kN	7484 kN 4821 kN 2691 kN	8731 kN 5624 kN 3139 kN	6548 kN 4300 kN 2354 kN	7484 kN 4821 kN 2691 kN	8731 kN 5624 kN 3139 kN	8731 kN 5624 kN 3139 kN	1068 ton 10477 kN 688 ton 6749 kN 384 ton 3767 kN	8731 kN 5624 kN 3139 kN	1068 ton 10477 kN 688 ton 6749 kN 384 ton 3767 kN	8731 kN 5624 kN 3139 kN	1068 ton 10477 kN 688 ton 6749 kN 384 ton 3767 kN	8731 kN 5624 kN 3139 kN	1068 ton 10477 kN 688 ton 6749 kN 384 ton 3767 kN	8731 kN 5624 kN 3139 kN	1068 ton 10477 kN 688 ton 6749 kN 384 ton 3767 kN	8731 kN 5624 kN 3139 kN	1068 ton 10477 kN 688 ton 6749 kN 384 ton 3767 kN			
		60	445 ton 4365 kN 287 ton 2812 kN 160 ton 1570 kN	494 ton 4851 kN 319 ton 3125 kN 178 ton 1744 kN	4851 kN 3125 kN 1744 kN	5457 kN 3515 kN 1962 kN	6236 kN 4100 kN 2616 kN	7276 kN 4687 kN 2616 kN	8731 kN 5730 kN 3139 kN	6236 kN 4100 kN 2616 kN	7276 kN 4687 kN 2616 kN	8731 kN 5730 kN 3139 kN	890 ton 8731 kN 573 ton 5624 kN 320 ton 3139 kN	6236 kN 4100 kN 2616 kN	890 ton 8731 kN 573 ton 5624 kN 320 ton 3139 kN	6236 kN 4100 kN 2616 kN	890 ton 8731 kN 573 ton 5624 kN 320 ton 3139 kN	6236 kN 4100 kN 2616 kN	890 ton 8731 kN 573 ton 5624 kN 320 ton 3139 kN	6236 kN 4100 kN 2616 kN	890 ton 8731 kN 573 ton 5624 kN 320 ton 3139 kN	6236 kN 4100 kN 2616 kN	890 ton 8731 kN 573 ton 5624 kN 320 ton 3139 kN			
		70	381 ton 3742 kN 246 ton 2410 kN 137 ton 1345 kN	424 ton 4158 kN 273 ton 2678 kN 152 ton 1495 kN	4158 kN 2678 kN 1495 kN	4677 kN 3013 kN 1682 kN	5345 kN 3444 kN 2242 kN	6236 kN 4100 kN 2242 kN	7484 kN 4821 kN 2691 kN	5345 kN 3444 kN 2242 kN	6236 kN 4100 kN 2242 kN	7484 kN 4821 kN 2691 kN	763 ton 7484 kN 491 ton 4821 kN 274 ton 2691 kN	6236 kN 4100 kN 2242 kN	763 ton 7484 kN 491 ton 4821 kN 274 ton 2691 kN	6236 kN 4100 kN 2242 kN	763 ton 7484 kN 491 ton 4821 kN 274 ton 2691 kN	6236 kN 4100 kN 2242 kN	763 ton 7484 kN 491 ton 4821 kN 274 ton 2691 kN	6236 kN 4100 kN 2242 kN	763 ton 7484 kN 491 ton 4821 kN 274 ton 2691 kN	6236 kN 4100 kN 2242 kN	763 ton 7484 kN 491 ton 4821 kN 274 ton 2691 kN			
		80	/	334 ton 3274 kN 215 ton 2109 kN 120 ton 1177 kN	371 ton 3638 kN 239 ton 2344 kN 133 ton 1308 kN	3638 kN 2344 kN 1308 kN	4093 kN 2636 kN 1472 kN	4677 kN 3013 kN 1682 kN	5457 kN 3515 kN 1962 kN	6548 kN 4300 kN 2354 kN	4677 kN 3013 kN 1682 kN	5457 kN 3515 kN 1962 kN	668 ton 6548 kN 430 ton 4218 kN 240 ton 2354 kN	4677 kN 3013 kN 1682 kN	668 ton 6548 kN 430 ton 4218 kN 240 ton 2354 kN	4677 kN 3013 kN 1682 kN	668 ton 6548 kN 430 ton 4218 kN 240 ton 2354 kN	4677 kN 3013 kN 1682 kN	668 ton 6548 kN 430 ton 4218 kN 240 ton 2354 kN	4677 kN 3013 kN 1682 kN	668 ton 6548 kN 430 ton 4218 kN 240 ton 2354 kN	4677 kN 3013 kN 1682 kN	668 ton 6548 kN 430 ton 4218 kN 240 ton 2354 kN			
			90	297 ton 2910 kN 191 ton 1875 kN 107 ton 1046 kN	330 ton 3234 kN 212 ton 2083 kN 119 ton 1163 kN	3234 kN 2083 kN 1163 kN	3638 kN 2344 kN 1308 kN	4158 kN 2678 kN 1495 kN	4851 kN 3125 kN 1744 kN	5821 kN 3750 kN 2093 kN	3638 kN 2344 kN 1308 kN	4158 kN 2678 kN 1495 kN	4851 kN 3125 kN 1744 kN	593 ton 5821 kN 382 ton 3750 kN 213 ton 2093 kN	3638 kN 2344 kN 1308 kN	593 ton 5821 kN 382 ton 3750 kN 213 ton 2093 kN	3638 kN 2344 kN 1308 kN	593 ton 5821 kN 382 ton 3750 kN 213 ton 2093 kN	3638 kN 2344 kN 1308 kN	593 ton 5821 kN 382 ton 3750 kN 213 ton 2093 kN	3638 kN 2344 kN 1308 kN	593 ton 5821 kN 382 ton 3750 kN 213 ton 2093 kN				
	100	267 ton 2619 kN 172 ton 1687 kN 96 ton 942 kN	297 ton 2910 kN 191 ton 1875 kN 107 ton 1046 kN	2910 kN 1875 kN 1046 kN	3274 kN 2109 kN 1177 kN	3742 kN 2410 kN 1495 kN	4365 kN 2812 kN 1570 kN	5239 kN 3375 kN 1884 kN	3274 kN 2109 kN 1177 kN	3742 kN 2410 kN 1495 kN	4365 kN 2812 kN 1570 kN	5239 kN 3375 kN 1884 kN	267 ton 2619 kN 172 ton 1687 kN 96 ton 942 kN	3274 kN 2109 kN 1177 kN	3742 kN 2410 kN 1495 kN	4365 kN 2812 kN 1570 kN	5239 kN 3375 kN 1884 kN	3274 kN 2109 kN 1177 kN	3742 kN 2410 kN 1495 kN	4365 kN 2812 kN 1570 kN	5239 kN 3375 kN 1884 kN					

Capacity chart SBL900 (metric version) ED.03454.70.001.R00.ENG

Max load per unit	Stage 1:	228.7	Te
	Stage 2:	151	Te

1 st stage 2 nd stage		Position of COG in relation to distance between lifting units																																																																																																																																		
		Y-direction [%]																																																																																																																																		
		0	100	10	90	20	80	30	70	40	60	50	50	60	40	70	30	80	20	90	10	100	0																																																																																																													
Position of COG in relation to distance between lifting units	X-direction [%]	0	229 ton 2244 kN 151 ton 1481 kN	254 ton 2493 kN 168 ton 1646 kN	286 ton 2804 kN 189 ton 1852 kN	327 ton 3205 kN 216 ton 2116 kN	381 ton 3739 kN 252 ton 2469 kN	457 ton 4487 kN 302 ton 2963 kN	381 ton 3739 kN 252 ton 2469 kN	327 ton 3205 kN 216 ton 2116 kN	286 ton 2804 kN 189 ton 1852 kN	254 ton 2493 kN 168 ton 1646 kN	229 ton 2244 kN 151 ton 1481 kN	10	254 ton 2493 kN 168 ton 1646 kN	282 ton 2770 kN 186 ton 1829 kN	318 ton 3116 kN 210 ton 2057 kN	363 ton 3561 kN 240 ton 2351 kN	424 ton 4155 kN 280 ton 2743 kN	508 ton 4986 kN 336 ton 3292 kN	424 ton 4155 kN 280 ton 2743 kN	363 ton 3561 kN 240 ton 2351 kN	282 ton 2770 kN 186 ton 1829 kN	254 ton 2493 kN 168 ton 1646 kN	20	286 ton 2804 kN 189 ton 1852 kN	318 ton 3116 kN 210 ton 2057 kN	357 ton 3506 kN 236 ton 2315 kN	408 ton 4006 kN 270 ton 2645 kN	476 ton 4674 kN 315 ton 3086 kN	572 ton 5609 kN 378 ton 3703 kN	476 ton 4674 kN 315 ton 3086 kN	408 ton 4006 kN 270 ton 2645 kN	357 ton 3506 kN 236 ton 2315 kN	318 ton 3116 kN 210 ton 2057 kN	286 ton 2804 kN 189 ton 1852 kN	30	327 ton 3205 kN 216 ton 2116 kN	363 ton 3561 kN 240 ton 2351 kN	408 ton 4006 kN 270 ton 2645 kN	467 ton 4579 kN 308 ton 3023 kN	545 ton 5342 kN 360 ton 3527 kN	635 ton 6232 kN 419 ton 4115 kN	762 ton 7478 kN 503 ton 4938 kN	635 ton 6232 kN 419 ton 4115 kN	545 ton 5342 kN 360 ton 3527 kN	467 ton 4579 kN 308 ton 3023 kN	408 ton 4006 kN 270 ton 2645 kN	327 ton 3205 kN 216 ton 2116 kN	40	381 ton 3739 kN 252 ton 2469 kN	424 ton 4155 kN 280 ton 2743 kN	476 ton 4674 kN 315 ton 3086 kN	545 ton 5342 kN 360 ton 3527 kN	635 ton 6232 kN 419 ton 4115 kN	762 ton 7478 kN 503 ton 4938 kN	635 ton 6232 kN 419 ton 4115 kN	545 ton 5342 kN 360 ton 3527 kN	476 ton 4674 kN 315 ton 3086 kN	424 ton 4155 kN 280 ton 2743 kN	381 ton 3739 kN 252 ton 2469 kN	50	457 ton 4487 kN 302 ton 2963 kN	508 ton 4986 kN 336 ton 3292 kN	572 ton 5609 kN 378 ton 3703 kN	653 ton 6410 kN 431 ton 4232 kN	762 ton 7478 kN 503 ton 4938 kN	915 ton 8974 kN 604 ton 5925 kN	762 ton 7478 kN 503 ton 4938 kN	653 ton 6410 kN 431 ton 4232 kN	572 ton 5609 kN 378 ton 3703 kN	508 ton 4986 kN 336 ton 3292 kN	457 ton 4487 kN 302 ton 2963 kN	60	381 ton 3739 kN 252 ton 2469 kN	424 ton 4155 kN 280 ton 2743 kN	476 ton 4674 kN 315 ton 3086 kN	545 ton 5342 kN 360 ton 3527 kN	635 ton 6232 kN 419 ton 4115 kN	762 ton 7478 kN 503 ton 4938 kN	635 ton 6232 kN 419 ton 4115 kN	545 ton 5342 kN 360 ton 3527 kN	476 ton 4674 kN 315 ton 3086 kN	424 ton 4155 kN 280 ton 2743 kN	381 ton 3739 kN 252 ton 2469 kN	70	327 ton 3205 kN 216 ton 2116 kN	363 ton 3561 kN 240 ton 2351 kN	408 ton 4006 kN 270 ton 2645 kN	467 ton 4579 kN 308 ton 3023 kN	545 ton 5342 kN 360 ton 3527 kN	653 ton 6410 kN 431 ton 4232 kN	545 ton 5342 kN 360 ton 3527 kN	467 ton 4579 kN 308 ton 3023 kN	408 ton 4006 kN 270 ton 2645 kN	363 ton 3561 kN 240 ton 2351 kN	327 ton 3205 kN 216 ton 2116 kN	80	286 ton 2804 kN 189 ton 1852 kN	318 ton 3116 kN 210 ton 2057 kN	357 ton 3506 kN 236 ton 2315 kN	408 ton 4006 kN 270 ton 2645 kN	476 ton 4674 kN 315 ton 3086 kN	572 ton 5609 kN 378 ton 3703 kN	476 ton 4674 kN 315 ton 3086 kN	408 ton 4006 kN 270 ton 2645 kN	357 ton 3506 kN 236 ton 2315 kN	318 ton 3116 kN 210 ton 2057 kN	286 ton 2804 kN 189 ton 1852 kN	90	254 ton 2493 kN 168 ton 1646 kN	282 ton 2770 kN 186 ton 1829 kN	318 ton 3116 kN 210 ton 2057 kN	363 ton 3561 kN 240 ton 2351 kN	424 ton 4155 kN 280 ton 2743 kN	508 ton 4986 kN 336 ton 3292 kN	424 ton 4155 kN 280 ton 2743 kN	363 ton 3561 kN 240 ton 2351 kN	282 ton 2770 kN 186 ton 1829 kN	254 ton 2493 kN 168 ton 1646 kN	100	229 ton 2244 kN 151 ton 1481 kN	254 ton 2493 kN 168 ton 1646 kN	286 ton 2804 kN 189 ton 1852 kN	327 ton 3205 kN 216 ton 2116 kN	381 ton 3739 kN 252 ton 2469 kN	457 ton 4487 kN 302 ton 2963 kN	381 ton 3739 kN 252 ton 2469 kN	327 ton 3205 kN 216 ton 2116 kN	286 ton 2804 kN 189 ton 1852 kN	254 ton 2493 kN 168 ton 1646 kN	229 ton 2244 kN 151 ton 1481 kN

4.2.2. Minimum load

When the load is only little, the motion of the stages of the booms may not be smooth, due to

- friction in the hydraulic cylinders
- friction in the booms

To ensure smooth motion, the units have to be loaded with at least 50 kN. In most cases the mass of the header beams is sufficient.

Enter the minimum load in the checklist given in Appendix A “Checklist for planning a lifting operation”. Do such for the unit which is bearing the lightest load only.

4.3. Side shift units and lifting lugs

4.3.1. Side shift units

When you want to move the load in transverse direction then you have to apply side shift units.

- Check the capacity of the side shift units, using the information in section 3.2.2 “Operational specifications”.
- Enter the load in the checklist given in Appendix A “Checklist for planning a lifting operation”.



Always determine the force on the side shift units, even for relatively light loads. In case of any doubt, consult Enerpac.



Attention:
The force on the side shift units shall never exceed their bearing capacity.

4.3.2. Lifting lugs

If there is no need to move the load in transverse direction then simple lifting lugs can be applied, rather than the more complicated side shift units.

- Choose single- or double plated lifting lugs, depending on the mass of the load
- Check the capacity of the lifting lugs, using the information in section 3.2.2 “Operational specifications”.
- Populate the checklist given in Appendix A “Checklist for planning a lifting operation” with the mass of the load to be lifted.

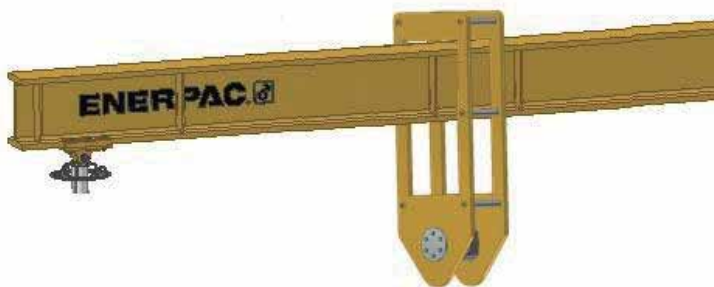

4.4. The bearing capacity of the header beam

The bearing capacity (allowable load) of the header beams depends on the position of the suspension of the load. The closer the load is suspended to the centre of the beam, the less bearing capacity.

The relation between the positions of the suspensions (anchor points) and the allowable load is given in capacity charts. For the capacity charts of Enerpac header beams reference is made to Ref 5 "Technical handbook".

Example how to determine the allowable load of the header beam for two anchor points. Loads within the green area are allowed.

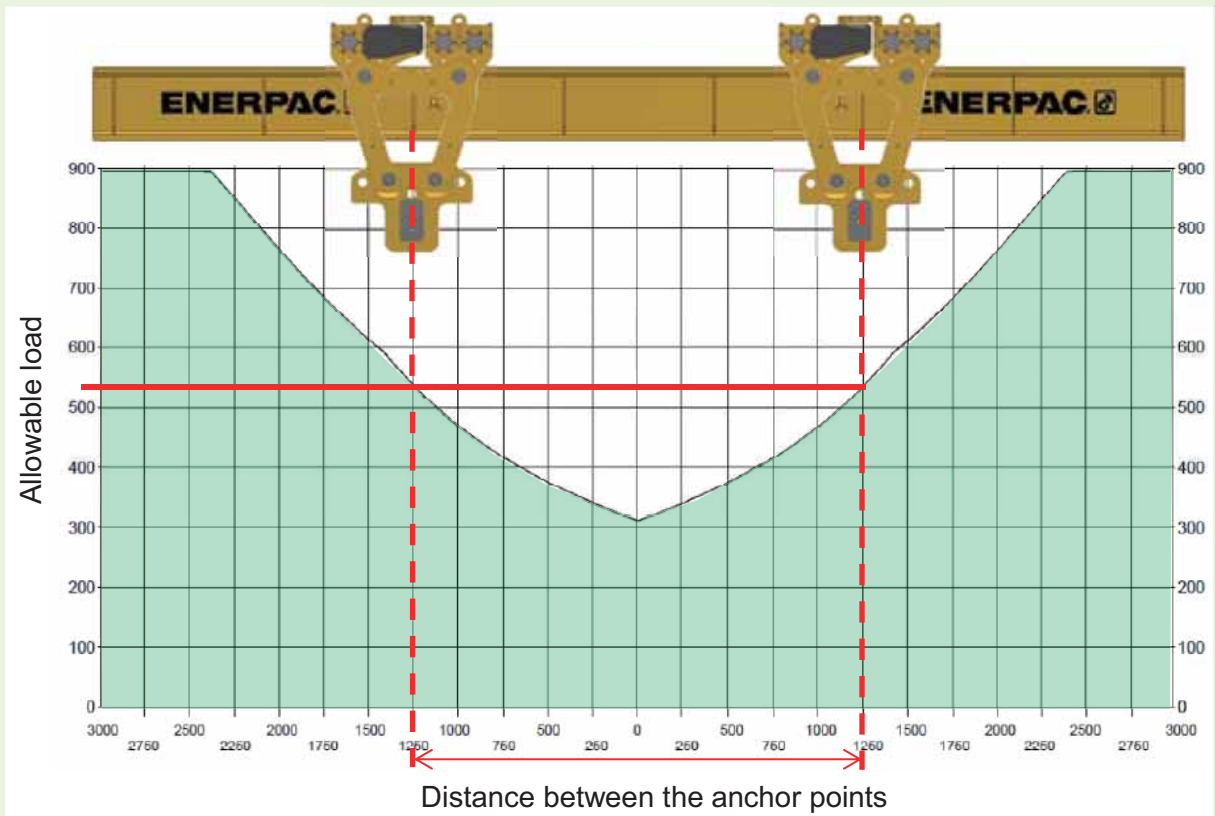

The distance between the anchor points is (1250 + 1250) mm, so the maximum allowable load is 520 kN per anchor point.

When only **one anchor point** is applied then the allowable load can be determined as follows:

1. Read the value of the allowable load from the capacity chart
2. Calculate the distance between the top of the capacity chart and that value
3. Add half of that distance to the indicated allowable load.

Example:

1. Assume the anchor is located in centre of the header beam.
For that location the capacity chart shown below indicates an allowable load of 300.
2. The distance between the top of the capacity chart and the curve is $(900 - 300) = 600$
3. The allowable load is $300 + 600/2 = 600$

Example how to determine the allowable load of the header beam for **one anchor point**. Loads within the green area are allowed.

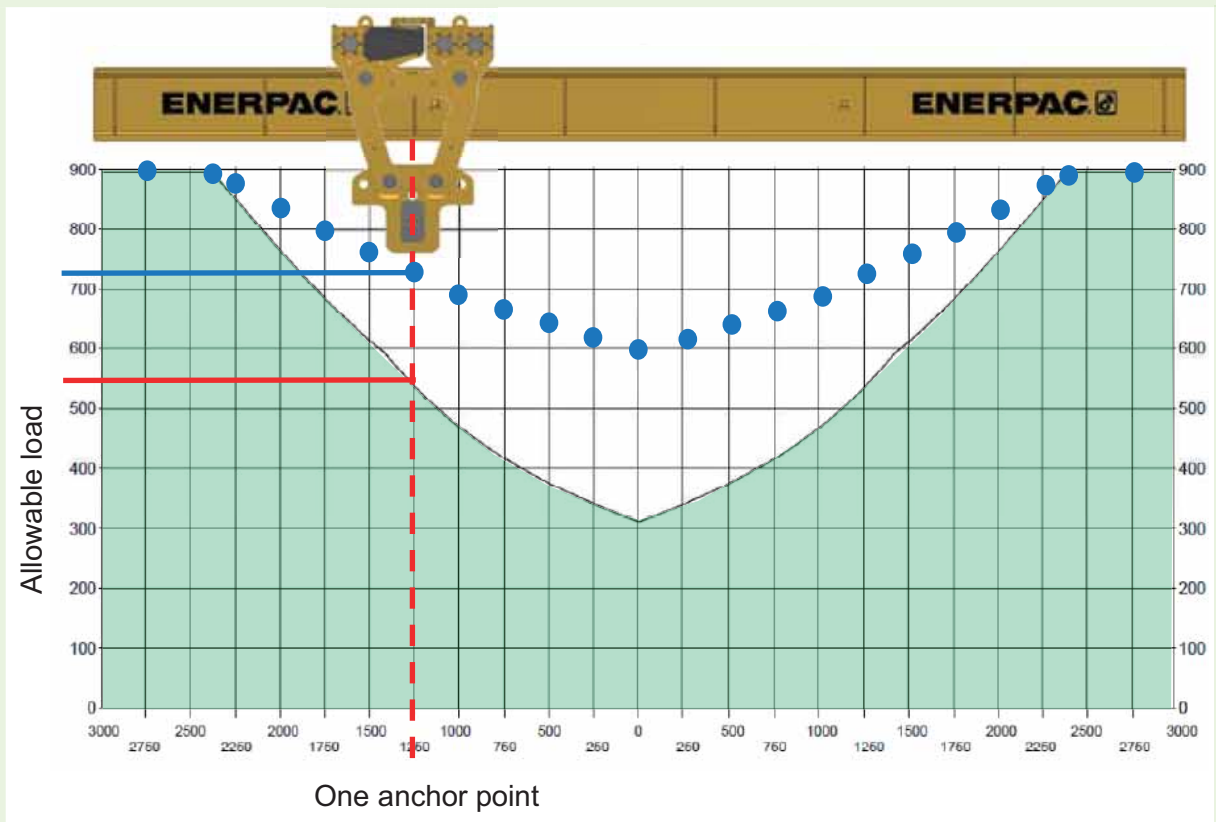

The allowable load is $550 + (900 - 550) / 2 = 725$

Enter the allowable load on the header beam in the checklist given in Appendix A “Checklist for planning a lifting operation”.



Caution: The force on each anchor point shall not increase the capacity of the header beam.



- Earlier purchased Enerpac / Hydrosplex header beams may be applied if their capacity is sufficient.
- Header beams of foreign make can be applied if their capacity is sufficient, but Enerpac will not take any responsibility for it.

4.5. Side load

Side load may endanger the stability of the System. It can be caused by

- wind
- skid tracks not level
- system not mounted plumb
- slings or shackles not plumb

During activities in the open air, wind exerts may put force on the lifted object. Therefore, for every lifting operation the maximum permissible side load has to be calculated. The permitted side-load on the System is **1.5%** of the actual load.

Enter the max expected side-load Appendix A “Checklist for planning a lifting operation”.

The side load caused by wind depends on

- the size of the object
- the wind speed
- the height of the header beams (lifting height).

To calculate the permissible wind speed you may apply the provided calculation program; see Ref 4 “USB stick Wind calculations”. The program calculates the permissible wind speeds in both directions under different circumstances.

The used parameters are indicated in the illustration below.

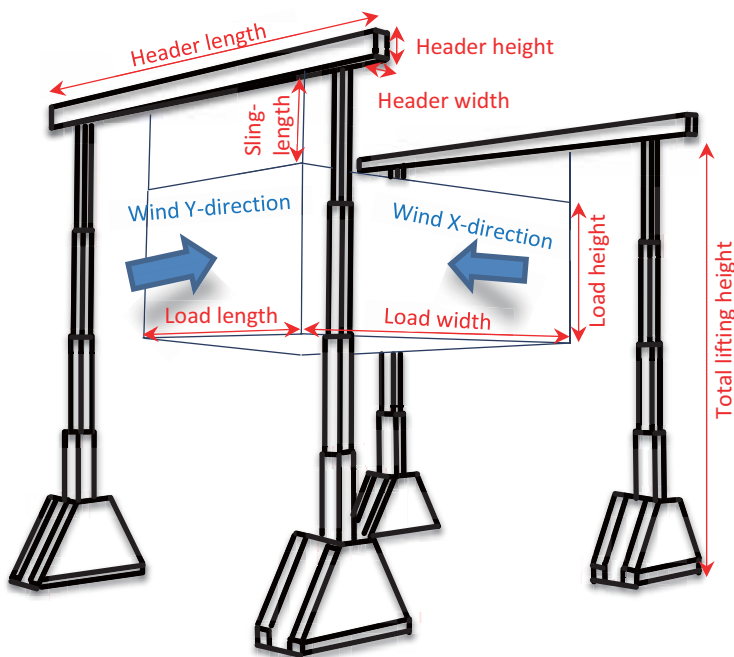

Example of a completed form:

Load Properties		
Load width	4	<i>m</i>
Load length	5	<i>m</i>
Load height	3	<i>m</i>
Load weight	1250	<i>kN</i>

Operational parameters		
Total lifting height	7.0	<i>m</i>
Sling length	0.5	<i>m</i>

Header geometry		
Header width	0.33	<i>m</i>
Header length	6.00	<i>m</i>
Header height	0.40	<i>m</i>

Cross Beam parameters		
Beam width	0.33	<i>m</i>
Beam length	6.00	<i>m</i>
Beam height	0.40	<i>m</i>

Wind parameters		
Max. wind velocity X-direction	17.8	<i>m/sec</i>
Max. wind velocity Y-direction	15.6	<i>m/sec</i>

The calculation program takes the dimensions of the foot of the System in account. Those dimensions are implemented as fixed parameters and cannot be altered.



- Always assume the most adverse situation
- Populate the checklist in Appendix A “Checklist for planning a lifting operation” with the maximum permissible wind speed.



Hazard:

- Under no circumstances whatsoever lifting operations may be carried out when the wind speed is exceeds the permissible values
- When lifting, assume a worst-case scenario. Wind is unpredictable and may quickly change speed and direction.

5. Install the System

This chapter describes how to install the System, including the preparation of the working location.

For torque settings reference is made to Appendix L.

 Enerpac only guarantees System integrity when exclusively Enerpac products are applied.

5.1. How to hoist parts of the System

5.1.1. Hoisting units

Pre-conditions for moving a unit:

- no header beams are mounted
- no load is attached
- the boom is in horizontal position

The units can be moved in two ways:

- A. Using a **forklift** truck.
Use the fork holes of the unit.



In order to prevent damage to the wheels of the units:

- keep the bottom of the unit at a height of at least 300 mm
- the unit should not lean back



- B. Using a **crane**.
Use the lifting eyes of the unit.



Attention: always use both lifting eyes

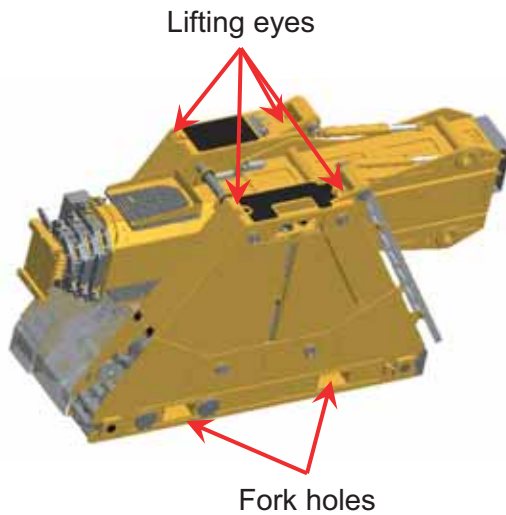

 Always keep the unit in vertical position

5.1.2. Hoisting the Skid tracks

The skid tracks can be hoisted:

- by a forklift truck.
Use the fork holes
- by a crane.
Use the two lifting eyes.

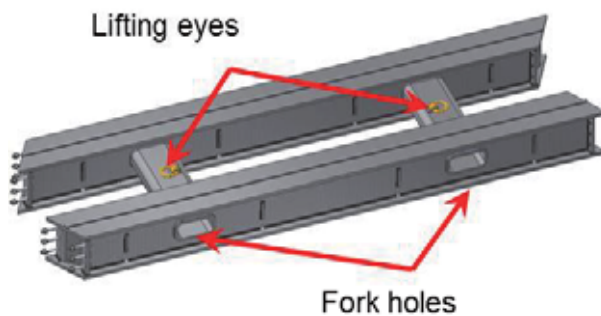

5.1.3. Hoisting the header beams

Header beams are provided with lifting eyes.

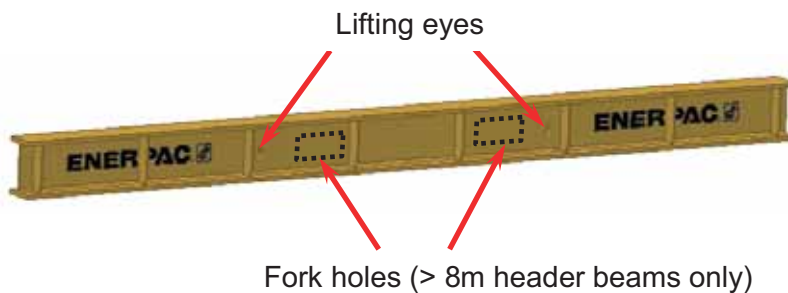

5.1.4. Hoisting the side shift unit

To hoist the side shift units regard the following.
The descriptions are given for the HBS6000 only, but are valid for the HBS3000 as well.

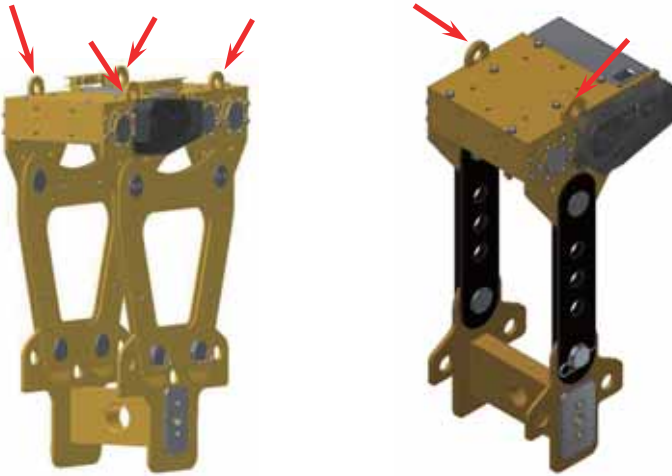

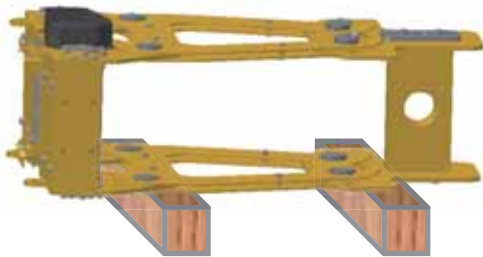

The side shift units shall only be hoisted using the lifting eyes. When not in use then put the side shift units down horizontally. Put them on timbers.

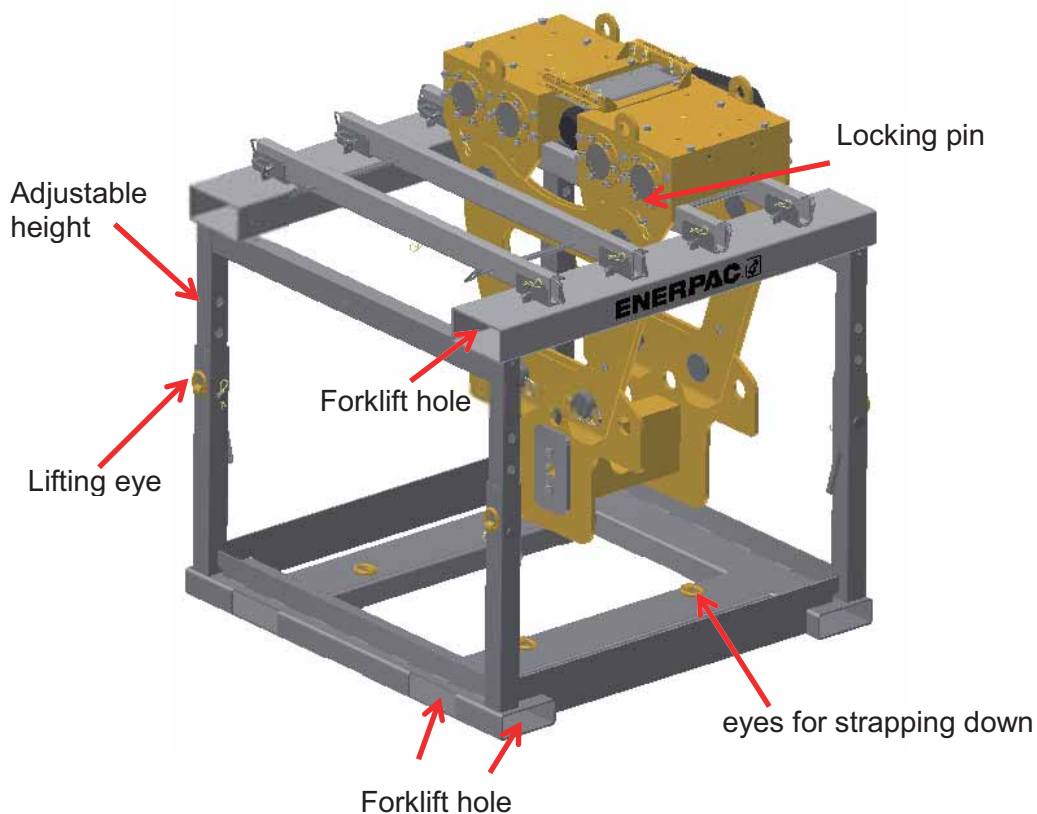

Optionally, transportation frames may be delivered for transporting and storage.

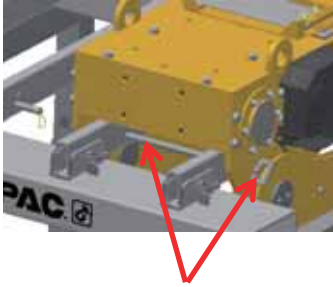

To get the side shift unit out of the transportation frame proceed as follows:

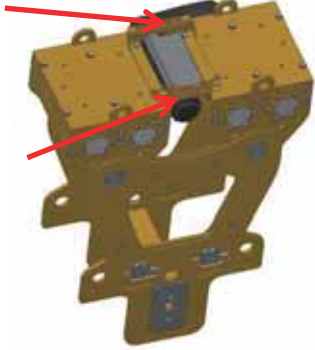
1.	Put the transportation frame next to the gantry. Preferable apply a forklift . Eventually you can use a crane and use the lifting eyes.	
2.	At delivery, the side shift units are strapped to the strap-down eyes. Remove those straps.	
3.	Remove the locking pin	
4.	Store the locking pin in one of the pipes	
5.	For HBS6000: remove the locking plates.	
6.	Hoist the side shift unit out of the transportation frame. Use all four lifting eyes.	

For storing the side shift units in the transportation units, proceed in reverse order.

Pay attention to the following:

- The height of the transportation frame is adjustable. Make sure the height is set in such a way that the side shift units cannot touch the ground.
- Strap the side shift units to the strap-down eyes.

5.2. Place the Skid Tracks

Correct positioning of the skid tracks insures that the System is put level on the ground. When the ground is not flat then grade it in advance, to create a solid foundation on which the system can operate safely.



Attention: creating a proper foundation has to be performed with utmost care, as it is the system's primary safety issue. The foundation of the Skid tracks is the exclusive responsibility of the user.

5.2.1. Build the foundation

For building the foundation, proceed as follows:

Install the foundation material as you determined; see section 4.1. "Ground bearing pressure calculation".

Regard the following aspects:

- If the diameter of the timbers is not square then put them in flat position.

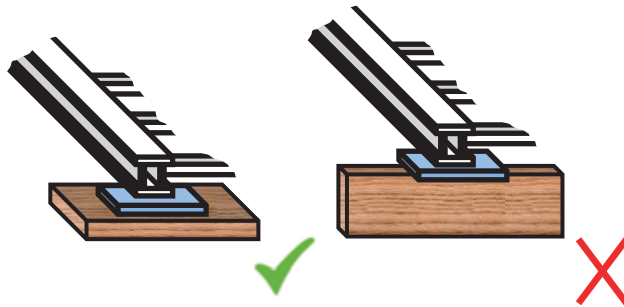

- If you stack timbers then leave no slack in between, to avoid risk of spring.

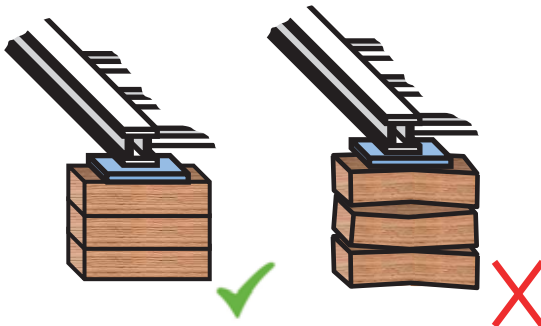

- Put the timbers horizontally, not vertically.

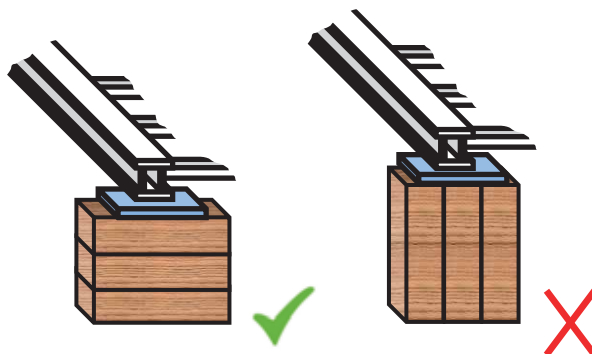

5.2.2. Put the skid tracks in place

For putting the skid tracks in place, proceed as follows:

Put the skid tracks on the foundation and mount them together.

Regard the following aspects:

- Put steel plates between the timbers and the skid tracks

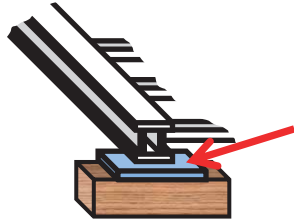

- Make sure no slack is left between the foundation and the skid tracks. Eventually use shims.

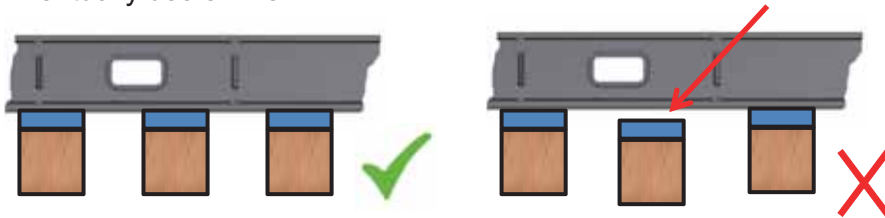

- Put foundation material directly underneath the couplings of the skid tracks:



5.2.3. Align the skid tracks

Align the Skid tracks according to the following requirements:

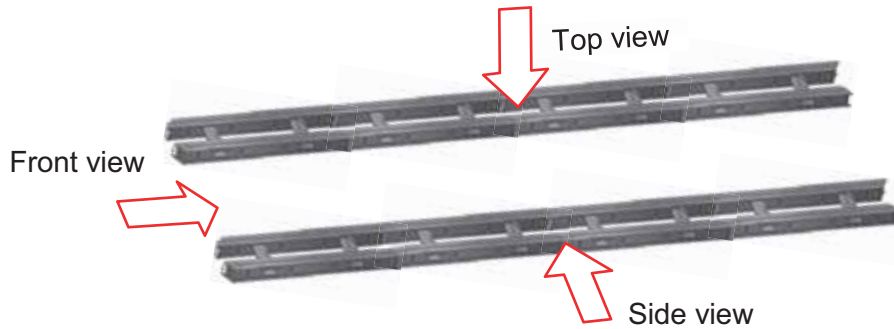

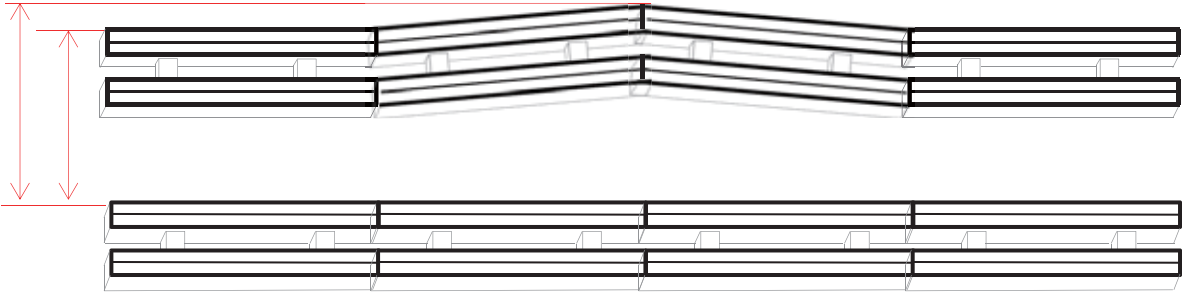
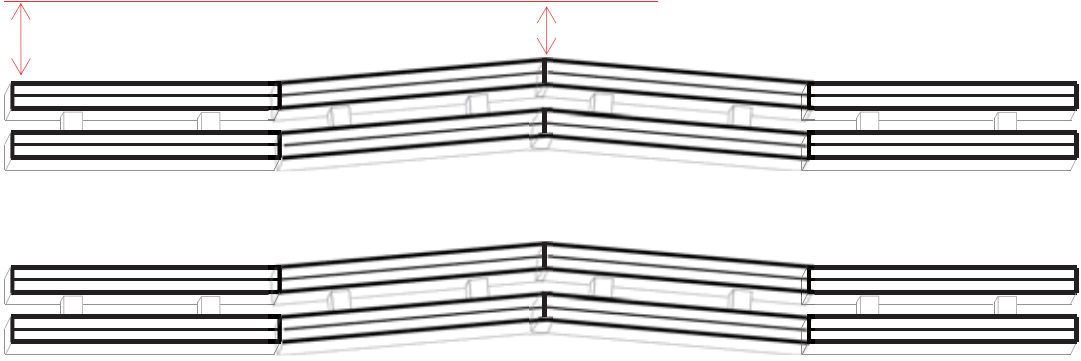

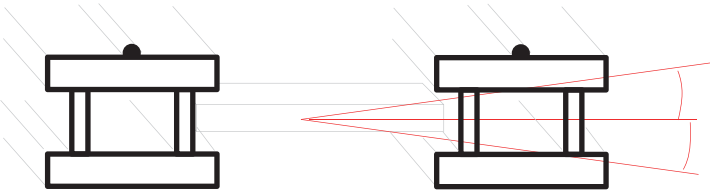
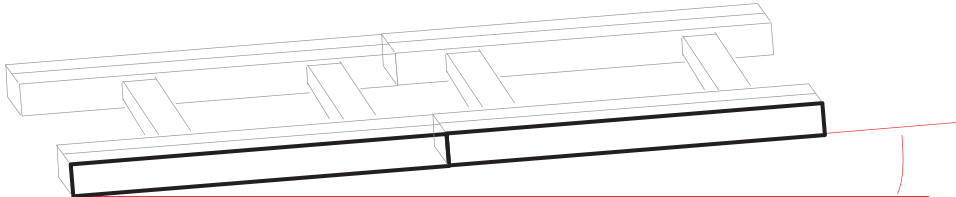
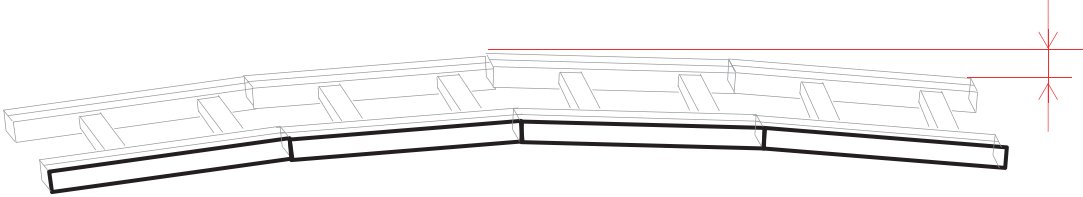
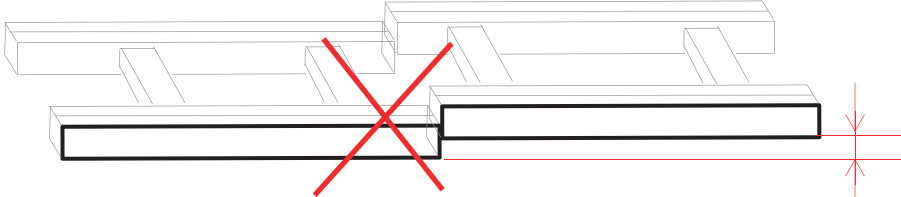
Nr	Alignment requirement	Tolerance
1	The skid tracks shall be in parallel	13 mm
 <p>(top view)</p>		
2	The skid tracks shall be aligned from the start to the end	12 mm
 <p>(top view)</p>		

3	The skid tracks shall have now skew	0.25°
 <p>(front view of one skid track)</p>		
4	The skid tracks shall not incline	0.2°
 <p>(side view of one skid track)</p>		
5	The skid tracks shall be flat	8 mm over 3 meter
 <p>(side view of one skid track)</p>		
6	The surfaces of the segments of the skid tracks shall be well aligned. <i>Use shims if necessary</i>	-
 <p>(side view of one skid track)</p>		

5.3. Put the units upon the skid tracks

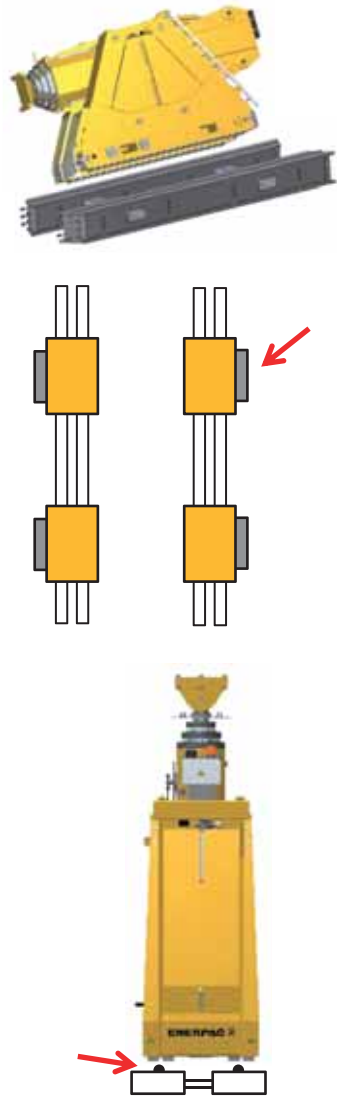
To put the units upon the skid tracks proceed as follows:

<p>1. Put the units on the skid tracks</p> <ul style="list-style-type: none"> • Regard the hoisting instructions as given in paragraph 5.1.1 “Hoisting units”. • Put all units with the electro cabinet towards the outside. • The grooves in the roller tracks have to match with the ridges on the skid tracks. 	
<p>2. Set the moving direction of all units in such a way that they travel in the same direction. Use [5] on the control panel; see section 6.2.1 “The switches and indicators”.</p> <p>(Do this after the power has been connected)</p>	

5.4. Connect the power cables

Connect the power cables to units. Use the sockets on the electrical cabinet.



Don't bother the phase of the power since the units feature automatic phase detection. This assures the correct rotation direction of the electro motors.

There are two options for connecting the units:

- connect each unit individually to the main power.

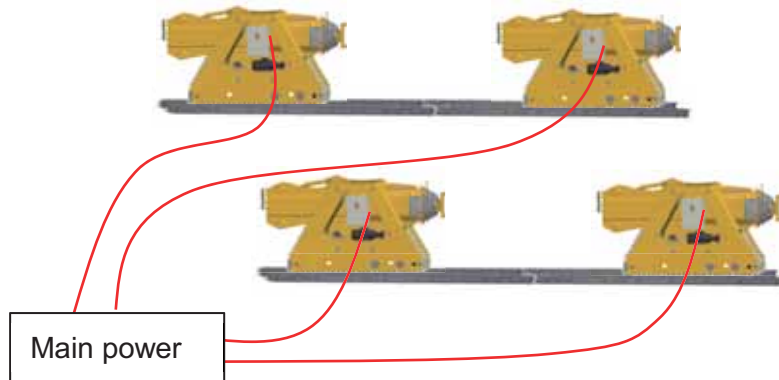

- connect the units two-by-two to the main power.

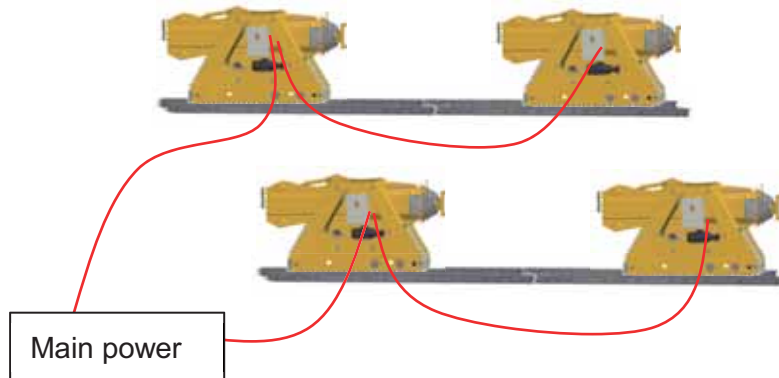

The two power sockets of a unit are functional equal: both can be used for power input and power output.



Do not interconnect more than two units.

5.5. Put the boom in upright position

For putting the boom in upright position the system is operated local control. So, use is made of the buttons on the control panel; see section 6.2.1 “The switches and indicators”. The unit has to be connected to electric power.









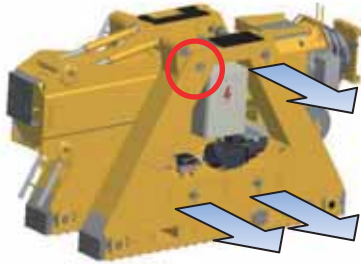

Attention:

Never put the boom in upright position or lower it

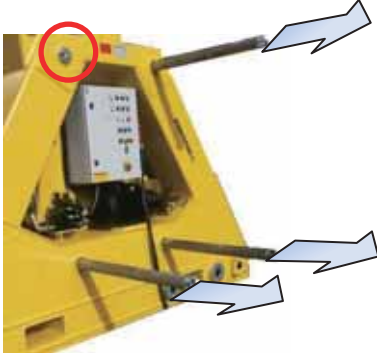
- when something is attached to it.
The tilting cylinders are not designed to bear additional weight.
- while the boom is extended.
The unit might tumble due to the different centre of gravity

Proceed as follows:

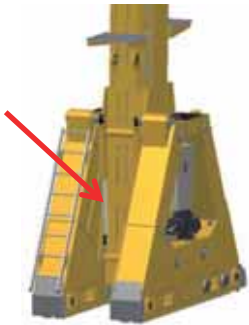
<p>1. Remove the three lifting shafts from the frame:</p> <ul style="list-style-type: none"> • Remove the spring clips from the three shafts • Pull the three indicated shafts out until the red indicators <p> Leave the fourth shaft (not provided with a clip) in place; it serves as the axe for the rotation of the boom.</p>	   
--	--

2.	<p>Check:</p>  <ul style="list-style-type: none">nobody is close to the unitno cables can be pinchednothing is attached to the boom	
3.	<p>Use the buttons on the control panel to raise the boom; see section 6.2. "The Control Panel of the unit".</p> <p><i>The tilting cylinders extend.</i></p> <p><i>The boom gets in upright position.</i></p>	  

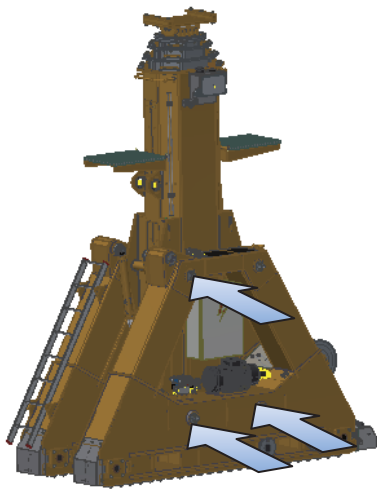
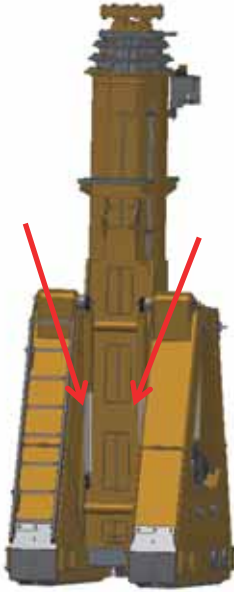
<p>4. Put the shafts back into position and lock them with the spring clips. <i>Play with the buttons on the control panel for fine-positioning, to enable restoring of the shafts.</i></p> <div style="display: flex; align-items: center; margin-top: 20px;">  <p>Hazard: A missing shaft may result in an unstable unit foot and thus also an unstable system.</p> </div>	
<p>5. Decompress the tilting cylinders by retracting them slightly, using the buttons on the control panel. Keep an eye on the pressure gauge; there should not be pressure built up.</p>	

5.7. Mount the header beams



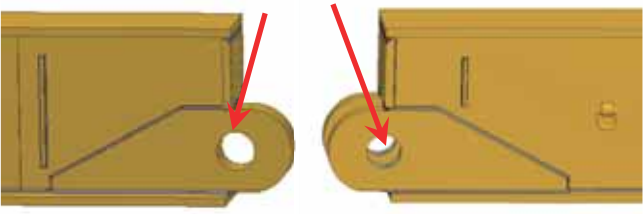
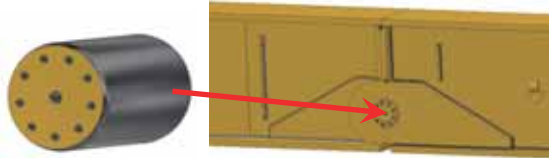
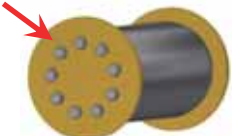
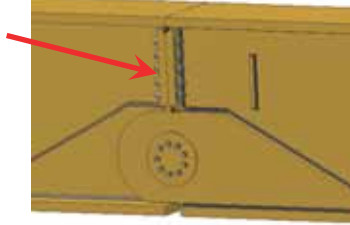

5.7.1. Assemble the modular beam

When you apply the modular header beam then construct it as follows:

<p>1. Put two sections male / female together and align the holes</p>	
<p>2. Mount the connection bolt</p>	
<p>3. Mount the flanges of the connection bolt</p>	
<p>4. Tighten the bolts according to the table in Appendix 0 "Torque settings".</p>	

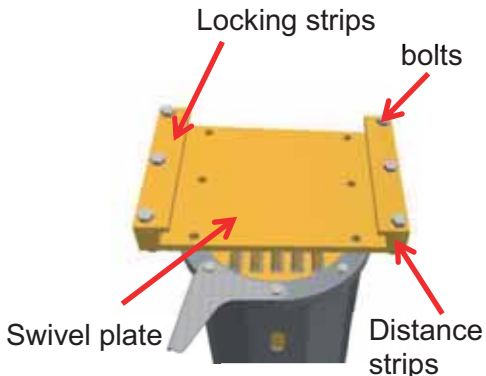

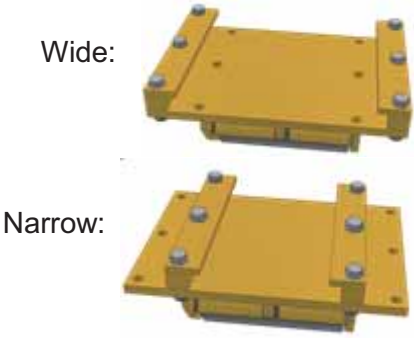

5.7.2. Mount the header beam on top of the boom

To mount the header beams on top of the boom proceed as follows:

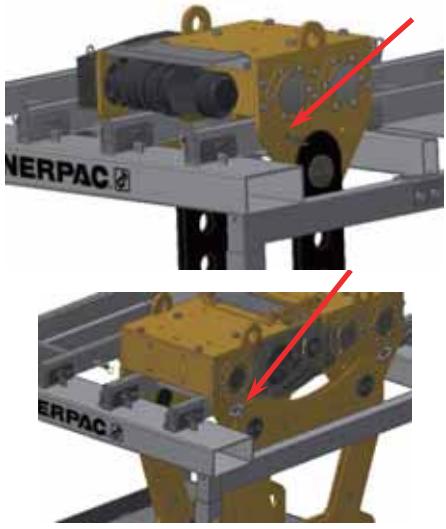

1.	Remove the six bolts at the top of the swivel plate	
2.	Remove the locking strips.	
3.	Put the header beam on top of the swivel.	
4.	<p>Clamp the header beam to the swivel using the distance strips and the locking strips.</p> <p>Note that two types of beams can be mounted:</p> <ul style="list-style-type: none"> • Wide (480 mm) • Narrow (300 mm) <p>Set the locking strips of the swivel according to the applied type.</p>	
5.	Level the beam. Use [1] of the control panel (see page79).	
6.	<p>Tighten the bolts according to the table in Appendix 0 “Torque settings”.</p> <ul style="list-style-type: none"> •  Make sure that all bolts are tightened properly. • Always apply all bolts 	

5.8. Put the side shifts on the header beams

To put the side shifts to the header beams, proceed as follows:

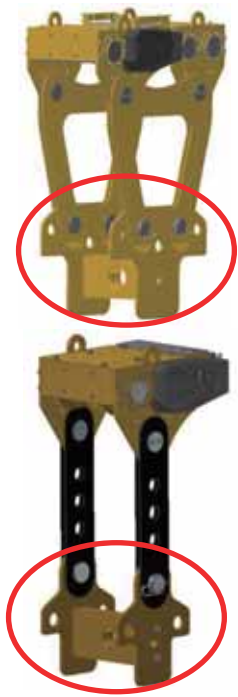
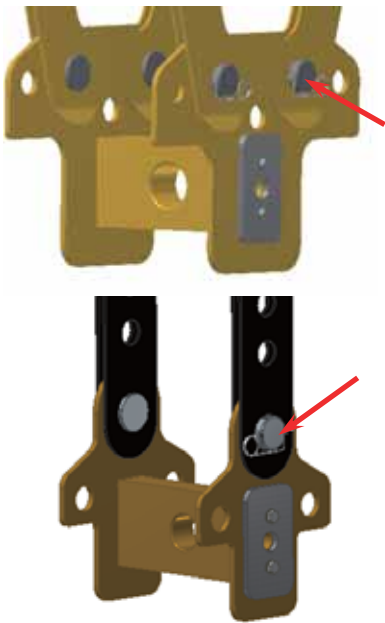
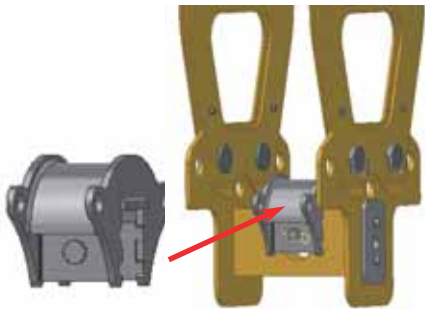
<p>1.</p>	<p>Mount the cable-guiding wheel at the header beam.</p>	
<p>2.</p>	<p>Hoist the side shift unit out of the transportation frame. Both types of side shift units are depicted.</p> <p> Remove the locking pins.</p>	
<p>3.</p>	<p>Put the side shift on the header beam.</p> <p> Preferably put the side shift units with their chain-boxes at the same side of the header beam. This makes setting of the running direction of the side shift units more logical.</p>	

4.	Place the anchor block.	
5.	Lock the bolts with the locking pins	
6.	When you're going to apply slings then mount the sling tool.	

7.	<p>Connect the cable on the cable reel with the side shift</p> <p> Ensure that the cable is mounted in such a way that it cannot get pinched.</p>	
8.	Mount the other side shift similarly.	
9.	<p>Set the moving direction in such a way that side shift units will move in the same direction. Use [5] on the control panel; see section 6.2.1 “The switches and indicators”.</p> <p>(This may be done in a later phase when the units have been provided with electric power, e.g. section 7.7. “Move the load in transversal direction”).</p>	

5.9. Mount the longitudinal beams

When you apply longitudinal beams, make sure those longitudinal beams are securely fastened to the header beams.

For header beam configurations reference is made to section 3.3.1 Header beam configurations”.



Enerpac provides a solution for mounting longitudinal beams.
Contact Enerpac if you want to apply longitudinal beams

5.10. Check the stroke sensor

Though the wire of the stroke sensor is not a removable part, its presence and the correct mounting has to be checked due to its vulnerability.

Proceed as follows:

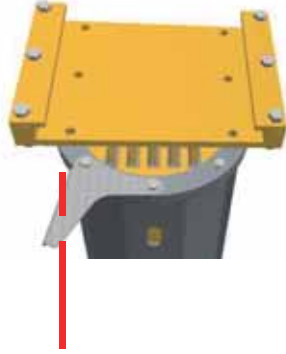
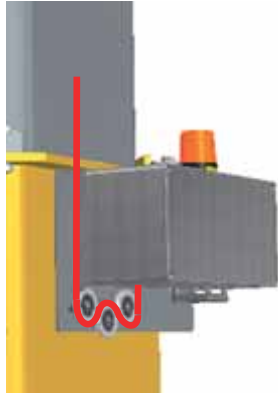
<p>1.</p>	<p>Verify that the wire is connected to the strip on top of the boom</p>	
<p>2.</p>	<p>Verify that the wire is attached to the electrical box and follows the guiding wheels in as indicated.</p>	

5.11. Install the remote control console (RCC)

The RCC can communicate with the units:

- wireless, using radio
- wired, using data cables

5.11.1. Wireless communication

The RCC enables wireless on a radio frequency of 2.4 GHz.
No cables have to be connected.

BUT:

The wireless communication may be disturbed.

If so, a report is given on the LCD per Unit: ***** Communication-time-out *****

The disturbance may be caused by radio reflections or 'dead' area's. Walking to another position may help

Connection-fail measures:

- If the communication fails for 2 seconds then all movements of the units and the side shifts are stopped.
- If the communication fails for 10 seconds then the system makes an Emergency stop. For recovering from this situation reference is made to section 6.1. "The Emergency buttons".



5.11.2. Wired communication

Wired communication is preferable when the radio link is disturbed.

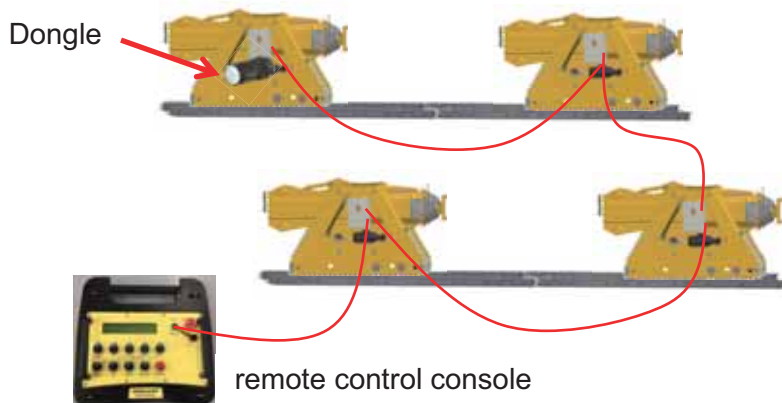
To enable wired communication between the RCC and the four units, the following configuration has to be set up:



Proceed as follows:





1.	Make sure the RCC is switched off	
2.	Make sure the power of all units is switched off	
3.	Connect the data cable to the RS-485 socket of the RCC.	
4.	Connect the data cable to one of the units. Each units are provided with two RS485 sockets. Use one of them; the sockets are functionally identical.	
5.	Connect another data cable to the other socket of the unit and connect it to the next unit.	
6.	Carry on connecting until all units are connected. The sequence in which you interconnect the units does not matter since the units will identify themselves automatically.	
7.	Provide the unused socket of the last connected unit with the Dongle	



5.11.3. Set up the communication

To set up the communication between the RCC and the four Units to work, proceed as follows.

Reference is made to

- the controls on the RCC as “RCC[x]”.
The layout of the RCC is given on page 81.
- the Control Panels of the units as “UNIT[x]”.
The layout of the control panel is given on page 79.

1.	Connect data cables or do not so. The system will automatically detect their presence.	
2.	Ensure that the “Emergency stop” button on the RCC is in the non-activated position.	
3.	Switch the main power switches on the control panels of all units to “on”. <i>The “power on” indicator on the control panel of the Units will be lit.</i>	
4.	Make sure that the “Emergency stop” buttons on all units’ are in the non-activated position. The blue indicator should be dimmed.	
5.	Switch the unit to Remote	
6.	Select the Units you want to operate with. <i>The RCC can now detect the units.</i> <i>If the connection with a unit is fine than the “emergency active” indicator on the control panel of that unit is dimmed.</i>	

7.	Switch the same switches to off again	
8.	<p>Switch the RCC off and on</p> <p><i>As soon as the communication is established:</i></p> <ul style="list-style-type: none"> • <i>the text "Engine still" is displayed</i> • <i>an asterisk is displayed</i> <p><i>If the RCC detected data cables then the wireless means are switched off.</i></p> <p><i>Now it is possible to control the units.</i></p>	





5.11.4. Reprogram the communication



Each RCC is provided with a unique code. This code is known by the receivers of the units, so they can recognize their Master's Voice.



Enerpac has set this communication configuration initially.
The setting is persistent and remains after switching off the power.
Only when the RCC or one of the units was replaced, reprogramming is required.

Reprogramming has to be performed for each unit individually.
Proceed as follows:

1.	Make sure the battery of the RCC is charged	
2.	Switch the units off.	
3.	Use the switches to deselect all units.	
4.	Switch the unit which has to be programmed on.	
5.	Select the concerned unit	
6.	Open the electro cabinet of the unit. Look for the receiver..	

<p>7.</p>	<p>Press "LEARN" for two seconds</p> <p><i>When the tekst "NO ANSWER" disappears from the display of the RCC, the RCC and the unit are connected.</i></p>	
<p>8.</p>	<p>Eventually repeat [2] .. [7] for the other units</p>	
<p>9.</p>	<p>Verify that the number on the RCC match with the numbers on the units, by travelling with the units individually.</p>	

5.12. Perform an all-over visual inspection of the System

Inspect the System visually.

Enter the result of the inspection in the checklist given in Appendix B "Checklist for installing the System".

6. How to control the System

6.1. The Emergency buttons

The system is provided with emergency buttons.

- On the control panels of all four units.

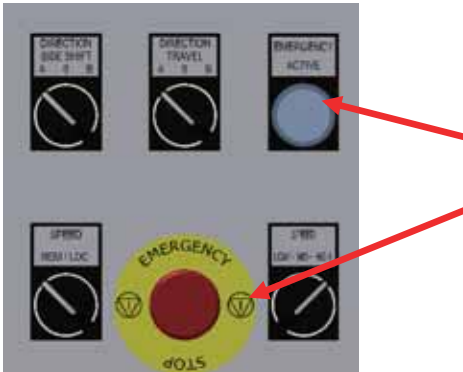

When the button is pressed:

- the unit is switched off
- the blue button “Emergency active” is lit
- if the unit is in Remote Control then other units which are in Remote Control too are switched off as well.

To recover the system from an Emergency situation:

- investigate why the button was pressed
- turn and pull the emergency button
- press the blue button

- On the RCC.



When the button is pressed:

- all units which are in remote control are switched off

To recover the system from an Emergency situation:

- investigate why the button was pressed
- switch off the main power of all units for at least 20 seconds
- restart the system

6.2. The Control Panel of the unit

6.2.1. The switches and indicators

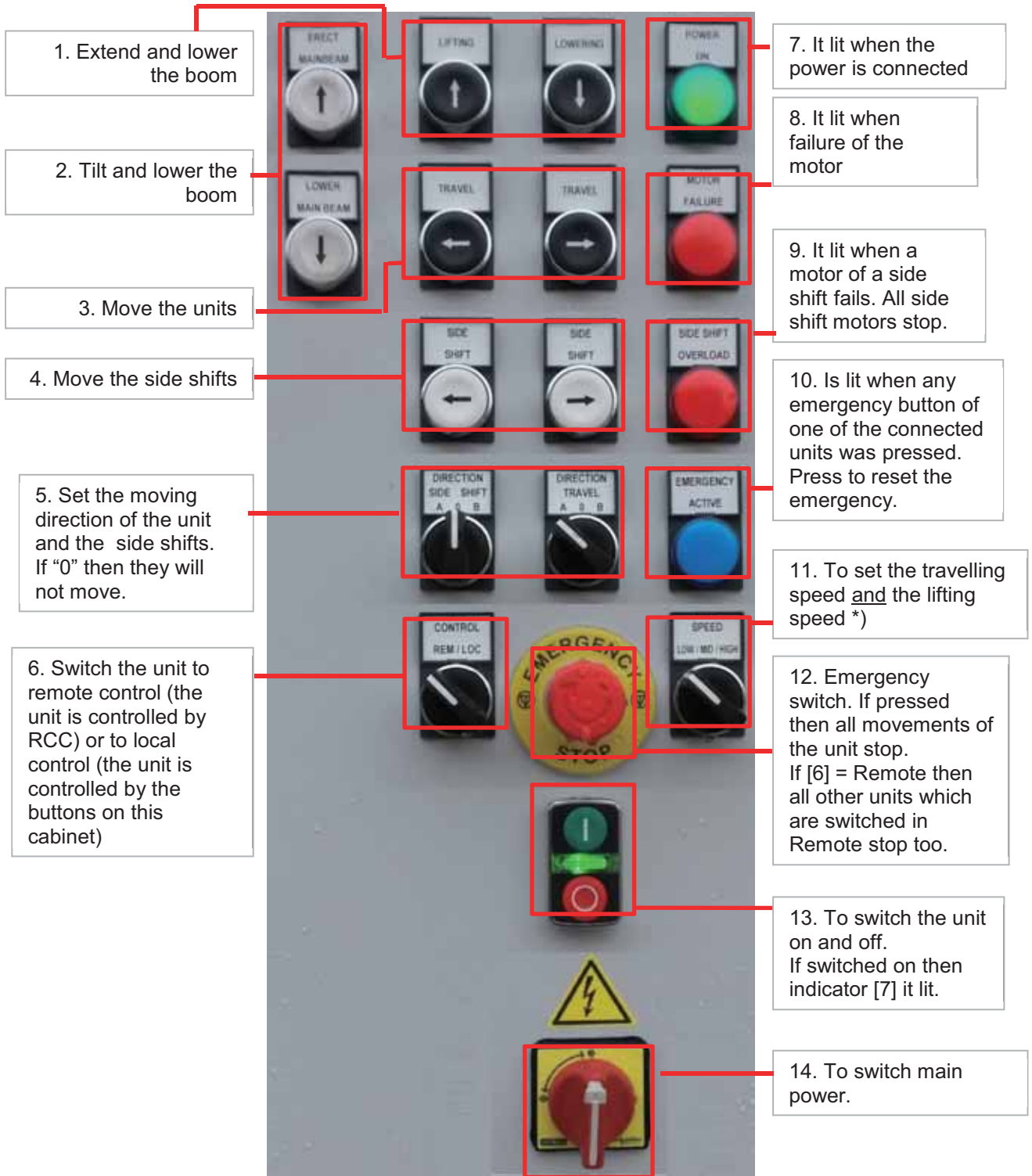

*) Ad [11]: If the system detects a load > 10% of the maximum load or the boom is extended for more than one stage then the speed is automatically set to Low, regardless the system is in Local control or Remote control.

6.2.2. Local control mode

The control panel of a unit enables the operator to control only the unit on which it is mounted. Other units cannot be controlled.

Let's call this mode "Local Control".

Local control is meant to be used during the setting-to-work phase of the System:

- to manoeuvre the units into position
- to put the booms in upright position
- to manoeuvre the side shifts into position
- to set the positive running directions of the unit and the side shift.

For Local Control proceed as follows:

1. Switch the unit on; use [14] and [13].
Verify that [7] is lit, and [8] and [9] are dimmed
2. Use [6] to enable Local Control

In local control the following operations can be executed:

- Set the positive running direction of the unit; use [5]
- Set the positive running direction of the Side Shift; use [5]
- Extend or lower the boom; use [1]
- Travel the units forward and backward; use [3]
- Move the side shift towards the left and the right; use [4]
- Put the boom in upright position; use [2]



Attention:

Never use local control when header beams are mounted, since:

- In local control the units are not controlled simultaneously.
- In local control no load detection is performed.

6.3. The remote control console (RCC)

The RCC enables the operator

- to execute a lifting operation on a safe distance
- to control all units simultaneously

Let's call this mode "Remote control".

Applying the RCC ensures that

- the moving speeds of the units is synchronized
- the heights of the booms during a lift operation are kept equal within a tolerance of 24 mm.

The RCC cannot control the tilting cylinders, used for putting the boom in upright position.



System start up is faster when the RCC is switched on before the units are switched on.

6.3.1. The controls

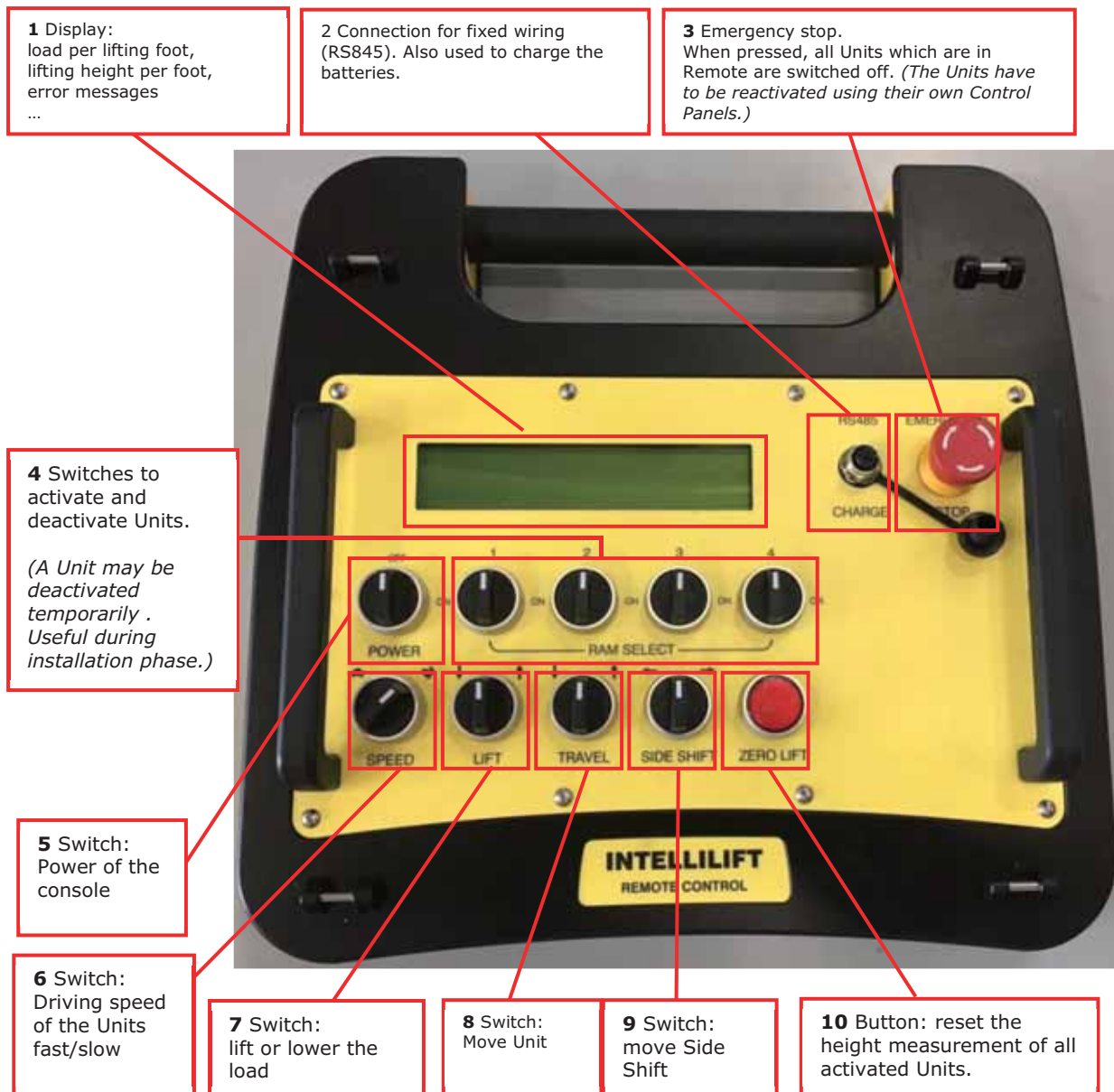

ad [6]:

The system can operate in “fast” (which is valid for lifting,/lowering and travelling) when

- The load on all units < 45 kN
- The cylinders are not extended in stage 2

Otherwise the system automatically operates in “Slow”

6.3.2. The display

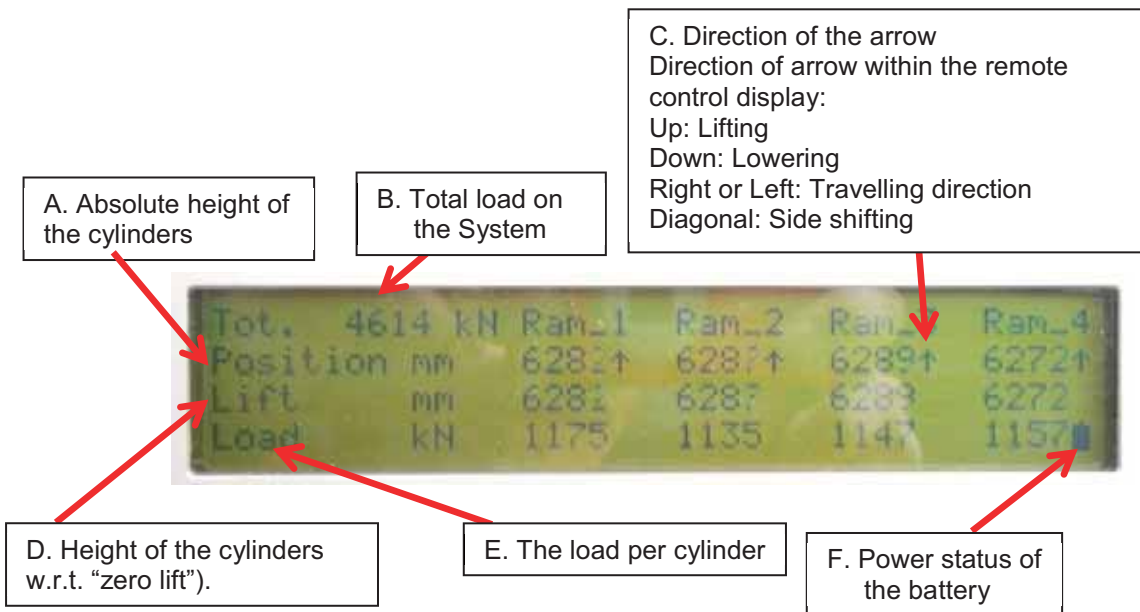

The following values are displayed on the screen:

- **Tot.**
The total load on the selected units
- **Position**
The height per cylinder
- **Lift**
The height with reference to the zero lift position
- **Load**
The load per cylinder
 - The load is a calculated value, based on the position.
Changes in the indicated position may cause a jump in the load indication.
 - The values indicated for the non-selected cylinders are invalid.
- **Warnings and errors** are displayed on the top line:

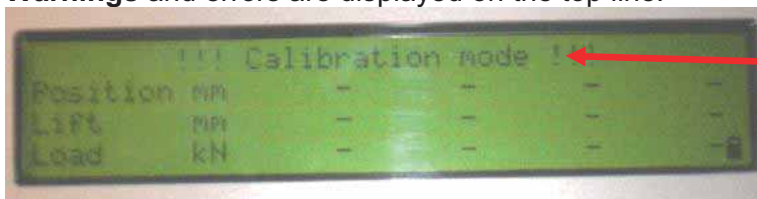

A list of possible errors and warnings is given in Paragraph 8.2. "List of problems and solutions" under "Reports on the display of the Intellilift Console".
When communication with the Units is OK, an asterisk is shown behind the Lift value.

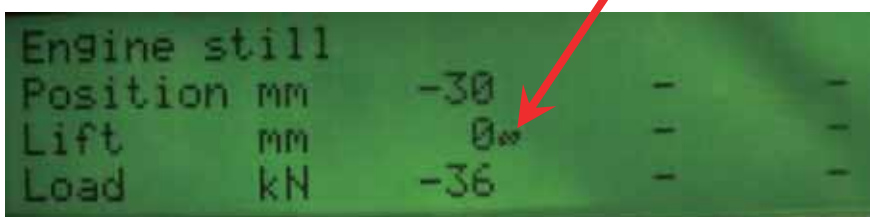

- The display is provided with **background lighting**. In order to extend the battery life, the background lighting is switched off if no changes are detected for a period of 15 seconds.
- **Emergency pressed**
The report "****Emergency pressed****" is shown:
 - When the emergency button on the remote control console was pressed

- When the emergency button on a unit was pressed, but only when that unit was on Remote control. Reference is made to section 6.1. "The Emergency buttons".
- **Battery level**

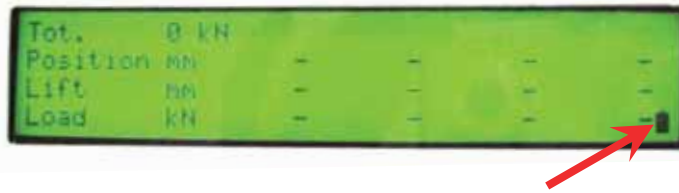

The display shows the power level of the battery.
The console can operate approximately 8 hours on a fully charged battery.
Switch the console off after use and connect it with the 12V loader.



Only apply the delivered loader.

6.3.3. Calibrate the stroke sensor







This paragraph describes how to calibrate the stroke sensor, which measures the height of the boom.

Reference is made to the layout of the remote control console on page 82.

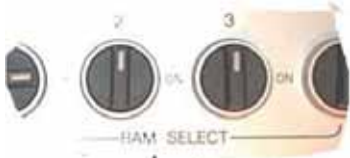

Calibration has to be performed when stroke sensors were changed, so calibration is **not part** of the daily routine.

Proceed as follows:

1.	<p>Preconditions:</p> <ul style="list-style-type: none"> • RCC switched off • Units switched off. 	
2.	Set "Speed" on the RCC to the 'hare' (high speed)	
3.	<p>Press "Zero lift" and keep it pressed while you switch the console on.</p> <p>Keep "Zero lift" pressed until the message "System not ready" is shown</p>	
4.	<p>Release the "Zero lift" button.</p> <p>The RCC is now in calibration mode.</p> <p>The "Calibration mode" message appears on the display.</p>	
5.	Switch the unit which you want to calibrate on and start its motor.	
6.	Select the unit on the RCC	
7.	Retract the cylinders to the very minimum position	

8.	Extend the cylinders to the very maximum position	
9.	Deselect the unit <i>The stroke sensor has been calibrated.</i> <i>The message "Calibration succeeded" is shown.</i>	
10.	Switch the RCC off.	
11.	Switch the RCC on.	
12.	Verify the displayed position. It should be the maximum position.	
13.	Retract the cylinder to the very minimum position.	
14.	Verify the displayed position. It should be approx. 0.	

7. Execute a lifting operation

This chapter describes how to perform a lifting operation.

7.1. Risks and Warnings

Good operation of the System is essential for safety. Therefore, address the following subjects:



Attention

- It is of the utmost importance to **read this manual** carefully before setting up the machine. Failure to prepare correctly for a lifting operation may result in total loss of machine stability during use.
- Adhere to the **checklists** during all work activities: during preparation for the lifting operation, system construction, and for lifting the load.
- A unit is only part of the central emergency stop system if the control selector switch is in the **remote position**.
- Ensure that the load avoids **contact** with a leg, header beam, other components of the system or any obstructions while lifting, side shifting, or traveling.
- The operator should have an **unobstructed view** of the system and load during operation of the system. If this is not possible, a signalperson shall be used with an effective means of communication to provide directions to the operator.
- Communication among personnel involved in the operation shall be maintained continuously during all movement of the load. If at any time communication is disrupted, the operator shall stop all movements until communication is restored.
- **Signals** to the operator should be in accordance with the standards prescribed in section 1.8.6 "Hand signals". If special signals are required, they shall be agreed upon by the operator and support personnel prior to the lifting operation. Signals shall be discernible or audible at all times. No action shall be taken unless signs are clearly understood.
- Load handling personnel **shall obey** any stop signal.



Hazard

- **Improper use** of the machine or failure to take the changes indicated in this manual into consideration may result in accidents causing damage not only to the machine itself, but also to objects and goods in its vicinity or mounted to the machine, as well as injuries to people in the immediate area, and possibly even death.
- Adhere to the **checklists** during all work activities: during preparation for the lifting operation, system construction, and for lifting the load. Failure to adhere to the checklists may result in serious injury to the user, possibly even death.
- Do not extend booms when a **person is close** to.
- **Local control** is only permitted if there is no header beam attached to the unit. A unit is only part of the central emergency stop system if the control selector switch is in the **remote position**.



Caution

- When lifting, always assume a **worst-case scenario**. The wind can be unpredictable, quickly changing speed and direction. Do not take any chances: if the wind is strong, that means it's a 'no go'!
- Never **extend or lower booms** to which something is attached since the extension cylinders are not designed to bear additional weight.



NB

Follow the instructions on labels applied to the system, without question.



Hazard

Despite all inherent safe design measures, safeguarding and complementary protective measures, there will always be the **residual risk** of tumbling of the system.

7.2. Warning signs on the System





The following signs are applied to the system:

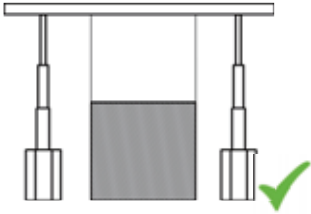
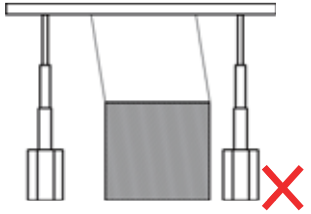

The legend of the symbols is given in section 2.3. "Symbols applied to the System".

7.3. Suspend the load

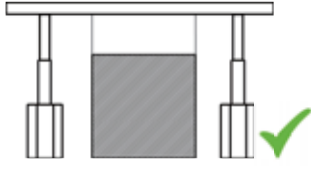
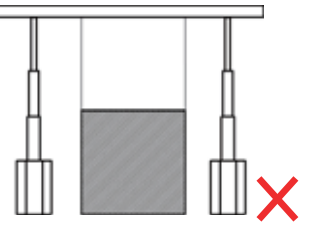
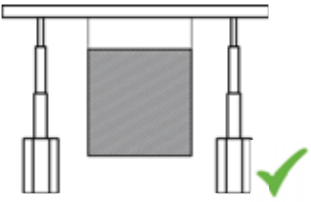
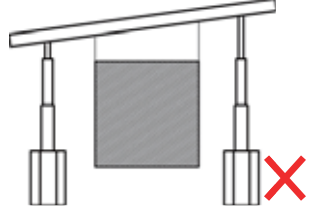
For suspending the load regard the following subjects:

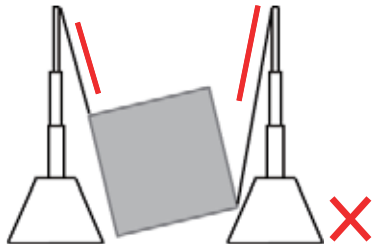
<p>1. The anchors on the header beam have to be in line with the hoisting points of the load.</p> <p> <i>Hazard: if the anchors are not in line with the hoisting points, the load will sway as soon as it gets free from the ground. The resulting lateral force may endanger the stability of the System.</i></p>	 <p>(front view) ✓</p>  <p>✗</p>
<p>2. Keep the lifting straps as short as possible.</p> <p> <i>Hazard: long slings may enable swinging of the load, causing dangerous lateral forces.</i></p>	 <p>(front view) ✓</p>  <p>✗</p>
<p>3. The header beam has to be kept level at any time, with a tolerance of 0.2°.</p> <p><i>Level the header beam at installation time. During operation the header beam is kept level automatically.</i></p>	 <p>(front view) ✓</p>  <p>✗</p>
<p>4. Lifting slings have to be plumb within a tolerance of 0.2°. This is especially applicable for tilting operations; see section 7.8. "Tilt the load".</p> <p> <i>Hazard: exceeding the limit of 0.2° will cause dangerous lateral forces.</i></p>	 <p>(side view) ✗</p>



7.4. Lift the load



This section describes how to lift the load.

In the procedure below reference is made to

- the controls on the RCC: “RCC [number of the control as given on page 81].
E.g. RCC[5] means: press the Speed button on the RCC.
- the Control Panels of the Units: “UNIT [the number of the control as given on page 79].

Proceed as follows:

1.	Record all activities during the operation using the form given in Appendix D “Recording a lifting operation”	
2.	Verify that the checklists given in: <ol style="list-style-type: none"> Appendix A Checklist for planning a lifting operation” Appendix B “Checklist for installing the System” Appendix C “Final checks “ are completed and signed off.	
3.	Switch the RCC on. <i>The RCC starts up.</i> <i>The software version number is displayed</i>	
4.	Verify the battery of the RCC is fully charged <i>The battery status is shown at the display.</i> <i>A full battery has a capacity of approximately 8 hours.</i>	
5.	Switch all four Units on. <i>Indicator UNIT [7] (power) lit .</i> <i>Indicators UNIT [8] and UNIT[8] (failure motor, side shift failure) should bedimmed</i>	
6.	Activate all four units.	
7.	Switch the units to Remote	

8.	<p>Reset the measured heights of all units by pressing “zero lift”.</p> <p><i>The current heights of the cylinders will be taken as the new reference points.</i></p> <p><i>The height counters [D] on the display will start counting from zero.</i></p>	
9.	<p>Select the travelling speed.</p> <p>Select “low” if the system is carrying a load.</p> <p><i>If the system detects a load or the units are extended for more than the first stage then “Low” is selected automatically.</i></p>	
10.	<p>Lift the load using RCC[7].</p> <p>While lifting, monitor the display (shown below).</p> <ul style="list-style-type: none"> • Monitor the lifting heights. <ul style="list-style-type: none"> The heights of the cylinders are measured continuously; see [A]. The RCC automatically levels the heights of the four cylinders within a bandwidth of 24 mm. <ul style="list-style-type: none"> ○ <i>When the height of one cylinder differs more than 12 mm from the others, its lifting speed (or the lifting speeds of the other beams) is slowed down until all heights are within a bandwidth of 6 mm.</i> ○ <i>When the difference of height exceeds 24 mm then system stops moving the load. Technical investigations of the problem have to be made. Follow the main problem solving procedure as described in 8.1. “Main problem localization procedure”.</i> • Monitor the individual loads on the units [E] • Monitor the total load on the system [B] • Monitor the direction of vertical movement [C] • Monitor the power status of the battery [F] 	
11.	Switch the unit off	
12.	Switch the RCC off	

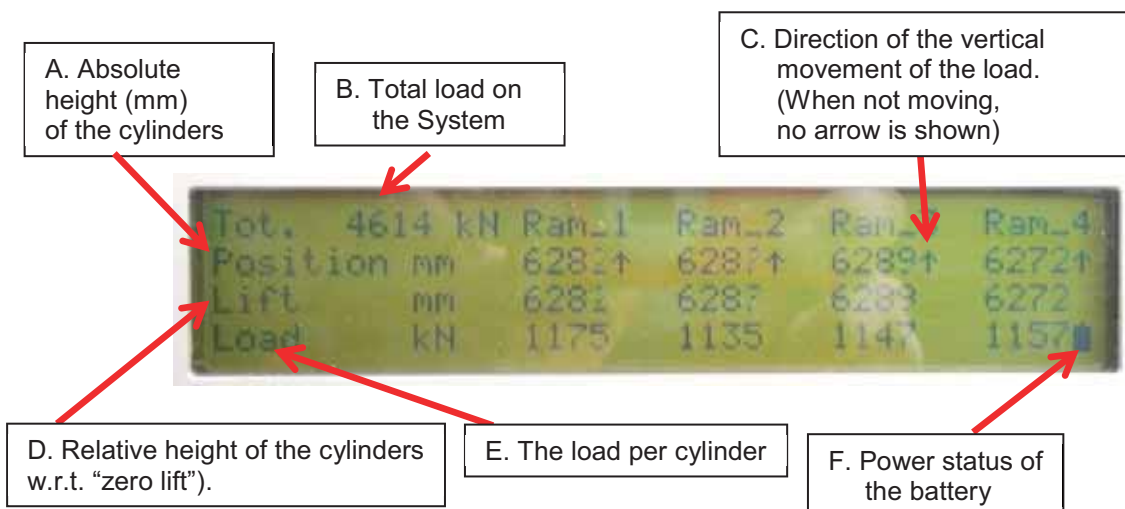



7.5. Move the load in longitudinal direction

- For travelling all four units simultaneously and synchronised, apply the RCC. See section 6.3.1 “The controls”.
- To move one single unit individually, you can use
 - local control; see section 6.2.2 “Local control mode”
 - the RCC; see section 6.3.1 “The controls”.

7.5.1. Move the units

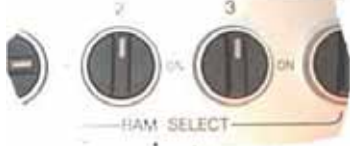
To move all units synchronously, proceed as follows:

1.	Apply the RCC; see page 82.	
2.	Verify that all checklists have been completed and signed off: <ul style="list-style-type: none"> • Appendix A Checklist for planning a lifting operation” • Appendix B “Checklist for installing the System” • Appendix C “Final checks “ 	
3.	Verify the power status of the battery of the RCC	
4.	Select the travelling speed [6]. Select “tortoise” if the system is carrying a load <i>If the system detects a load or the cylinders are extended for more than the first stage, tortoise is selected automatically.</i>	
5.	Enable all units; use the buttons [4] “Ram select”.	
6.	Use [8] “Travel” to move the units  Attention: When you have stopped the system four times then you have to synchronize the positions of the units. Synchronisation is described in the next section.	

7.5.2. Synchronize the positions of the units

The system keeps the relative positions of the units lined-up automatically. Use is made of a travelling distance measuring device which runs on the skid track.

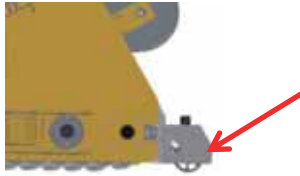

The measuring starts counting at zero every start. Due to the limited resolution of the measuring device, the positions of the units may get out of rectangular formation when the system has stopped moving several times.

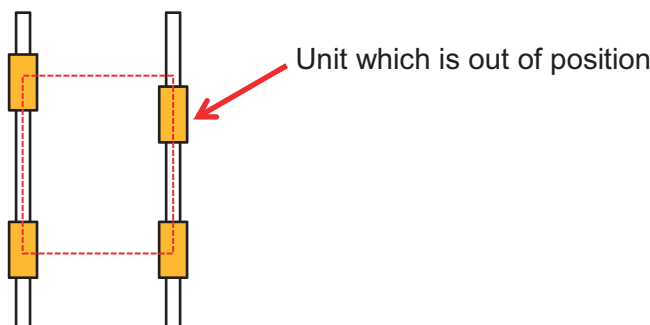



The following procedure can be applied to synchronise the positions of the units.

<p>1.</p>	<p>The units are in rectangular formation if</p> <ul style="list-style-type: none"> • $B1 = B2$ • $A1 = A2$. <p>To measure the positions of the units you might apply</p> <ul style="list-style-type: none"> • a tape-measure • optical measuring means, if you want to stay away from the System while it is bearing a load <p>Feel free to apply your own measuring methods.</p>	
<p>2.</p>	<p>If you detect misalignment then move the concerned unit (or units) to restore the rectangular formation. Apply local control or remote control to move the unit.</p> <p> Attention: To prevent worsening the situation:</p> <ul style="list-style-type: none"> • make sure you move the correct Unit(s) • make sure you move it in the correct direction <p>The stability of the system is at stake!</p>	

7.7. Move the load in transversal direction

For moving the load in transversal direction the moving capability of the side shift is applied.

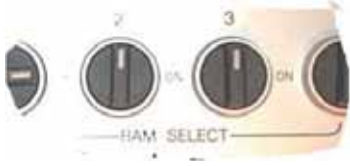
To operate the side shifts simultaneously, proceed as follows:

1.	Apply the RCC	
2.	Verify that all checklists have been completed and signed off: <ul style="list-style-type: none"> • Appendix A "Checklist for planning a lifting operation" • Appendix B "Checklist for installing the System" • Appendix C "Final checks". 	
3.	Verify the power status of the battery [F]; see the figure below.	
4.	Enable all units; use the buttons [4] "Ram select".	
5.	Use [9] "side shift" to move the selected side shift units simultaneously.	

7.8. Tilt the load

It is possible to perform tilt operations with the System.



Note the following aspects:

- Unlike the normal lifting operations, here the slings should be kept as **long** as possible, to minimize lateral forces.
- Always apply **four units**.
- Only move **two units at a time**.
The other two units are kept passive.
In the illustration above the red unit is the active one: it moves towards the blue unit.
The blue unit is passive and stands still.



Hazard: This operation has an increased risk of dangerous lateral forces.



If you want to perform a tilting operation, first contact Enerpac.

An illustrative video of a tilting operation is available on

<https://www.youtube.com/watch?v=rC1toW6ECfU>.

To tilt a load, proceed as follows.

In the procedure below, the controls of the RCC are indicated like “[x]”.
For the layout of those controls see page 81.

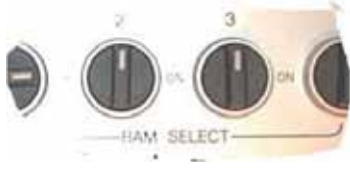
1.	Apply the RCC
2.	Record all activities during the operation using the form given in Appendix D “Recording a lifting operation”.
3.	Verify that all checklists have been completed and signed off: <ul style="list-style-type: none"> • Appendix A “Checklist for planning a lifting operation” • Appendix B “Checklist for installing the System” • Appendix C “Final checks”.
4.	Select the two ‘passive’ units on the RCC 
5.	Manoeuvre the header beam of the units attached to the (future) bottom of the load right above the load.
6.	Attach the bottom of the load to the header beam.
7.	De-select the passive units on the RCC
8.	Select the two ‘active’ units on the RCC
9.	Manoeuvre the header beam of the active units right upon the (future) top of the load.
10.	Attach the header beam to the load.
11.	Extend the cylinder for 5 cm.
12.	Let the units travel towards the passive units in such a way that the lifting eyes of the load are once again directly underneath the header beam.
13.	Verify that the lifting eyes are straight underneath the header beam with in tolerance of 0.2°. Use a plumb line, a laser or a theodolite.
14.	Repeat the steps 8 .. 10 until the load has been tilted completely.

8. Solve problems

This chapter describes localization and solving of problems.

- A main problem localization procedure is given.
- A list of possible problems is given, together with causes and possible solutions.

8.1. Main problem localization procedure

When during lifting or other use of the System problems occur, follow the steps below to solve the problem.

1.	Verify that no Emergency button is activated: <ul style="list-style-type: none"> • Is indicator [10] on the control panel lit? (Emergency active)
2.	Is there an overload problem? <ul style="list-style-type: none"> • Check the displayed Loads on the RCC [E] (see page 82). • Check the heights displayed on the RCC [A], [D] (see 82)
3.	Is there a technical problem in one of the units? Check the Control Panel of <u>all</u> units (see page 79): <ul style="list-style-type: none"> • indicator [7] should be lit (power on) • indicator [8] should be dimmed (motor failure) • indicator [9] should be dimmed (side shift overload)
4.	Are hydraulic leakages visible?
5.	Are there any mechanical obstructions ?
6.	Solve the problem accordingly. Call Enerpac if you need assistance

8.2. List of problems and solutions

The table below lists a number of errors and problems which may appear during the use of the System, together with possible causes and solutions.

Symptom	Possible cause	What to do...
Main problems		
Load value “-300” displayed <i>(large negative)</i>	Faulty or loose wiring	Check the wiring Call Enerpac
All units selected, but none moves up	Cylinder at end position?	-
	One of the hydraulic motors stopped	Press the START button [10] on the Control Panel to restart
	Emergency pressed?	Reset the Emergency
All units selected, but only one moves up	Height measurement was not zeroed.	Zero the height measurements using [10] of the RCC.
After switching on the Control Panel of a Unit, the error “communication timeout” is displayed on the RCC	This is normal behaviour due to time needed by the starting-up processes.	Wait for approximately 30 seconds
No display indication after switching on the RCC	Battery is low	Charge the battery for at least 4 hours
Reports on the display of the RCC		
“Emergency pressed”	An Emergency button was pressed, either on one of the unit or on the RCC.	Reset the emergency
“Communication timeout”	Radio disturbed	Use cable connection
“**” visible behind the RAMs”	No problem	Appears when the cable connection is used
“System not ready”	Initiation message	Wait a 20 seconds
“Stroke measurement out of range”	Measurement counter defect	Replace the device
	Fault in the wiring	Repair the wiring
	Height measurement cable snapped	Check the cable
“Load measurements out of range”	Sensor defect	Replace the sensor or contact Enerpac.
	Fault in the wiring	Check the wiring
“Drive sensor error” <i>(All Units stop driving)</i>	One of the travelling distance measuring devices defect	Change the sensor or contact Enerpac.  <i>If you do not have a spare sensor, you might remove all driving sensors of all Units. The System will be operational again, BUT WITHOUT DRIVING SAFETY! IT IS ON YOUR OWN RISK.</i>
	Too long misalignment between the Units	The sensor itself slips.
		One of the Units is obstructed
“Engine still”	Electro motor of the indicated unit is not running	Push [4] on the Control Panel of the Unit

Symptom	Possible cause	What to do...
"Overload"	Too much weight on one of the booms	If on one boom: the load is not divided properly over the System. Else: reconsider your lifting operation w.r.t. the weight of the Load
Mechanical and electrical problems		
The System does not travel	The two Bolts of the driving motors of the Units are loose	Fasten the bolts
	One of the hydraulic valves is defect	Repair the valve; Contact Enerpac.
The System does not lift	Hydraulic valve defect	Call Enerpac
	unit is switches off	Use [4] to switch the unit on
The cylinders raise unequally	Problem with oil flow or leakage.	Contact Enerpac
The System cannot lower the load	Problem with oil flow or leakage.	Contact Enerpac
The Side Shift does not move	Side shift not connected	Connect the Side Shift
	Thermic safety relays has tripped	Open the Electrical Cabinet and reset the relays indicated with 10QF2. See the picture below. If not successful then Contact Enerpac.
Indicator "Invertor Failure" on the Electrical Cabinet is lit		Try to start the motor, use [4] If not successful the open the Electrical Cabinet and reset the relays indicated with 11QF2; see the figure below. If not successful then Contact Enerpac.
Indicator "Side Shift Overload" on the Electrical Cabinet is lit		Try to start the motor, use [4] If not successful the open the Electrical Cabinet and reset the relays indicated with 10QF2; see the figure below. If not successful then Contact Enerpac.



The table is meant as a first aid kit. Contact Enerpac if you need assistance.



Hazard:
Performing repairs on the System may cause dangerous effects when not executed by well-skilled personnel.

9. Storage

Requirements for storage of the System:

- During short-term storage, especially in the open air, cover the units with a tarpaulin in order keep electrical and other moisture-sensitive components dry.
The tarpaulin is not included in the delivery, but can be added as an option.
- Long-term storage:
For long-term storage a dry and closed space is recommended.

Make sure the electrics are kept dry. Pay special attention to

- the stroke sensor and the
- travelling distance measuring device

since they are vulnerable parts.

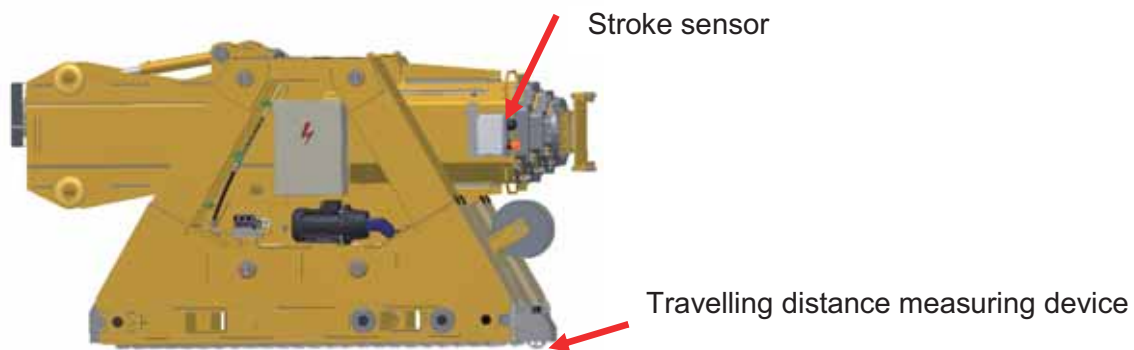

10. Maintenance

Keep the machine in good condition

- to obtain optimum performance from your machine
- to guarantee the safety of the users, it is important to.

This chapter describes

- the maintenance **jobs** to be carried out
- the required **skills** for the maintenance jobs
- the **time-intervals** the jobs have to be performed.

The intervals are based on **regular use** of the System; which is approximately one lifting operation per month. When the System is intensively or less intensively used, the maintenance intervals will change accordingly.



- Only perform maintenance on the units if they are not under load
- Only perform maintenance on the units if no header beams are mounted
- Maintenance which is not described in this section can only be performed by or in consultation with Enerpac.
- Only apply spare parts provided by Enerpac. If parts of foreign make are applied, all guarantees will be void.

10.1. Mechanical

Perform maintenance on the mechanical part according to the list as shown below.
Record all activities in Appendix E “Recording maintenance”.

Subject	Action	Person O (owner) EE (Enerpac expert)	First 40 hours	8 hours Daily	40 hours Weekly	Each 500 hours Each year	2000 hours Every 2 years	10000 hours Every 10 year	Remarks
1. Main construction									
1.1. Main construction	Visual check of all weldings	O				X			
	Visual check painting	O				X			
	Visual check on corrosion and damages	O			X				
	Check all bolts.	O				X			
	Visual check of the lifting lugs	O				X			
	Inspect the readability of the warning signs. Clean if obscured by dirt. Restore if damaged or even no longer present	O		X					
1.2. Test the oil of the gearboxes	Test the oil of the gearboxes; <i>see section 10.1.5 “Replace the oil of the gearbox”</i>	O					X		
1.3. Replace the oil of the gearboxes	Test the oil of the gearboxes; <i>see section 10.1.5 “Replace the oil of the gearbox”</i>	O						X	
1.4. Adjust the guiding pads	Adjust the guiding pads; <i>see section 10.1.7 “Adjust the guiding pads”</i>	EE	X		X				
1.5. Lubricate the swivel	Lubricate the swivel; <i>see section 10.1.6 “Lubricate the swivel”</i>	O	X			X			
2. Chain of the units									
2.1. Lubricate the chain	Lubricate the driving chains <i>see section 10.1.1 “Lubricate the driving chains”</i>	O				X			



2.2. Tension the chain	Tension the driving chains <i>see section 10.1.2 "Tension the driving chains"</i>	O				X			
2.3. Tension the roller chains	Tension the roller chain <i>see section 10.1.3 "Tension the roller chains"</i>	O				X			
3. Side shift unit									
3.1. Lubricate the chain	Lubricate the chain <i>see section 10.1.4 "Lubricate the side shift units"</i>	O				X			
4. Booms / guiding pads									
4.1. Adjust the guiding pads	Adjust the guiding pads. <i>See section "エラー! 参照元が見つかりません。".</i>	O/EE	X			X			
4.2. Booms	Lubricate the booms on the running surface of the guide pads with synthetic motor oil for instance 10W40. <i>See section "Booms / guiding pads".</i>	O/EE		X			X		

10.1.1. Lubricate the driving chains

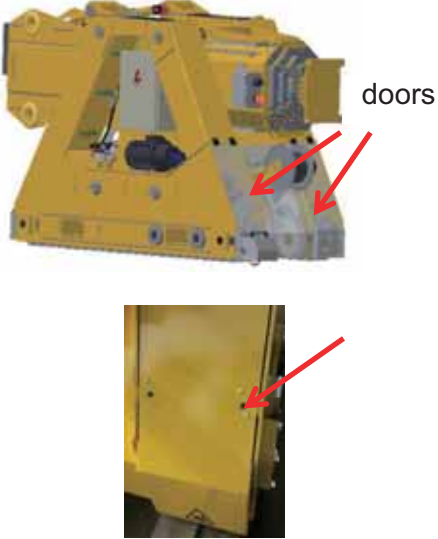
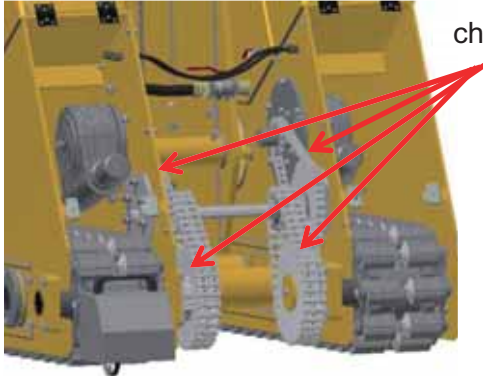
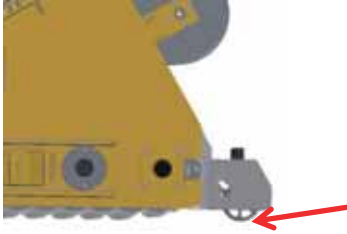
Chains connect the gearboxes with the driving shafts.
To lubricate the chains proceed as follows:

1.	Make sure the power supply has been switched of	
2.	Unlock the front doors and open them	
3.	Visually inspect the chains and the gears	
4.	Clean the chains	
5.	Lubricate the chain with Kroon Oil multi-purpose grease 3	
6.	Close the front doors and lock them	
7.	Verify that the wheel of the travelling distance measuring device runs fine	

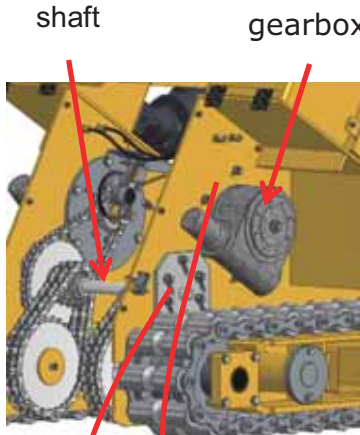
10.1.2. Tension the driving chains

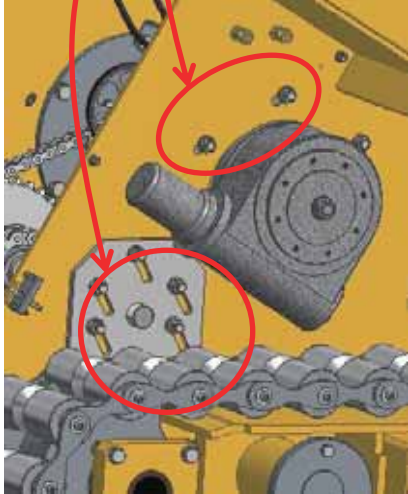
1.	Perform steps [1] .. [3] from section 10.1.1 "Lubricate the driving chains".	
	<ul style="list-style-type: none"> The gearbox is affixed to the frame of the unit with 6 bolts which can move in slotted holes. The bearings of the intermediate shaft are affixed to the frame of the unit with 6 bolts, which can move in slotted holes 	 <p>shaft gearbox</p>
2.	Loosen the bolts of the shaft	
3.	Tension the lower chain. The slack in the middle of the chain shall be 10 mm. Use hand power.	
4.	Tighten the bolts of the shaft	
5.	Loosen the bolts of the gearbox	
6.	Tension the upper chain until the slack is 10 mm in the middle of the chain. Use hand power.	
7.	<p>Tighten the bolts of the gearbox</p>  <p>Caution: tensioning the chains too tight might harm the driving mechanism</p>	
8.	Close the front door	





10.1.3. Tension the roller chains

To tension the roller chains proceed as follows:

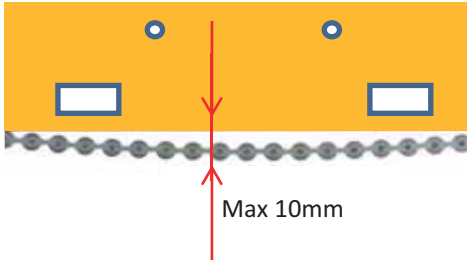
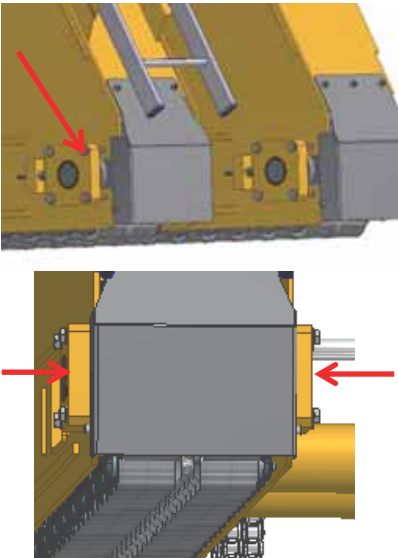

Hazard
During the adjustment, you are underneath the unit. Use lawful hoisting and lifting equipment.

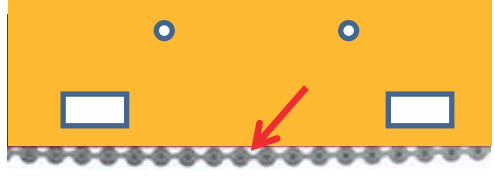
1.	Make sure the power supply has been switched of	
2.	Lift the unit.	
3.	<p>Verify the slack between the upside of the middle roller and the frame of the unit.</p> <p><i>If the clearance exceeds 10 mm then continue with the next steps.</i></p>	 <p>Max 10mm</p>
4.	<p>Unscrew the four bolts [1] at the rear side of the unit (so the side of the stairs) ...</p> <p>... both at the left- and the right hand side of the track. So, eight bolts in total.</p>	

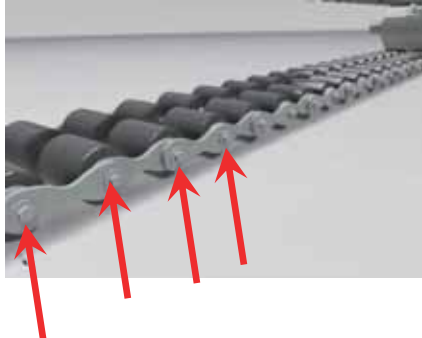
<p>5.</p>	<p>Tension the chains by turning the bolts. Use hand power. Make sure the shaft is kept parallel.</p> <p>Carry on turning until the top of the roll is flush with the frame</p> <p> Caution Tensioning the chain too tight might harm the driving mechanism</p>	 
<p>6.</p>	<p>Tighten the bolts.</p>	
<p>7.</p>	<p>Inspect the roller chain:</p> <ul style="list-style-type: none"> • Check he bolts on damage • Make sure the bolts of the chain are tightened (45 Nm) 	

10.1.4. Lubricate the side shift units

Clean the chains of the side shift units, and lubricate them.
Use "Kroon Oil multi-purpose grease 3". This is valid for both types of side shift units.

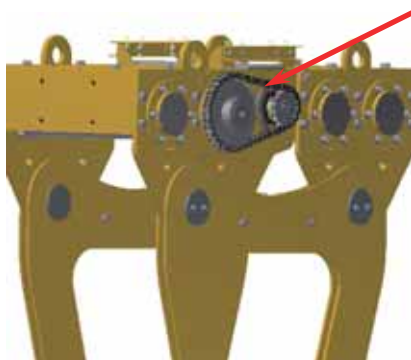

(The bearings of the side shift units were greased for lifetime.)

10.1.5. Replace the oil of the gearbox

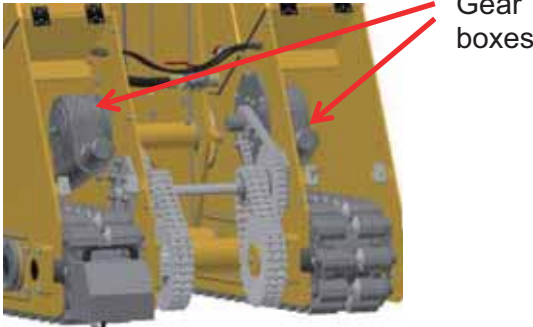
1.	Perform a purity test on the oil of the gearboxes	
2.	Change the oil of the gearbox <ul style="list-style-type: none">• If the yearly purity test points out, or• at least every 10 years Use 2.6 litres of oil type "ISO VG 320 Mineral oil".	

10.1.6. Lubricate the swivel

1.	Lubricate the nipples of the swivel; two at both sides.	
----	---	--

10.1.7. Adjust the guiding pads

The guiding pads of the booms have to be adjusted

- periodically, due to wear
- after replacement

The guiding pads are located in the booms on each stage →, so for the SBL100 on three spots, for the SBL900 on two spots.

At each stage, the inner side of the boom is provided with four sets of steel plates on which guiding pads are mounted:

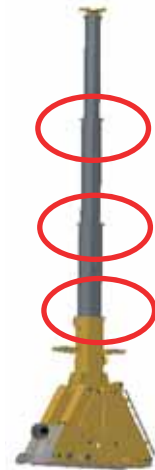
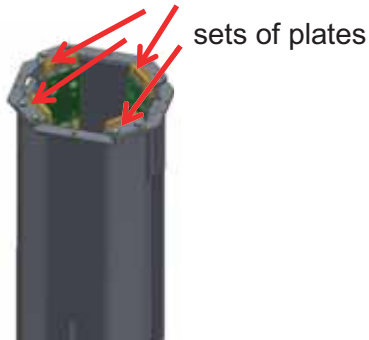

One set of steel plates consists of a two plates which abut against each other.

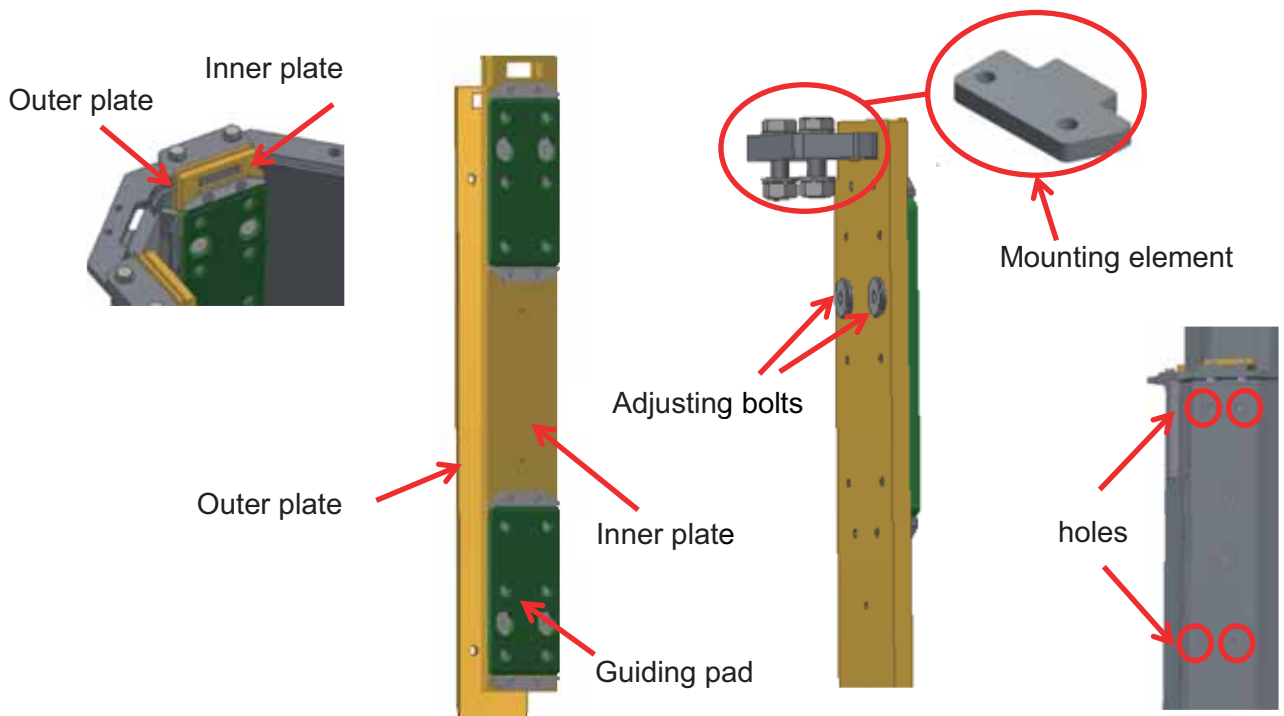

- Two guiding pads are mounted on the inner plate: one on the top and one on the bottom.
- The distance between the inner- and the outer plate can be adjusted by adjusting bolts. Those bolts can be reached through holes in the boom.
- The plates are affixed to the boom by a mounting element.



Adjusting the guiding pads is done stage by stage, by tensioning the adjusting bolts. The procedure has to be executed preferably by two persons.

 This accurate job should preferably be executed by Enerpac people.

To adjust the guiding pads proceed as follows:

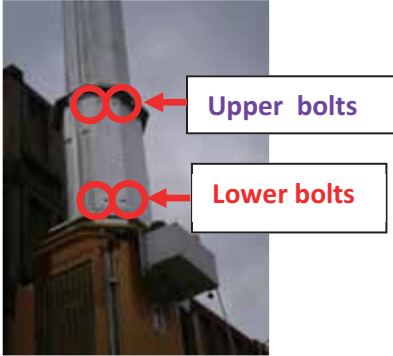
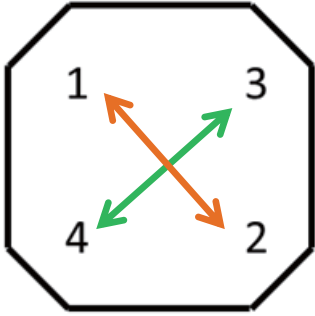
<p>1. Position yourself close to top of the unit. Use the platforms or your own means.</p> <div style="display: flex; align-items: center;">  <p>Hazard Wear a safety harness. You're working at height.</p> </div>	
<p>2. Extend the boom until the four holes for the upper bolts and the lower bolts are visible</p> <p>3. The adjusting bolts of the guiding pads are located behind the holes in the boom.</p> <p>Loosen the 8 upper bolts and the 8 lower bolts of the four sides by turning them clockwise. Turn them as far as possible.</p>	
<p>4. Turn only a half turn counter clockwise:</p> <ol style="list-style-type: none"> 1. the two upper bolts of side one 2. the two upper bolts of side two 3. the two upper bolts of side three 4. the two upper bolts of side four <p>Use little force. Turn the bolts simultaneously. (Therefore, two persons are required.)</p>	 <p style="text-align: center;">(top view)</p>
<p>5. Repeat step [4] until 100 Nm is reached</p>	
<p>6. Turn only a half turn counter clockwise:</p> <ol style="list-style-type: none"> 1. the two lower bolts of side one 2. the two lower bolts of side two 3. the two lower bolts of side three 4. the two lower bolts of side four 	
<p>7. Repeat step [6] until 100 Nm is reached <i>The inner beam is now centred inside the outer beam without being clamped</i></p>	
<p>8. Extend the boom until the four holes of the next section are visible</p>	
<p>9. Repeat the steps [2] .. [8] for the new stages</p>	

10.1.8. Booms / Guiding pads

Procedure:

- Saturate a rag and lubricate the booms on their running surfaces (mating surface of the guide pads) with synthetic motor oil for instance 10W40.

Remarks:

- In case of vibration of the booms during operation, execute this procedure also.
- In case of contamination of the running surface(s) by for instance sand, clean the running surfaces and lubricate the booms again.

In case of new guiding pads, execute this procedure also. But before installing the new pads, make sure to 'activate' the pads by rubbing them with a rag saturated with synthetic oil too.

10.2. Hydraulic

- All inspections up to yearly have to be performed if the system has been idle for at least 12 months.
- For repairs reference is made to section 2.6. “Working on the hydraulic system”.
- The system shall only be returned to service when approved by a qualified person as described that section.
- All replacement parts including the ram, hoses, couplings, seals, valves, and caps shall meet or exceed the original equipment manufacturer's specifications.

Hydraulic jacks shall be removed from service if damage such as the following is present:

- a) excessively worn, scored, cracked, bent, or broken ram
- b) cracked or broken jack housing or cylinder
- c) internal or external hydraulic fluid leak
- d) damaged seals or valves
- e) excessive pitting or corrosion
- f) excessive nicks or gouges
- g) missing or illegible identification
- h) indications of structural damage due to heat, or evidence of unauthorized welding
- i) improperly functioning or damaged load cap or integral auxiliary load point
- j) loose structural bolts or rivets
- k) worn or damaged load-bearing threads
- l) damaged or improperly assembled accessory equipment
- m) missing relief valve for double-acting jack
- n) damaged or severely worn hoses or couplings
- o) contaminated hydraulic fluid
- p) other conditions including visible damage that cause doubt as to the continued use of the hydraulic jack



Enerpac strongly advises to apply parts as bought from Enerpac.



Hazard

Applying parts which do not apply to the specifications may cause **hazards to personnel** and the system

Perform maintenance on the mechanical part according to the list as shown below.
 Record all activities in Appendix E “Recording maintenance”.
 For hydraulic fluid safety information sheet, see Appendix J “Hydraulic fluid safety information”.

Subject	Action	Person O (Owner) EE (Enerpac expert)	First	8 hours	40 hours	500 hours	2000 hours	10000 hours	Remarks
			40 hours	Daily	Weekly	yearly	2 years	10 years	
1. Electro motor, tank and cooler									
1.1. Motor	Check on oil leakage, damages and paint work	O		x					
	Check if the bolts are still tightened	O	x			x			
	Check on damages			x					
	Wipe it clean and free from dust			x					
1.2. Hydraulic tank	Check on oil leakage, damages and paint work	O		x					
	Check if the bolts are still tightened	O	x			x			
	Replace all seals	EE						x	
	Replace the level gauges	EE						x	
	Drain the tank (water and sludge)	EE					x		
1.3. Valves	Exchange the filler cap (which contains a filter)	O				x		x	
	Check on oil leakage and damages	O		x					
	Check if the bolts are still tightened	O	x			x			
	Replace all seals	EE						x	
1.4. Manifolds	Check all valve settings	O					x		
	Check on oil leakage and damages	O		x					
	Check if the bolts are still tightened	O				x			

1.5. Oil	Take an oil sample to analyze	EE				x		Change oil if necessary
	Replace the hydraulic oil. See section 10.2.1 "Drain the oil" and Section 10.2.2 "Filling the tank"	EE				x		Or after 2000 running hours
	Check the oil level	O		x				
1.6. Hydraulic filter	Check and replace the filter element. See section 10.2.3 "Replace the filter element".	EE			x		x	And if indicated by the clogging indicator
	Replace the seals of the filter housing	EE					x	
1.7. Breathers	Replace the breather	EE			x			
1.8. Bellhousing	Check on damages	O				x		
	Check if the bolts are still tightened	O	x				x	
	Replace motor pump coupling	EE					x	
1.9. Cooler	Check on oil leakage and damages	O		x				
	Check if the bolts are still tightened	O	x			x		
	Clean the cooler	O				x		
	Measure pressure difference "delta p" at the cooler	EE					x	
2. Hydraulic connections								
2.1. Pipes, hoses and brackets	Check on oil leakage and damages	O		x				
	Check if the couplings are tightened well.	O	x			x		
	Replace all seals within the piping (Waldform)	EE					x	
	Replace all hoses	EE					x	
	Replace all plastic brackets	EE					x	
2.2. Couplings and quick-screw couplings	Check on oil leakage and damages	O		x				
	Check if the couplings are tightened well.	O		x		x		
	Replace all seals of the couplings	EE					x	
	Replace fast couplings and screw couplings	EE					x	
2.3. Gauges, measurement sensors	Check on damages	O		x				
	Check the tightening bolts, nuts and components	O		x		x		
	Replace all seals	EE					x	
	Replace all gauges	EE					x	

3. Housing

3.1. Common	Check on damages and paint	O		x				
	Check if the bolts are still tightened	O	x			x		
	Replace all seals, door seals and inspection hatches	EE					x	
	Grease the hinges and locks	O				x		
	Replace engine feet	EE					x	



4. Cylinders

4.1. Common	Check on leakages	O		x				
	Check if the bolts are still tightened	O	x			x		
	Replace all seals	EE					x	
	Grease the bearings	EE			x			

10.2.1. Drain the oil

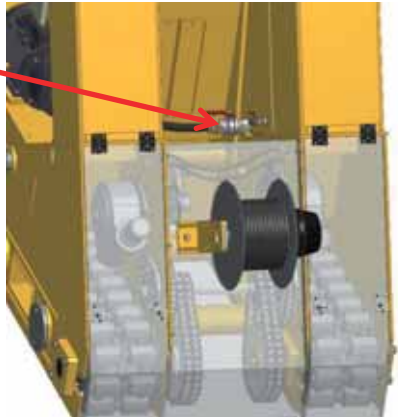
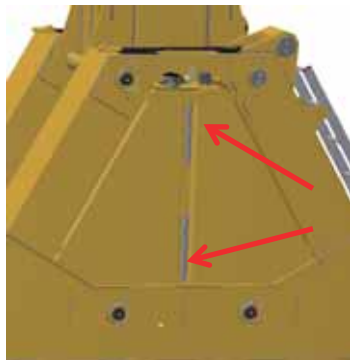

The oil in the sump has either to be refreshed or a purity test has to be performed. The minimum requirement is that the purity of the medium is in accordance with class 7 of NAS 1638.

Proceed as follows:

1.	Ensure that the cylinder is completely pulled in	
2.	Disconnect the hose from to the ball valve	
3.	Connect your own hose to the ball valve	
4.	Drain the oil. While draining, keep an eye on the oil level gauges	
5.	 Attention Dispose the oil responsibly	

10.2.2. Filling the tank

To fill the tank, proceed as follows:

1. Make sure the cylinder of the unit is fully pulled in	
<p>2. Use the fill/bleed opening to fill the tank with oil. Use oil type "Shell Tellus T32 or Shell Tellus Artic".</p> <div style="display: flex; align-items: center;">  <p>Caution Do not fill the tank over the maximum.</p> </div>	<p style="text-align: center;">Filler cap</p> 
3. Make sure that the oil is free of air by circulating the oil through the system. Just start the System and let it run for 10 minutes.	

10.2.3. Replace the filter element

The return filter cleans the oil that flows back into the tank.
Due to contamination of the oil, the permeability of the filter will decrease, which causes a raise of the pressure of the return flow of the oil. The pressure is shown on the clogging indicator:



Clogging indicator

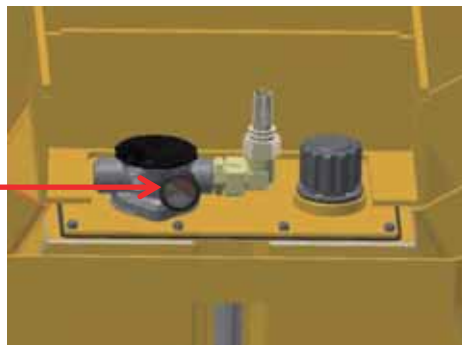

- Green: the pressure is 0 .. 2 bar
The filter is fine.
- Yellow: the pressure is 2..3 bar
The filter is still working, but has to be replaced as soon as possible.
- Red: the pressure is over 3 bar.
Oil is no longer filtered.
Replace the filter element immediately.

The filter element has to be replaced

- when the oil is refreshed
- when the clogging indicator shows yellow or red
- according to the maintenance scheme

To replace the filter element, proceed as follows:

1.	Unscrew the return filter cap
2.	Remove the internal filter element
3.	Put a new filter element. To ensure correct operation, only replace with an element with equal brand and type. Use <i>Hydac</i> return filters. The exact type is listed on the parts list of the machine.

10.3. Electrical

Perform maintenance on the electrics of the system according to the list below.
Record all activities in Appendix E “Recording maintenance”.

Subject	Action	Person O (owner) EE (Enerpac expert)	First 40 hours	8 hours	40 hours	Each 500 hours	2000 hours	10000 hours	Remarks
				Daily	Weekly	Each year	Every 2 years	Every 10 year	
1. Electro motor									
1.1. General	Check on damages	O		x					
	Wipe it clean and free from dust	O	x			x			
2. Cables and connectors									
2.1. General	Check on damages	O		x					
3. Devices and cabinets									
3.1. General	Check on damages	O		x				x	
	Check if the bolts and nuts are still tightened	O	x			x			
	Replace all seals	EE						x	
3.2. Main switch	Replace the main switch	EE						x	
3.3. Remote control	Replace the battery	O					x		

11. Quality

Not applicable

12. Recycling the machine

To recycle the machine at the end of its lifetime, proceed as follows:

- Drain and collect the hydraulic oil and other fluids separately, if applicable.
- Remove the batteries.
- Remove the electric components and electric wiring.
- Remove the metal components.

Separate all metals and liquids for recycling purposes and bring it to a recycling company.



Attention:
Dispose all material in a responsive way.

13. Index

A

accident, 16, 20, 35
accretion, 30
acid, 20
active, 74, 78, 95, 96,
97
address, 7, 87
adjustment, 8, 106
agent, 22
align, 66
allergic, 22
alterations, 8, 35
anchor, 50, 122
anchors, 89, 126
approval, 3, 8
aquatic, 22
assembling, 3
assistance, 21, 97,
99
attached, 26, 53, 63,
64, 71, 87, 96
authorized, 9
automatic, 30, 62

B

bandwidth, 91
batteries, 119
battery, 30, 76, 83,
84, 90, 91, 92, 94, 98,
118, 123, 131
beam, 25, 27, 33, 49,
50, 66, 67, 68, 69, 71,
87, 89, 96, 110, 122,
123, 126
beams, 25, 27, 28, 29,
31, 32, 33, 34, 36, 38,
41, 44, 48, 49, 50, 51,
53, 54, 67, 68, 71, 80,
91, 101, 123
bearing, 23, 31, 37,
38, 39, 40, 41, 42, 44,
45, 48, 49, 50, 51, 93
brackets, 29, 113,
130
breather, 113, 130

C

cable, 68, 70, 73, 98
cable-guiding, 68
cables, 19, 62, 64, 72,
74, 75, 124
calculate, 38, 41,
51
calculated, 37, 39,
42, 44, 51, 83
calculation, 37, 51,
52, 57
calculations, 7, 33, 51

calibrate, 85
calibration, 85
capability, 94
capacities, 31, 44
capacity, 23, 30, 36,
37, 39, 42, 44, 45, 48,
49, 50, 90, 122
carcinogen, 22
certificate, 19
certified, 9, 19, 23
chain, 68, 102, 103,
104, 105, 107, 129
chains, 102, 103, 104,
105, 106, 107, 129
charging, 30
chart, 45, 46, 47
checked, 23, 71
checklist, 23, 36,
39, 42, 44, 48, 50, 52,
77
checks, 90, 92, 94, 96,
125, 127
chemicals, 20
circulating, 116
clothing, 16, 20, 22
competent, 9, 19
configuration, 29,
31, 32, 33, 72, 76
console, 25, 29, 72,
81, 83, 84, 85, 131
contamination,
116
conventions, 3
cooler, 112, 113, 130
cordon, 19, 125
corrosion, 102, 129
corrosive, 20
cover, 3, 100
covering, 16
coverings, 16
crane, 53, 54, 56
cylinder, 26, 83, 86,
91, 96, 115, 116
cylinders, 25, 48,
63, 64, 65, 81, 82, 83,
85, 86, 87, 91, 92, 99

D

damage, 8, 14, 16, 19,
22, 23, 35, 53, 87,
107
damaged, 19, 102, 124,
125, 129
damages, 102, 112,
113, 114, 118, 129,
130, 131
dangerous, 89, 95,
99
deflections, 33
deleterious, 8

device, 19, 25, 26, 93,
98, 100, 104
dimensions, 27, 38,
40, 44, 52
direction, 8, 25, 28,
30, 31, 38, 48, 52, 61,
62, 68, 70, 80, 87, 91,
92, 93, 94, 122, 123
draining, 115
driving, 98, 99, 102,
103, 104, 105, 107,
123, 129

E

earth, 19
eccentric, 45
eccentricity, 45
education, 9
electric, 19, 25, 30,
63, 70, 119
electrical, 7, 9, 19, 20,
23, 25, 28, 62, 71, 99,
100, 124
electrician, 19
emergency, 20, 21,
74, 78, 83, 84, 87, 98
employee, 20
environment, 14, 19,
22
environmental, 44
environments, 8, 13
explode, 22
explosive, 8
extinguishing, 20
eye, 20, 22, 65, 115

F

failure, 14, 87, 90,
97
familiar, 21
filter, 112, 113, 116,
117, 130
filters, 117
flames, 22
flammable, 22
fluid, 19, 20, 21, 112
foot, 52, 65
footprint, 40, 41
footwear, 15
forklift, 53, 54, 56
fuses, 19

G

gauges, 112, 113, 130
gear, 15, 16, 104
gearbox, 102, 105,
108
gloves, 15, 22
goggles, 15

gravity, 35, 36, 63
grease, 104, 107, 149
grinding, 19
grooves, 61
ground, 16, 38, 39, 41,
42, 51, 56, 57, 89
guarantee, 3, 43,
101

H

handbook, 7, 31, 32,
33, 49
handheld, 15
hands, 17
harness, 15, 110
hazard, 22, 149
hazardous, 8, 20, 35
hazards, 8, 14, 21, 22
hose, 115
hoses, 19, 25, 113,
130
hydraulic, 16, 19,
23, 25, 48, 97, 98, 99,
111, 112, 113, 119,
124, 125, 130
hydraulically, 9,
25
hydraulics, 9, 19
hypersensitivity,
22

I

ice, 30
injure, 23
injured, 35
injuries, 16, 87
injury, 19, 22, 87
inspection, 19, 77,
114, 124, 131
install, 19, 53
installation, 8, 89
installing, 23, 77,
90, 92, 94, 96, 123,
125
insulated, 19

L

laser, 96
lateral, 89, 95
leakage, 99, 112, 113,
130
lean, 53
legal, 9, 16
legally, 21
legislations, 16
liability, 8
lifetime, 13, 107,
119

lift, 34, 45, 81, 83,
85, 90, 91, 99, 125
lifting, 3, 16, 23, 25,
26, 29, 31, 32, 34, 36,
39, 42, 44, 48, 50, 51,
52, 53, 54, 55, 56, 63,
81, 82, 87, 89, 90, 91,
92, 94, 95, 96, 97, 99,
101, 102, 106, 122,
123, 126, 127, 129,
138
limitations, 8
limits, 44, 45, 122
loading, 23, 30
lock, 30, 65, 104
locking, 23, 56, 67,
68
locks, 23, 114, 131
longitudinal, 8, 25,
33, 71, 92, 122
lubricate, 104, 107
lug, 31, 32, 138

M

maintain, 9
maintaining, 3
maintenance, 3, 9,
13, 16, 19, 22, 101,
102, 112, 116, 118,
129
manual, 3, 8, 14, 19,
21, 23, 87, 123
mass, 29, 38, 41, 48
measure, 93
measurement, 98,
113, 130
measures, 20, 22, 72,
85
motor, 28, 30, 85, 90,
97, 98, 99, 112, 113,
118, 130, 131
mouth, 20
moved, 23, 53
movement, 91
moves, 95, 98
moving, 3, 16, 17, 25,
26, 28, 31, 53, 61, 70,
81, 91, 93, 94

N

NEN-EN, 7
NEN-EN-ISO, 7

O

operate, 9, 57, 74, 82,
84, 94
operating, 15, 30
operation, 3, 35, 36,
38, 39, 41, 42, 44, 48,
50, 51, 52, 81, 87, 89,
90, 92, 94, 95, 96, 99,
101, 117, 122, 123,
127
operational, 98
operations, 35, 44,
45, 52, 80, 89, 95
operator, 9, 14, 16,
29, 80, 81
operators, 3, 8, 23
original, 8, 19

P

paint, 112, 114, 130,
131
people, 8, 15, 16, 35,
87, 110, 125, 149
permeability, 116
permissible, 51, 52,
122
persistent, 76
person, 9, 87
personal, 21, 22
planning, 36, 39, 42,
43, 44, 48, 50, 51, 52,
90, 92, 94, 96, 122,
123
plywood, 43
preparation, 53, 87
prepare, 36, 87
pressure, 19, 22, 27,
30, 36, 37, 38, 39, 41,
42, 65, 113, 116, 122,
130
pressurized, 19

protection, 21, 22,
23
protective, 15, 22

R

radio, 29, 72
railway, 27
recycling, 119

S

safe, 13, 19, 29, 81
safety, 3, 7, 8, 14, 15,
16, 19, 20, 21, 57, 87,
99, 101, 110, 112
secure, 23, 43
secured, 23, 43
securely, 71
sensor, 26, 71, 85, 86,
98, 100
setting, 68, 76, 80,
87
shackles, 16, 38, 41,
51
shaft, 63, 65, 105,
107
shims, 58, 60
side-load, 51, 125
smoke, 22
software, 90
stage, 20, 45, 79, 82,
91, 92, 109, 110, 122
subsoil, 27, 36, 37,
39, 42, 57, 122
substance, 20
subsurface, 16
supervision, 9, 19
synchronise, 26, 93
synchronously, 92

T

tank, 112, 113, 116,
130
tarpaulin, 100
temperature, 30
tension, 23, 106

tensioning, 105,
110
theodolite, 96
timbers, 23, 40, 41,
43, 55, 57, 58
torque, 53, 123, 149
tortoise, 92
toxic, 22
track, 25, 27, 38, 41,
60, 93, 106
tracks, 25, 27, 31, 32,
36, 37, 38, 40, 44, 54,
57, 58, 59, 60, 61,
123, 124, 125, 132
trained, 9, 19, 23
training, 9
transport, 23
transporting, 28,
35, 55
transversal, 25, 28,
70, 94, 122
transverse, 8, 48

U

USB, 7, 51

V

ventilate, 21
vicinity, 16, 35, 87
victim, 20
voltage, 7, 17, 19

W

wheel, 68, 104
wind, 36, 51, 52, 87,
122
wireless, 72, 75

Z

zero, 60, 83, 91, 93
zone, 19, 125

Appendices

A. Checklist for planning a lifting operation

1. Project

Project	
Customer	
Location	
Date	

2. Operation type

<input type="checkbox"/>	Lift / lower
<input type="checkbox"/>	Move in longitudinal direction
<input type="checkbox"/>	Move in transversal direction

3. Ground bearing pressure

<input type="checkbox"/>	Allowable ground bearing pressure (σ_{toe}) Tonne/_m ²
--------------------------	--	-----------------------------

4. Capacity

<input type="checkbox"/>	Mass of the load	
<input type="checkbox"/>	Lifting height mm
<input type="checkbox"/>	Stage of Extension	1 / 2
<input type="checkbox"/>	Capacity in highest stage kN
	Allowable load: kN
<input type="checkbox"/>	The mass of the load does not exceed the allowable load	
<input type="checkbox"/>	Minimum force per unit is sufficient kN
<input type="checkbox"/>	Maximum force per anchor point does not exceed the capacity of the side shift <i>(if applicable)</i> kN
<input type="checkbox"/>	The force on the applied header beam does not exceed the limits	
	Maximum permissible wind speed X-direction m/sec
	Y-direction m/sec
<input type="checkbox"/>	The side load does not exceed 1.5 % of the vertical load	

5. Commitment

Planning by:

Date:

Signature:

Approved by:

Date:

Signature:

B. Checklist for installing the System

1. Project

Project	
Customer	
Location	
Date	

2. Planning

<input type="checkbox"/>	Checklist A “Checklist for planning a lifting operation” was completed and signed off
--------------------------	---

3. Foundation

<input type="checkbox"/>	Foundation underneath skid tracks has been put in accordance with the instructions in this manual. <i>If foundation is applied</i>
--------------------------	--

4. Skid tracks

<input type="checkbox"/>	Skid tracks placed according to instructions in manual
<input type="checkbox"/>	Skid tracks connected according to instructions in manual.
<input type="checkbox"/>	Skid tracks aligned according to instructions in manual.

5. Units

<input type="checkbox"/>	Move all units forwards and backwards over a short distance using the RCC, to ensure you have set the positive driving direction correctly.
<input type="checkbox"/>	Slide all beams in and out over a short distance. <i>(This assures the communication functions properly.)</i>
<input type="checkbox"/>	Check the battery status of the RCC
<input type="checkbox"/>	The stroke sensors are undamaged

6. Header beam

<input type="checkbox"/>	Bolts on the swivel tightened to torque in accordance with instructions in manual
<input type="checkbox"/>	Beam is horizontal (level) on the two units

7. Side shifts

<input type="checkbox"/>	Side shift units mounted in accordance with instructions in manual
<input type="checkbox"/>	Move the side shift units to the right and the left over a short distance, to ensure you have set the positive driving direction correctly.

8. Visual inspection

<input type="checkbox"/>	Visual inspection: no excessive rust.
<input type="checkbox"/>	Visual inspection: no parts of the system are damaged
<input type="checkbox"/>	Visual inspection of the hydraulic components: no oil leakages
<input type="checkbox"/>	Running surfaces of the skid tracks are clean. <i>(Dirt may cause the units slip)</i>
<input type="checkbox"/>	The units can run freely and are not obstructed.
<input type="checkbox"/>	Inspection of the electrics: electrical cables are undamaged electrical cables cannot be pinched

9. Applied equipment

<i>What</i>	<i>Length</i>	<i>Capacity</i>	<i>Mass</i>
Lifting straps			
Chains			
Other			

10. Commitment

Installed by:

Date:

Signature:

Approved by:

Date:

Signature:

C. Final checks

1. Project

Project	
Customer	
Location	
Date	

2. Installation

<input type="checkbox"/>	Checklist B "Checklist for installing the System" was completed and signed off
--------------------------	--

3. Inspect the System

<input type="checkbox"/>	No parts of the portal lift are damaged
<input type="checkbox"/>	No leakages of the hydraulic components
<input type="checkbox"/>	Drop-zone is cordoned off. No people are inside the unsafe zone. Barriers and tape are used.
<input type="checkbox"/>	Running surfaces of the skid tracks are clean.
<input type="checkbox"/>	The units can run freely and are not obstructed.
<input type="checkbox"/>	The weight of the load is indicated on the RCC correctly.
<input type="checkbox"/>	The side-load does not exceed 1.5 % of the vertical load

Part 1/2

Part 2/2

4. Check the suspension of the load

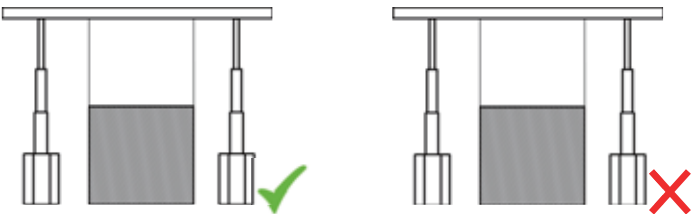
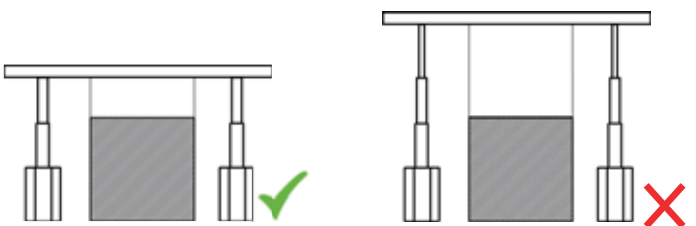
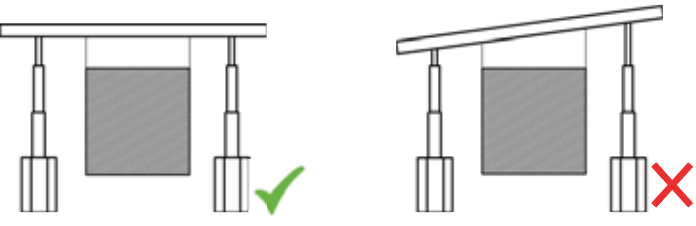
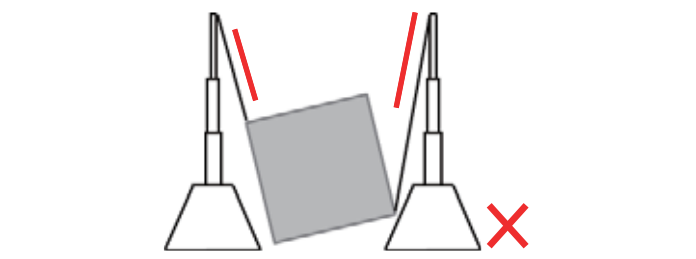
<input type="checkbox"/>	<p>The anchors on the header beam are in line with the hoisting points of the load.</p>	 <p>(front view)</p>
<input type="checkbox"/>	<p>The lifting straps are short.</p>	 <p>(front view)</p>
<input type="checkbox"/>	<p>The header beam are level</p>	 <p>(front view)</p>
<input type="checkbox"/>	<p>Lifting slings are plumb.</p>	 <p>(side view)</p>

5. Commitment

Inspected by:

Date:

Signature:

Approved by:

Date:

Signature:

D. Recording a lifting operation

1. Project

Project	
Customer	
Location	
Date	

2. Recording of activities

Activity		Time
<input type="checkbox"/>	The checklists have been completed and are signed off: Appendix C "Final checks" has been completed and signed off	
1		
2		
3		
4		
5		
6		
7		
8		

Part 2/3

Activity	Time
9	
10	
11	
12	
13	
15	
16	
17	
18	

3. Commitment

Executed by:

Date:

Signature:

Approved by:

Date:

Signature:

E. Recording maintenance

Use the table below for recording all maintenance activities, accordance with section 10. "Maintenance".

a. Mechanical:

Subject	Action	Person	Date
1. Main construction			
1.1. Main construction	Visual check of all weldings		
	Visual check painting		
	Visual check on corrosion and damages		
	Check all bolts.		
	Visual check of the lifting lugs Inspect the readability of the warning signs. Clean if obscured by dirt. Restore if damaged or even no longer present		
1.2. Test the oil of the gearboxes	Test the oil of the gearboxes		
1.3. Replace the oil of the gearboxes	Replace the oil of the gearboxes		
1.4. Adjust the guiding pads	Adjust the guiding pads		
2. Chain of the units			
2.1. Lubricate the chain	Lubricate the driving chains		
2.2. Tension the chain	Tension the driving chains		
2.3. Tension the roller chains	Tension the roller chains		
3. Side shift unit			
3.1. Lubricate the chain	Lubricate the chain		

b. Hydraulical:

Subject	Action	Person	Date
1. Electro motor, tank and cooler			
1.1. Motor	Check on oil leakage, damages and paint work		
	Check if the bolts are still tightened		
	Check on damages		
	Wipe it clean and free from dust		
1.2. Hydraulic tank	Check on oil leakage, damages and paint work		
	Check if the bolts are still tightened		
	Replace all seals		
	Replace the level gauges		
	Drain the tank (water and sludge)		
1.3. Valves	Exchange the filler cap (which contains a filter)		
	Check on oil leakage and damages		
	Check if the bolts are still tightened		
	Replace all seals		
1.4. Manifolds	Check all valve settings		
	Check on oil leakage and damages		
1.5. Oil	Check if the bolts are still tightened		
	Take an oil sample to analyze		
1.6. Hydraulic filter	Replace the hydraulic oil.		
	Check the oil level		
	Replace the filter element.		
1.7. Breathers	Replace the seals of the filter housing		
	Replace the breather		
1.8. Bellhousing	Check on damages		
	Check if the bolts are still tightened		
	Replace motor pump coupling		
1.9. Cooler	Replace motor pump coupling		
	Check on oil leakage and damages		
	Check if the bolts are still tightened		
	Clean the cooler		
2. Hydraulic connections	Measure pressure difference "delta p" at the cooler		
	2.1. Pipes, hoses and brackets		
	Check on oil leakage and damages		
	Check if the couplings are tightened well.		
2.2. Couplings and quick-screw couplings	Replace all seals within the piping (Waldform)		
	Replace all hoses		
	Replace all plastic brackets		
	Check on oil leakage and damages		
2.3. Gauges, measurement sensors	Check if the couplings are tightened well.		
	Replace all seals of the couplings		
	Replace fast couplings and screw couplings		
	Check on damages		
	Check the tightening bolts, nuts and components		
	Replace all seals		
	Replace all gauges		

3. Housing			
3.1. Common	Check on damages and paint		
	Check if the bolts are still tightened		
	Replace all seals, door seals and inspection hatches		
	Grease the hinges and locks		
	Replace engine feet		
4. Cylinders			
4.1. Common	Check on leakages		
	Check if the bolts are still tightened		
	Replace all seals		
	Grease the bearings		

c. Electric:

Subject	Action	Person	Date
1. Electro motor			
1.1. General	Check on damages		
	Wipe it clean and free from dust		
2. Cables and connectors			
2.1. General	Check on damages		
3. Devices and cabinets			
3.1. General	Check on damages		
	Check if the bolts and nuts are still tightened		
	Replace all seals		
3.2. Main switch	Replace the main switch		
3.3. Remote Control console	Replace the battery		

F. Drawings for the skid tracks

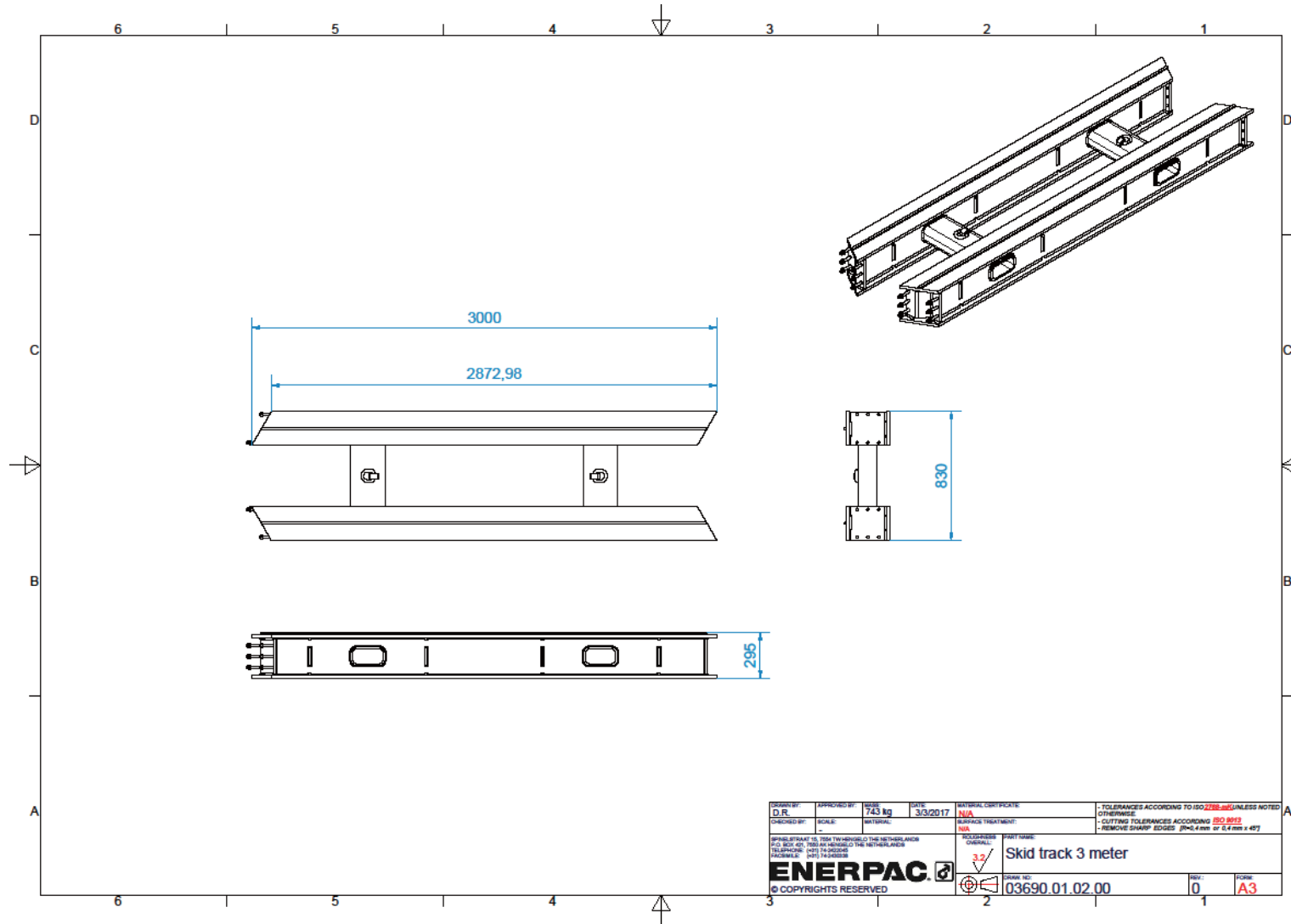

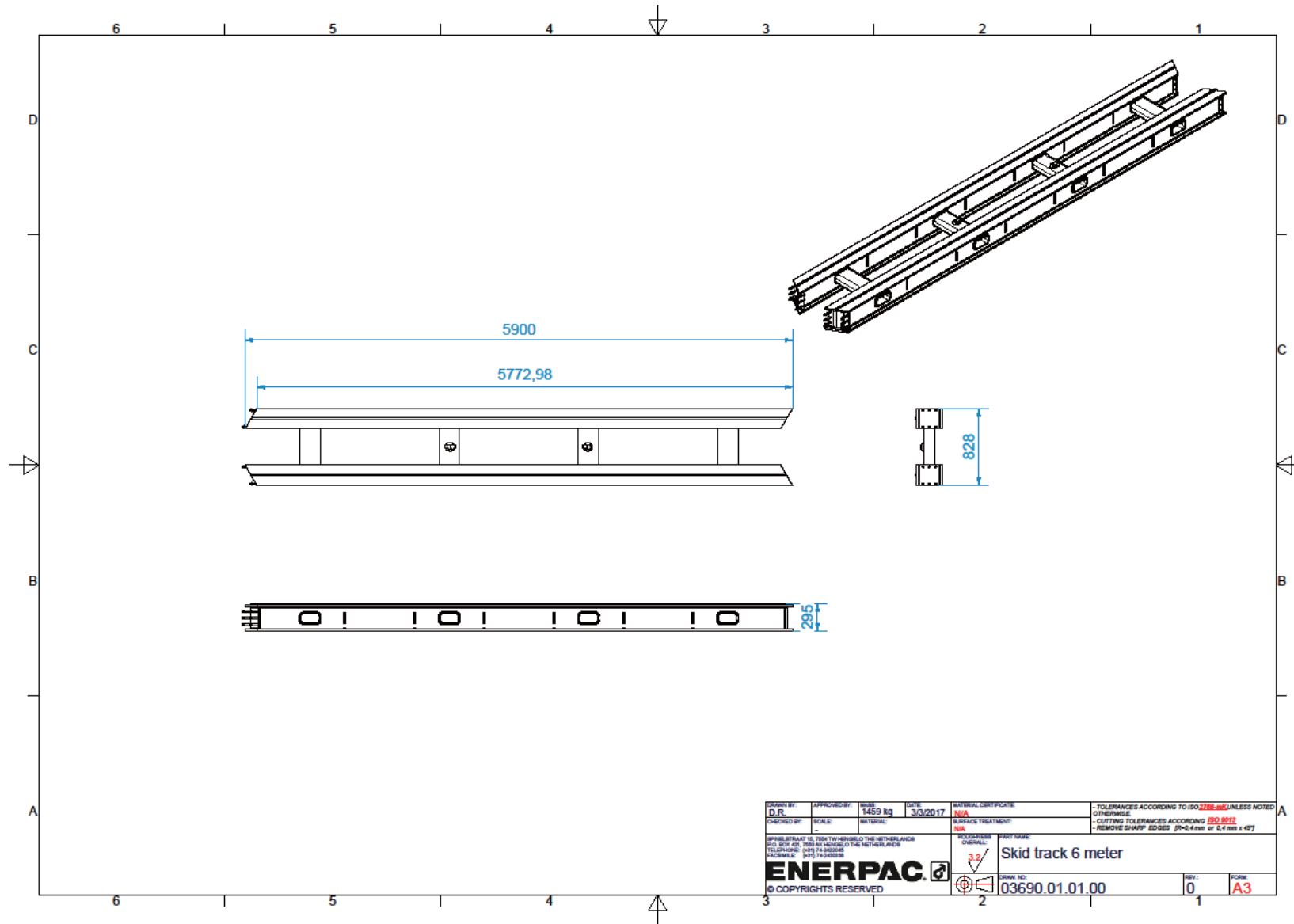

DESIGNED BY: D.R.	APPROVED BY:	WEIGHT: 1459 kg	DATE: 3/3/2017	MATERIAL CERTIFICATE: N/A	TOLERANCES ACCORDING TO ISO 2768- MS UNLESS NOTED OTHERWISE
CHECKED BY:	SCALE:	MATERIAL:	SURFACE TREATMENT: N/A	CUTTING TOLERANCES ACCORDING TO ISO 8013	REMOVE SHARP EDGES (R0.4 max or 0.4 mm x 45°)
SPANLEERIJ 15, 1504 TW-HENGELO THE NETHERLANDS P.O. BOX 421, 1900 AN HENGELO THE NETHERLANDS TELEPHONE: +31 (0) 74 3000000 TELEFAX: +31 (0) 74 3000000		SUSPENSION OVERALL: 		PART NAME: Skid track 6 meter	
ENERPAC © COPYRIGHTS RESERVED		DRAW NO: 03690.01.01.00		REV: 0	FORM: A3

G. Drawing of the units

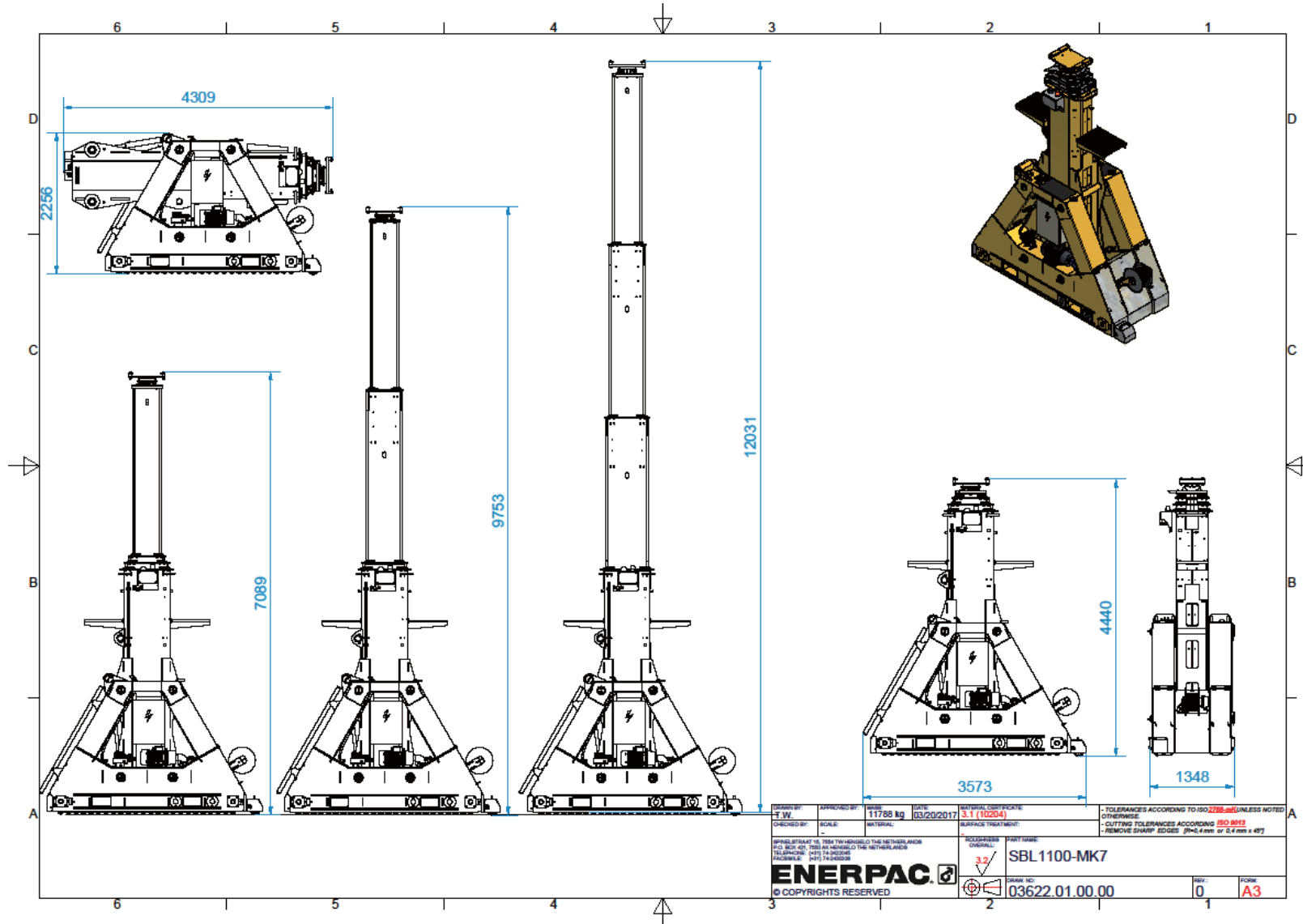

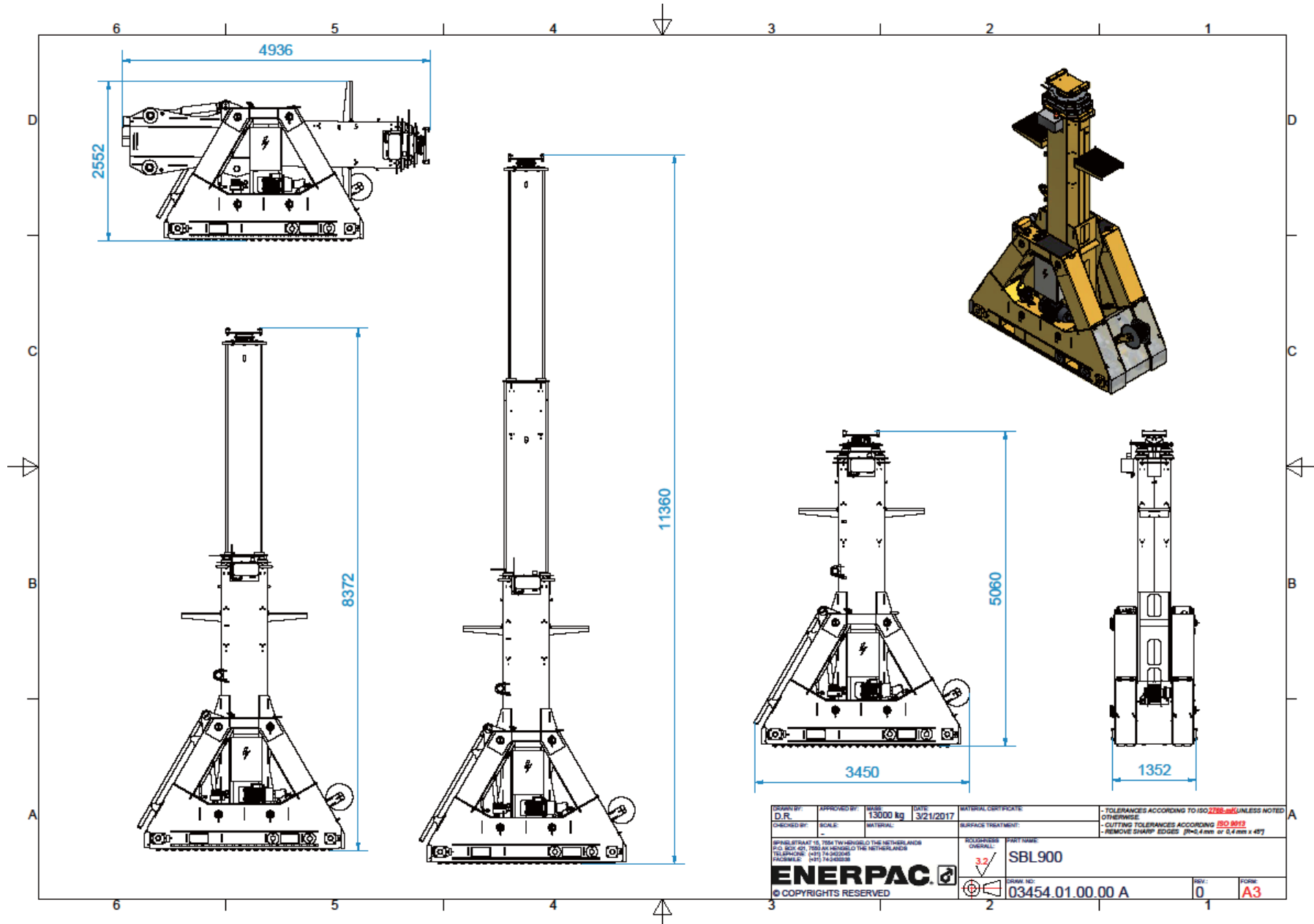

H. Drawings of the side shift units

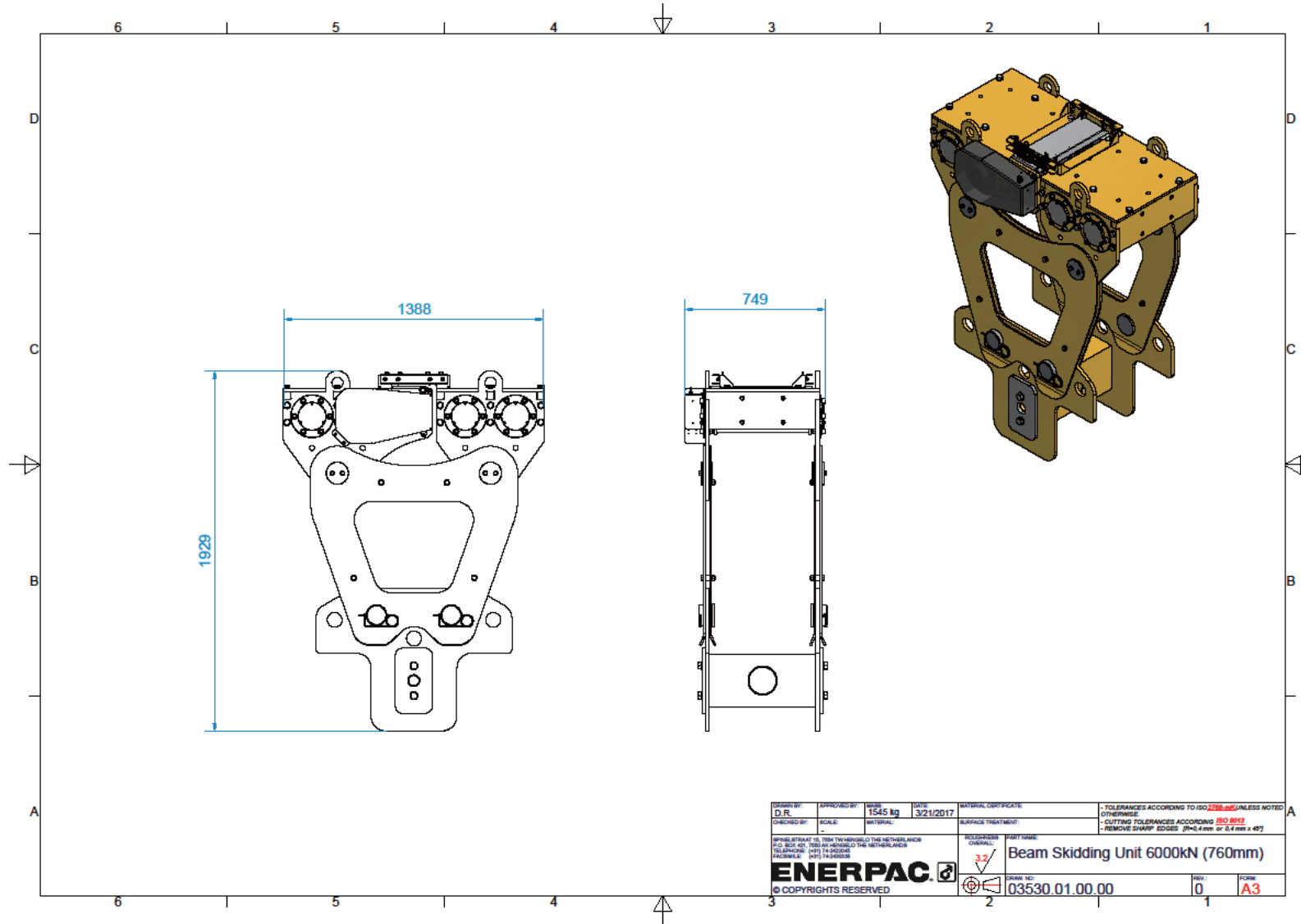

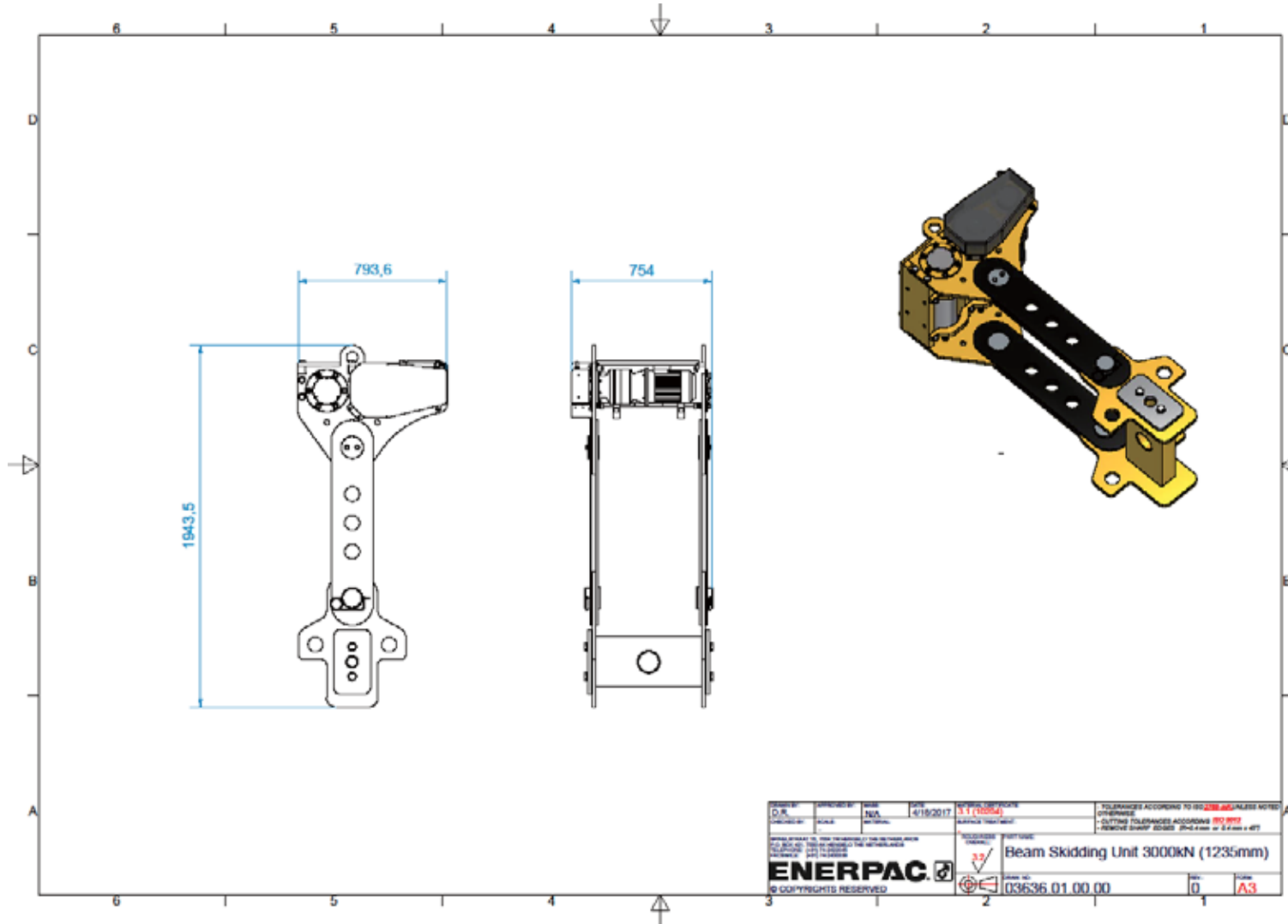

I. Drawings of the lifting lug

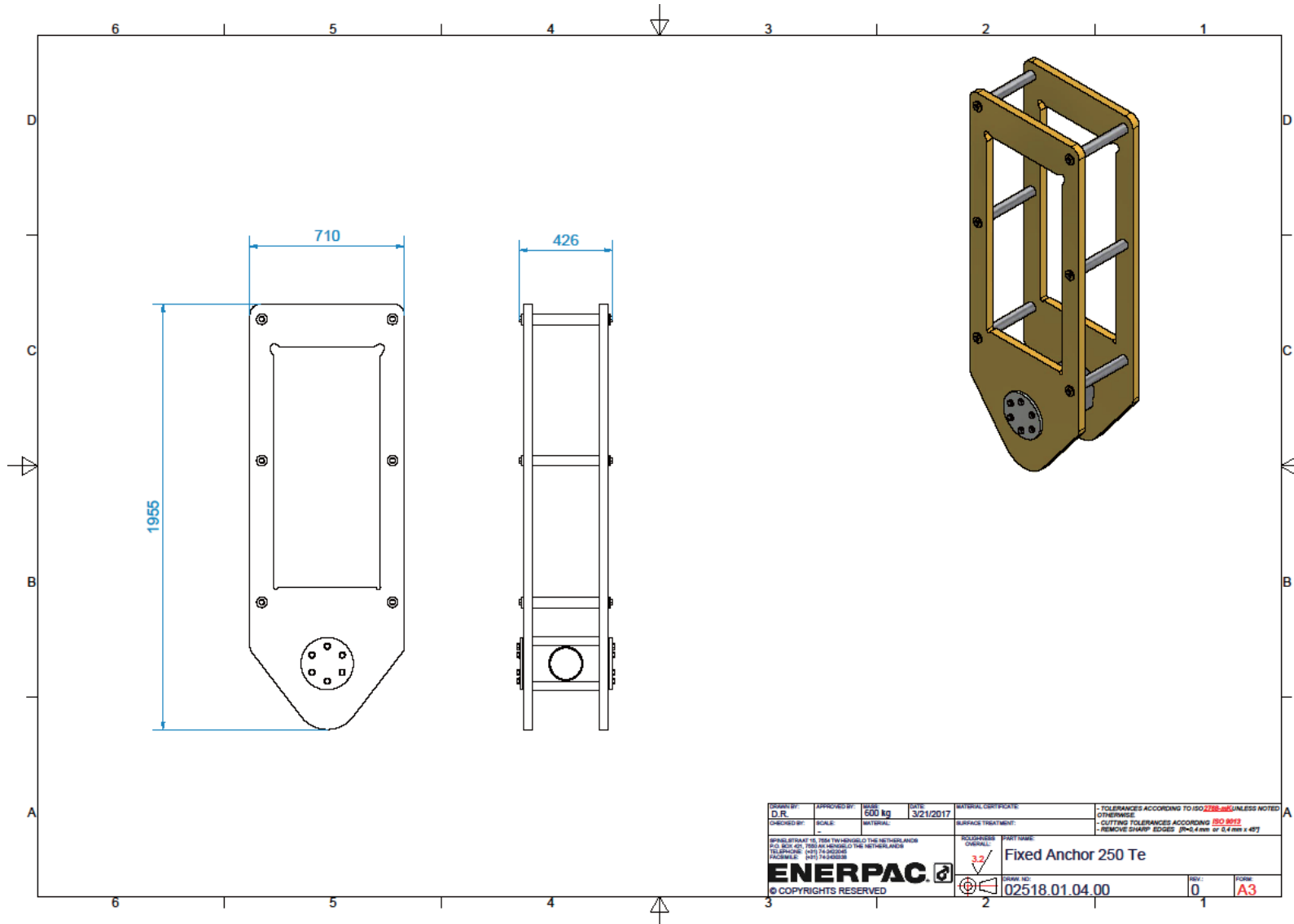

J. Hydraulic fluid safety information

HF-95 Hydraulic oil

Safety Data Sheet

according to Regulation (EC) No. 453/2010

Date of issue: 02/03/2004

Revision date: 10/02/2015

Supersedes: 24/02/2012

Version: 4.0

SECTION 1: Identification of the substance/mixture and of the company/undertaking

1.1. Product identifier

Product form	:	Mixture
Product name	:	HF-95 Hydraulic Oil
Product group	:	Blend

1.2. Relevant identified uses of the substance or mixture and uses advised against

1.2.1. Relevant identified uses

Main use category	:	Industrial use, Professional use, Consumer use
Industrial/Professional use spec.	:	Non-dispersive use Used in closed systems
Function or use category	:	Lubricants and additives

1.2.2. Uses advised against

No additional information available

1.3. Details of the supplier of the safety data sheet

Enerpac B.V.
P.O. Box 8097, 6710 AB EDE
THE NETHERLANDS
Tel: +31(0)318 535911

1.4. Emergency telephone number

Emergency number	:	0032 (70) 245 245
------------------	---	-------------------

SECTION 2: Hazards identification

2.1. Classification of the substance or mixture

Classification according to Regulation (EC) No. 1272/2008 [CLP]
Not classified

Classification according to Directive 67/548/EEC or 1999/45/EC
Not classified

Adverse physicochemical, human health and environmental effects
No additional information available

2.2. Label elements

Labelling according to Regulation (EC) No. 1272/2008 [CLP] EUH phrases	:	EUH210 - Safety data sheet available on request
---	---	---

2.3. Other hazards

No additional information available

SECTION 3: Composition/information on ingredients
3.1. Substances

Not applicable

3.2. Mixture

Name	Product identifier	%	Classification according to Directive 67/548/EEC
Baseoil - unspecified	(CAS No) 64742-55-8 (EC no) 265-158-7	1 - 25	Not classified
Zinkalkyldithiophosphate	(CAS No) 68649-42-3 (EC no) 272-028-3 (REACH-no) 01-2119493635-27	0,1 - 0,5	Xi; R41 Xi; R38 N; R51/53
2,6-Di-tert-butylphenol	(CAS No) 128-39-2 (EC no) 204-884-0	0,1 - 0,25	Xi; R38 N; R50/53

Name	Product identifier	%	Classification according to Regulation (EC) No. 1272/2008 [CLP]
Baseoil - unspecified	(CAS No) 64742-55-8 (EC no) 265-158-7	1 - 25	Asp. Tox. 1, H304
Zinkalkyldithiophosphate	(CAS No) 68649-42-3 (EC no) 272-028-3 (REACH-no) 01-2119493635-27	0,1 - 0,5	Eye Dam. 1, H318 Aquatic Chronic 2, H411
2,6-Di-tert-butylphenol	(CAS No) 128-39-2 (EC no) 204-884-0	0,1 - 0,25	Skin Irrit. 2, H315 Aquatic Acute 1, H400 Aquatic Chronic 1, H410

Full text of R-, H- and EUH-phrases: see section 16

SECTION 4: First aid measures
4.1. Description of first aid measures

First-aid measures after inhalation	:	Not expected to require first aid measures.
First-aid measures after skin contact	:	Wash skin with mild soap and water.
First-aid measures after eye contact	:	In case of eye contact, immediately rinse with clean water for 10-15 minutes.
First-aid measures after ingestion	:	Do not induce vomiting. Rinse mouth. Get immediate medical advice/attention.

4.2. Most important symptoms and effects, both acute and delayed

Symptoms/injuries after inhalation	:	Not expected to present a significant inhalation hazard under anticipated conditions of normal use.
Symptoms/injuries after skin contact	:	Not expected to present a significant skin hazard under anticipated conditions of normal use.
Symptoms/injuries after eye contact	:	Not expected to present a significant eye contact hazard under anticipated conditions of normal use.
Symptoms/injuries after ingestion	:	Not expected to present a significant ingestion hazard under anticipated conditions of normal use.

4.3. Indication of any immediate medical attention and special treatment needed

No additional information available

SECTION 5: Firefighting measures
5.1. Extinguishing media

Suitable extinguishing media	:	Water fog. Foam. Powder. Dry chemical product.
Unsuitable extinguishing media	:	Do not use a heavy water stream.

5.2. Special hazards arising from the substance or mixture

No additional information available

5.3. Advice for firefighters

Precautionary measures fire	:	Exercise caution when fighting any chemical fire.
Firefighting instructions	:	Use water spray or fog for cooling exposed containers.
Protection during firefighting	:	Do not enter fire area without proper protective equipment, including respiratory protection.

SECTION 6: Accidental release measures

6.1. Personal precautions, protective equipment and emergency procedures

6.1.1. For non-emergency personnel Protective equipment	:	Wear suitable protective clothing and gloves.
--	---	---

6.1.2. For emergency responders

Protective equipment	:	Wear suitable protective clothing and gloves.
----------------------	---	---

6.2. Environmental precautions

Prevent entry to sewers and public waters. Notify authorities if product enters sewers or public waters.

6.3. Methods and material for containment and cleaning up

For containment	:	Impound and recover large spill by mixing it with inert granular solids.
Methods for cleaning up	:	Detergent. Take up liquid spill into absorbent material sand, saw dust, kieselguhr.
Other information	:	Spill area may be slippery. Use suitable disposal containers.

6.4. Reference to other sections

No additional information available

SECTION 7: Handling and storage

7.1 Precautions for safe handling

Precautions for safe handling	:	Avoid all unnecessary exposure. Both local exhaust and general room ventilation are usually required.
Handling temperature	:	< 40 °C
Hygiene measures	:	Wash hands and other exposed areas with mild soap and water before eat, drink or smoke and when leaving work.

7.2. Conditions for safe storage, including any incompatibilities

Storage temperature	:	< 40 °C
Storage area	:	Store in dry, cool, well-ventilated area.

7.3. Specific end use(s)

No additional information available

SECTION 8: Exposure controls/personal

8.1. Control parameters

	: 5 mg/m ³ for oil mists (TWA, 8h-workday) recommended, based upon the ACGIH TLV (Analysis according to US NIOSH Method 5026, NIOSH Manual of Analytical Methods, 3rd Edition).
--	--

8.2. Exposure controls

Personal protective equipment	: Safety glasses. Gloves.
-------------------------------	---------------------------



Hand protection	: Wear suitable gloves resistant to chemical penetration.
Skin and body protection	: No special clothing/skin protection equipment is recommended under normal conditions of use.
Respiratory protection	: No special respiratory protection equipment is recommended under normal conditions of use with adequate ventilation.

SECTION 9: Physical and chemical properties

9.1. Information on basic physical and chemical properties

Physical state	: Liquid
Appearance	: Oily liquid.
Colour	: Blue
Odour	: Characteristic.
Odour threshold	: No data available
pH	: No data available
Relative evaporation rate (butylacetate=1)	: No data available
Melting point	: No data available
Freezing point	: No data available
Boiling point	: No data available
Flash point	: > 180 °C @ ASTM D92
Self ignition temperature	: No data available
Decomposition temperature	: No data available
Flammability (solid, gas)	: No data available
Vapour pressure	: No data available
Relative vapour density at 20 °C	: No data available
Relative density	: No data available
Density	: 872 kg/m ³ @ 15°C
Solubility	: Slightly soluble, the product remains on the water surface.
Log Pow	: No data available
Viscosity, kinematic	: 32 mm ² /s @ 40°C
Viscosity, dynamic	: No data available
Explosive properties	: No data available
Oxidising properties	: No data available
Explosive limits	: No data available

9.2. Other information

No additional information available

SECTION 10: Stability and reactivity

10.1. Reactivity

None under normal conditions.

10.2. Chemical stability

Stable under normal conditions.

K. Kroon Oil Multi purpose grease 3



Page 1/5

Safety data sheet according to 1907/2006/EC, Article 31

Printing date 25.08.2016

Version number 2

Revision: 25.08.2016

SECTION 1: Identification of the substance/mixture and of the company/undertaking

1.1 Product identifier

- Trade name: **Multi Purpose Grease 3**

- Article number: 07.10.02

1.2 Relevant identified uses of the substance or mixture and uses advised against

- Sector of Use
 SU3 Industrial uses: Uses of substances as such or in preparations at industrial sites
 SU21 Consumer uses: Private households / general public / consumers
 SU22 Professional uses: Public domain (administration, education, entertainment, services, craftsmen)

Application of the substance / the mixture

Grease

1.3 Details of the supplier of the safety data sheet

- Manufacturer/Supplier: Kroon Oil BV
 Dollegoorweg 15
 NL-7602 EC ALMELO
 Tel.: +0031-(0)546-818165

Further information obtainable from:

Product safety department - vib@kroon-oil.nl

1.4 Emergency telephone number:

+31 (0)546 818165 (9 AM to 4 PM, Monday to Friday)

NL - National Poison Information Centre (NVIC):
 Tel.nr.: +31 30 - 2748888 - Only for the purpose of informing medical personnel in case of acute intoxications.

SECTION 2: Hazards identification

2.1 Classification of the substance or mixture

- Classification according to Regulation (EC) No 1272/2008 The product is not classified according to the CLP regulation.

2.2 Label elements

- Labelling according to Regulation (EC) No 1272/2008 Void
 - Hazard pictograms Void
 - Signal word Void
 - Hazard statements Void

2.3 Other hazards

Results of PBT and vPvB assessment

- PBT: Not applicable.
 - vPvB: Not applicable.

SECTION 3: Composition/information on ingredients

3.2 Mixtures

- Dangerous components: Void

- Additional information: For the wording of the listed hazard phrases refer to section 16.

SECTION 4: First aid measures

4.1 Description of first aid measures

- General information: No special measures required.
 - After inhalation: Supply fresh air; consult doctor in case of complaints.
 - After skin contact: Generally the product does not irritate the skin.
 - After eye contact: Rinse opened eye for several minutes under running water.
 - After swallowing: Do not induce vomiting; call for medical help immediately.

4.2 Most important symptoms and effects, both acute and delayed

No further relevant information available.

4.3 Indication of any immediate medical attention and special treatment needed

No further relevant information available.

(Contd. on page 2)



Safety data sheet

according to 1907/2006/EC, Article 31

Printing date 25.08.2016

Version number 2

Revision: 25.08.2016

SECTION 1: Identification of the substance/mixture and of the company/undertaking

- 1.1 Product identifier

- Trade name: **Multi Purpose Grease 3**

- Article number: 07.10.02

- 1.2 Relevant identified uses of the substance or mixture and uses advised against

- Sector of Use
 SU3 Industrial uses: Uses of substances as such or in preparations at industrial sites
 SU21 Consumer uses: Private households / general public / consumers
 SU22 Professional uses: Public domain (administration, education, entertainment, services, craftsmen)

- Application of the substance / the mixture
 Grease

- 1.3 Details of the supplier of the safety data sheet

- Manufacturer/Supplier: Kroon Oil BV
 Dollegoorweg 15
 NL-7802 EC ALMELO
 Tel.: +0031-(0)546-818165

- Further information obtainable from: Product safety department - vib@kroon-oil.nl

- 1.4 Emergency telephone number: +31 (0)546 818165 (9 AM to 4 PM, Monday to Friday)

NL - National Poison Information Centre (NVIC):
 Tel.nr.: +31 30 - 2748888 - Only for the purpose of informing medical personnel in case of acute intoxications.

SECTION 2: Hazards identification

- 2.1 Classification of the substance or mixture

- Classification according to Regulation (EC) No 1272/2008 The product is not classified according to the CLP regulation.

- 2.2 Label elements

- Labelling according to Regulation (EC) No 1272/2008 Void
 - Hazard pictograms Void
 - Signal word Void
 - Hazard statements Void

- 2.3 Other hazards

- Results of PBT and vPvB assessment

- PBT: Not applicable.
 - vPvB: Not applicable.

SECTION 3: Composition/information on ingredients

- 3.2 Mixtures

- Dangerous components: Void
 - Additional information: For the wording of the listed hazard phrases refer to section 16.

SECTION 4: First aid measures

- 4.1 Description of first aid measures

- General information: No special measures required.
 - After inhalation: Supply fresh air; consult doctor in case of complaints.
 - After skin contact: Generally the product does not irritate the skin.
 - After eye contact: Rinse opened eye for several minutes under running water.
 - After swallowing: Do not induce vomiting; call for medical help immediately.

- 4.2 Most important symptoms and effects, both acute and delayed

No further relevant information available.

- 4.3 Indication of any immediate medical attention and special treatment needed

No further relevant information available.

(Contd. on page 2)

Safety data sheet

according to 1907/2006/EC, Article 31

Printing date 25.08.2016

Version number 2

Revision: 25.08.2016

Trade name: Multi Purpose Grease 3

(Contd. of page 1)

SECTION 5: Firefighting measures

- 5.1 Extinguishing media
- Suitable extinguishing agents: CO₂, dry chemical, or foam. Water can be used to cool and protect exposed material.
- For safety reasons unsuitable extinguishing agents: Water with full jet
- 5.2 Special hazards arising from the substance or mixture: Formation of toxic gases is possible during heating or in case of fire.
- 5.3 Advice for firefighters
- Protective equipment: Wear self-contained respiratory protective device.
Wear fully protective suit.

SECTION 6: Accidental release measures

- 6.1 Personal precautions, protective equipment and emergency procedures: Wear protective clothing.
- 6.2 Environmental precautions: Do not allow to enter sewers/ surface or ground water.
- 6.3 Methods and material for containment and cleaning up: Absorb with liquid-binding material (sand, diatomite, acid binders, universal binders, sawdust).
Remove from the water surface (e.g. skim or suck off).
- 6.4 Reference to other sections: No dangerous substances are released.
See Section 7 for information on safe handling.
See Section 8 for information on personal protection equipment.
See Section 13 for disposal information.

SECTION 7: Handling and storage

- 7.1 Precautions for safe handling: No special measures required.
Avoid the formation of oil haze.
- Information about fire - and explosion protection: No special measures required.
- 7.2 Conditions for safe storage, including any incompatibilities
- Storage:
 - Requirements to be met by storerooms and receptacles: Store only in the original receptacle.
 - Information about storage in one common storage facility: Not required.
 - Further information about storage conditions: Store in cool, dry conditions in well sealed receptacles.
- 7.3 Specific end use(s): No further relevant information available.

SECTION 8: Exposure controls/personal protection

- Additional information about design of technical facilities: No further data; see item 7.
- 8.1 Control parameters
- Ingredients with limit values that require monitoring at the workplace: Contains mineral oil. Under conditions which may generate mists, observe the OSHA PEL of 5 mg per cubic meter, ACGIH STEL of 10 mg per cubic meter.
The lists valid during the making were used as basis.
- Additional information:
- 8.2 Exposure controls
- Personal protective equipment:
 - General protective and hygienic measures: Wash hands before breaks and at the end of work.
 - Respiratory protection: Not required.
 - Protection of hands:
 -  Wear gloves for the protection against chemicals according to EN 374.
 - Oil resistant gloves
- Material of gloves: Nitrile rubber, NBR
PVC gloves
Neoprene gloves

(Contd. on page 3)

Safety data sheet
according to 1907/2006/EC, Article 31

Printing date 25.08.2016

Version number 2

Revision: 25.08.2016

Trade name: Multi Purpose Grease 3

(Contd. of page 2)

Recommended thickness of the material: ≥ 0.35 mm
The selection of the suitable gloves does not only depend on the material, but also on further marks of quality and varies from manufacturer to manufacturer. As the product is a preparation of several substances, the resistance of the glove material can not be calculated in advance and has therefore to be checked prior to the application.

- Penetration time of glove material

For continuous contact we recommend gloves with breakthrough time of more than 240 minutes with preference for > 480 minutes where suitable gloves can be identified. For short-term/splash protection we recommend the same, but recognise that suitable gloves offering this level of protection may not be available and in this case a lower breakthrough time may be acceptable so long as appropriate maintenance and replacement regimes are followed.
Glove thickness is not a good predictor of glove resistance to a chemical as it is dependent on the exact composition of the glove material.
The exact break trough time has to be found out by the manufacturer of the protective gloves and has to be observed.

- Eye protection:

Goggles recommended during refilling

- Body protection:

Protective work clothing

SECTION 9: Physical and chemical properties

- 9.1 Information on basic physical and chemical properties	
- General Information	
- Appearance:	
Form:	Pasty
Colour:	According to product specification
Odour:	Characteristic
- Change in condition	
Melting point/Melting range:	>190 °C
Boiling point/Boiling range:	>250 °C
Flash point:	>200 °C
Flammability (solid, gaseous):	Not applicable.
Self-igniting:	Product is not selfigniting.
Danger of explosion:	Product does not present an explosion hazard.
- Explosion limits:	
Lower:	Not determined.
Upper:	Not determined.
Density at 20 °C:	0.94 g/cm ³
- Solubility in / Miscibility with water:	
Not miscible or difficult to mix.	
- Partition coefficient (n-octanol/water): Not determined.	
- Solvent content:	
Organic solvents:	0.0 %
9.2 Other information	No further relevant information available.

SECTION 10: Stability and reactivity

- 10.1 Reactivity No further relevant information available.
- 10.2 Chemical stability
- Thermal decomposition / conditions to be avoided: To avoid thermal decomposition do not overheat.
- 10.3 Possibility of hazardous reactions Reacts with strong oxidising agents.
- 10.4 Conditions to avoid No further relevant information available.
- 10.5 Incompatible materials: No further relevant information available.
- 10.6 Hazardous decomposition products: No dangerous decomposition products known.

SECTION 11: Toxicological information

- 11.1 Information on toxicological effects
- Acute toxicity Based on available data, the classification criteria are not met.
- Primary irritant effect:
- Skin corrosion/irritation Based on available data, the classification criteria are not met.
- Serious eye damage/irritation Based on available data, the classification criteria are not met.

(Contd. on page 4)

Safety data sheet

according to 1907/2006/EC, Article 31

Printing date 25.08.2018

Version number 2

Revision: 25.08.2018

Trade name: Multi Purpose Grease 3

(Contd. of page 3)

- Respiratory or skin sensitisation Based on available data, the classification criteria are not met.
- CMR effects (carcinogenity, mutagenicity and toxicity for reproduction) This product contains mineral oils which are considered to be severely refined and not considered to be carcinogenic under IARC. All of the oils in this product have been demonstrated to contain less than 3% extractables by the IP 348 test.
- Germ cell mutagenicity Based on available data, the classification criteria are not met.
- Carcinogenicity Based on available data, the classification criteria are not met.
- Reproductive toxicity Based on available data, the classification criteria are not met.
- STOT-single exposure Based on available data, the classification criteria are not met.
- STOT-repeated exposure Based on available data, the classification criteria are not met.
- Aspiration hazard Based on available data, the classification criteria are not met.

SECTION 12: Ecological information

- 12.1 Toxicity
- Aquatic toxicity: No further relevant information available.
- 12.2 Persistence and degradability
- Other information: No further relevant information available.
- 12.3 Bioaccumulative potential The product is not easily biodegradable.
- 12.4 Mobility in soil No further relevant information available.
- Ecotoxicological effects:
- Remark: This material is not expected to be harmful to aquatic organisms. The product has not been tested. The statement has been derived from the properties of the individual components.
- Additional ecological information:
- General notes: Water hazard class 1 (German Regulation) (Self-assessment): slightly hazardous for water
Do not allow undiluted product or large quantities of it to reach ground water, water course or sewage system.
- 12.5 Results of PBT and vPvB assessment
- PBT: Not applicable.
- vPvB: Not applicable.
- 12.6 Other adverse effects No further relevant information available.

SECTION 13: Disposal considerations

- 13.1 Waste treatment methods
- Recommendation: Must not be disposed together with household garbage. Do not allow product to reach sewage system.

- European waste catalogue	
12 01 12*	spent waxes and fats

- Uncleaned packaging:
- Recommendation: Disposal must be made according to official regulations.

SECTION 14: Transport information

- 14.1 UN-Number	
- ADR,ADN, ADN, IMDG, IATA	Void
- 14.2 UN proper shipping name	
- ADR,ADN, ADN, IMDG, IATA	Void
- 14.3 Transport hazard class(es)	
- ADR,ADN, ADN, IMDG, IATA	
- Class	Void
- 14.4 Packing group	
- ADR,ADN, IMDG, IATA	Void
- 14.5 Environmental hazards:	
- Marine pollutant:	No
- 14.6 Special precautions for user	Not applicable.
- 14.7 Transport in bulk according to Annex II of Marpol and the IBC Code	Not applicable.

(Contd. on page 5)

Safety data sheet
according to 1907/2006/EC, Article 31

Printing date 25.08.2016

Version number 2

Revision: 25.08.2016

Trade name: Multi Purpose Grease 3

(Contd. of page 4)

- UN "Model Regulation":	Void
--------------------------	------

SECTION 15: Regulatory information

- 15.1 Safety, health and environmental regulations/legislation specific for the substance or mixture
- Directive 2012/18/EU
- Named dangerous substances
 - ANNEX I None of the ingredients is listed.
- National regulations:
- Waterhazard class: Water hazard class 1 (Self-assessment): slightly hazardous for water.
- 15.2 Chemical safety assessment: A Chemical Safety Assessment has not been carried out.

SECTION 16: Other information

This information is based on our present knowledge. However, this shall not constitute a guarantee for any specific product features and shall not establish a legally valid contractual relationship.

- Department issuing SDS: Product safety department.
- Contact: Product safety department
- Abbreviations and acronyms:
 - RID: Règlement International concernant le transport des marchandises dangereuses par chemin de fer (Regulations Concerning the International Transport of Dangerous Goods by Rail)
 - ICAO: International Civil Aviation Organisation
 - ADR: Accord européen sur le transport des marchandises dangereuses par Route (European Agreement concerning the International Carriage of Dangerous Goods by Road)
 - IMDG: International Maritime Code for Dangerous Goods
 - IATA: International Air Transport Association
 - GHS: Globally Harmonised System of Classification and Labelling of Chemicals
 - EINECS: European Inventory of Existing Commercial Chemical Substances
 - ELINCS: European List of Notified Chemical Substances
 - CAS: Chemical Abstracts Service (division of the American Chemical Society)
 - PBT: Persistent, Bioaccumulative and Toxic
 - vPvB: very Persistent and very Bioaccumulative
- Sources: EC/453-2010

L. Torque settings

Inspect all bolt joints which may pose a hazard to people and machines at fixed intervals and check their torque. Apply the torque values unless indicated otherwise on the drawing.

Nominal size	Strength class	Course pitch [Nm]	Fine pitch [Nm]
		(Copper-grease) 0.08	(Copper-grease) 0.08
M4	8.8	2.2	
	10.9	3.2	
	12.9	3.8	
M5	8.8	4.3	
	10.9	6.3	
	12.9	7.4	
M6	8.8	7.4	
	10.9	10.9	
	12.9	12.5	
M7	8.8	12.0	
	10.9	17.5	
	12.9	20.5	
M8	8.8	18	19
	10.9	26	28
	12.9	31	32
M10	8.8	36	37
	10.9	52	55
	12.9	61	64
M12	8.8	61	63
	10.9	90	93
	12.9	105	109
M14	8.8	97	103
	10.9	145	150
	12.9	165	175
M16	8.8	145	155
	10.9	215	225
	12.9	250	270
M18	8.8	210	230
	10.9	300	330
	12.9	350	380
M20	8.8	300	320
	10.9	420	460
	12.9	500	530
M22	8.8	400	430

Nominal size	Strength class	Course pitch [Nm]	Fine pitch [Nm]
		(Copper-grease)	(Copper-grease)
		0.08	0.08
	10.9	570	610
	12.9	670	710
M24	8.8	510	640
	10.9	730	900
	12.9	850	1060
M27	8.8	750	920
	10.9	1070	1310
	12.9	1250	1530
M30	8.8	1000	1280
	10.9	1450	1820
	12.9	1700	2130
M33	8.8	1400	1700
	10.9	1950	2430
	12.9	2300	2840
M36	8.8	1750	2230
	10.9	2500	3170
	12.9	3000	3710
M39	8.8	2300	2850
	10.9	3300	4050
	12.9	3800	4740