

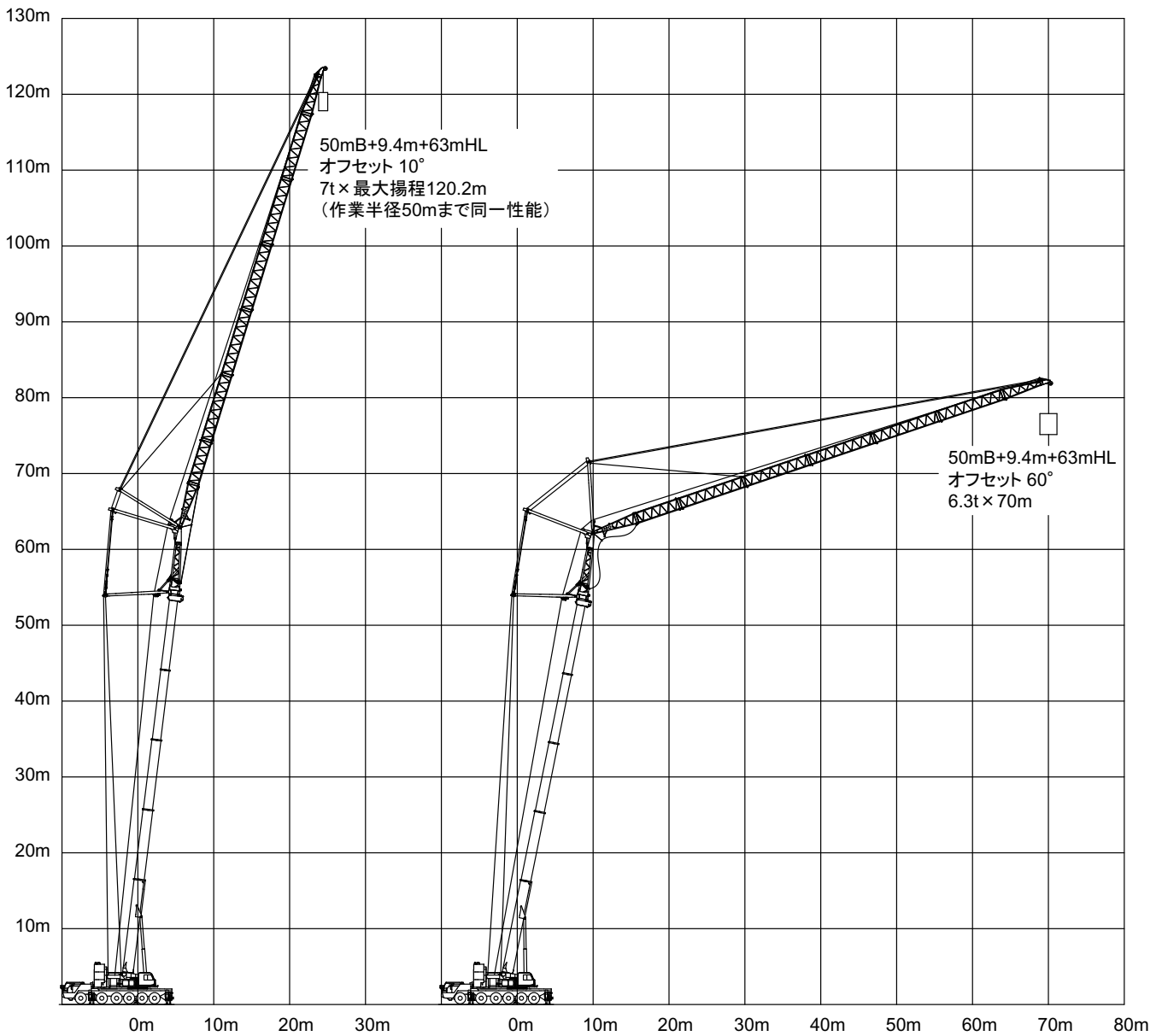

ヘビーリフトジブ作業概念図

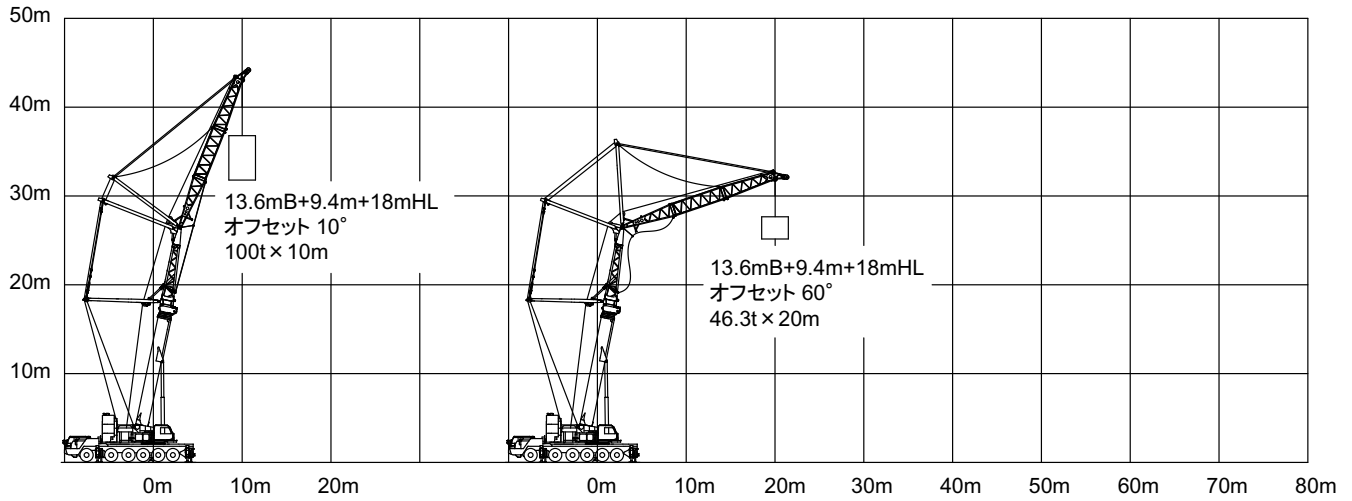



ヘビーリフトジブ作業概念図

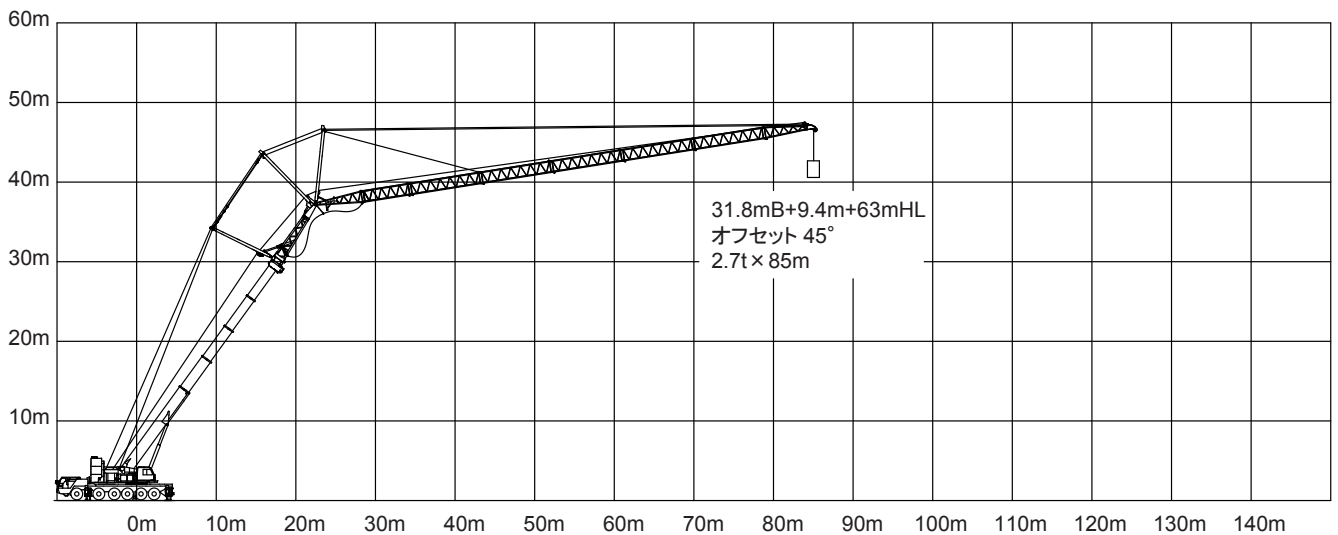
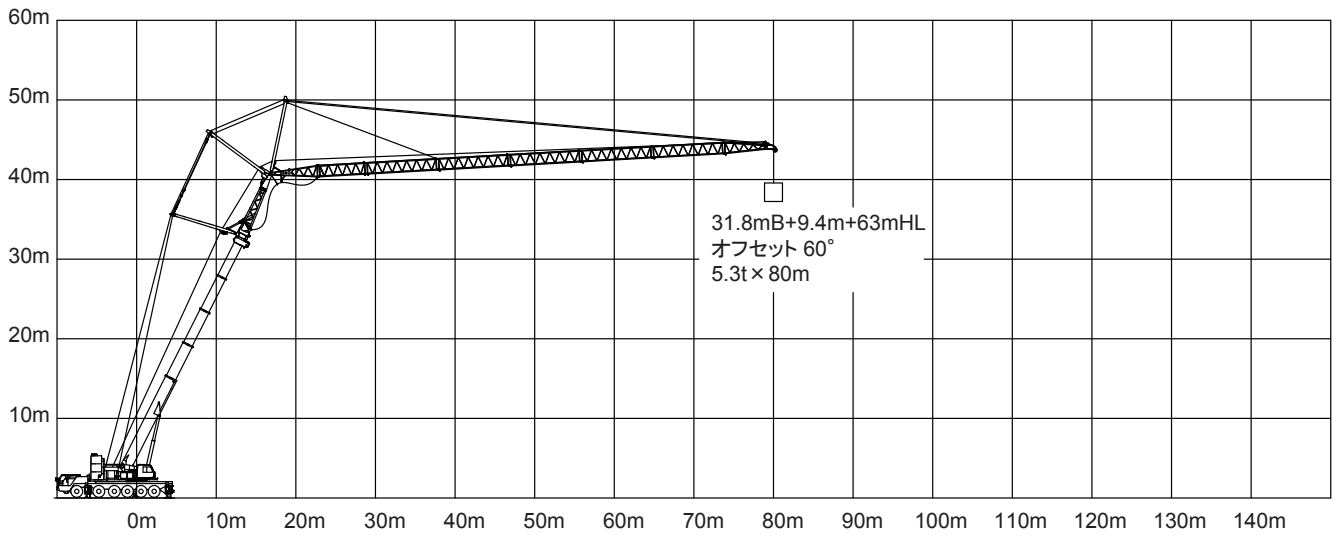
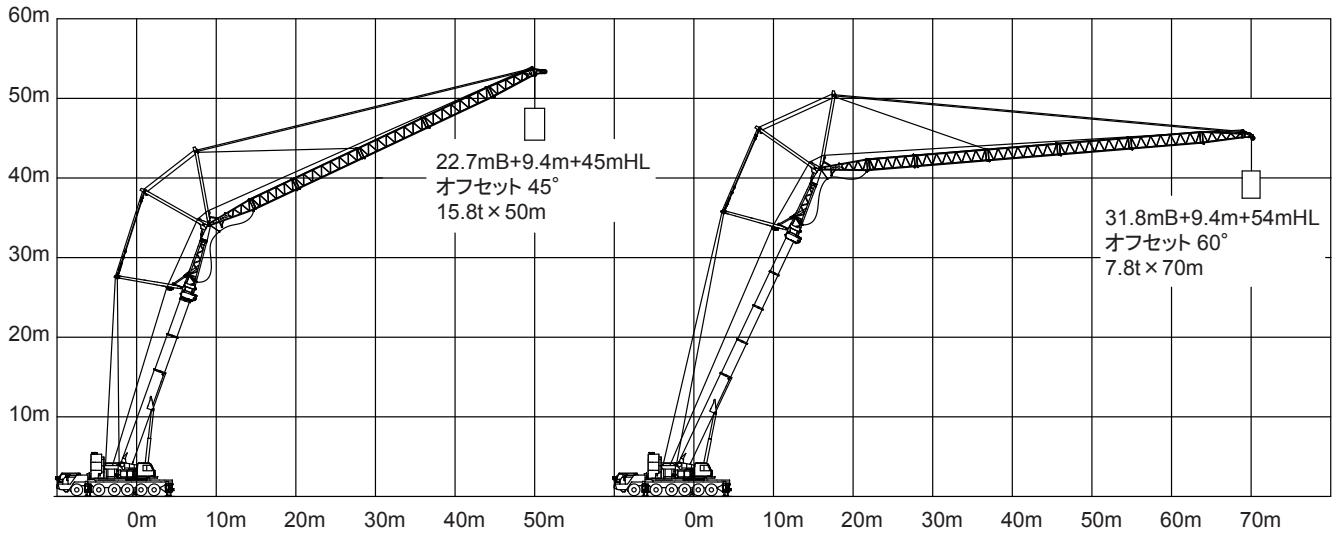



ヘビーリフトジブ作業範囲図

- | | |
|--|--|
| Ⓐ 13.6mブーム+9.4m+18mヘビーリフトジブ (オフセット10°) | Ⓔ 50.0mブーム+9.4m+63mヘビーリフトジブ (オフセット10°) |
| Ⓑ 13.6mブーム+9.4m+18mヘビーリフトジブ (オフセット60°) | ⓐ 50.0mブーム+9.4m+36mヘビーリフトジブ (オフセット60°) |
| Ⓒ 50.0mブーム+9.4m+36mヘビーリフトジブ (オフセット10°) | ⓑ 50.0mブーム+9.4m+45mヘビーリフトジブ (オフセット60°) |
| Ⓓ 50.0mブーム+9.4m+45mヘビーリフトジブ (オフセット10°) | ⓓ 50.0mブーム+9.4m+54mヘビーリフトジブ (オフセット60°) |
| Ⓔ 50.0mブーム+9.4m+54mヘビーリフトジブ (オフセット10°) | ⓔ 50.0mブーム+9.4m+63mヘビーリフトジブ (オフセット60°) |

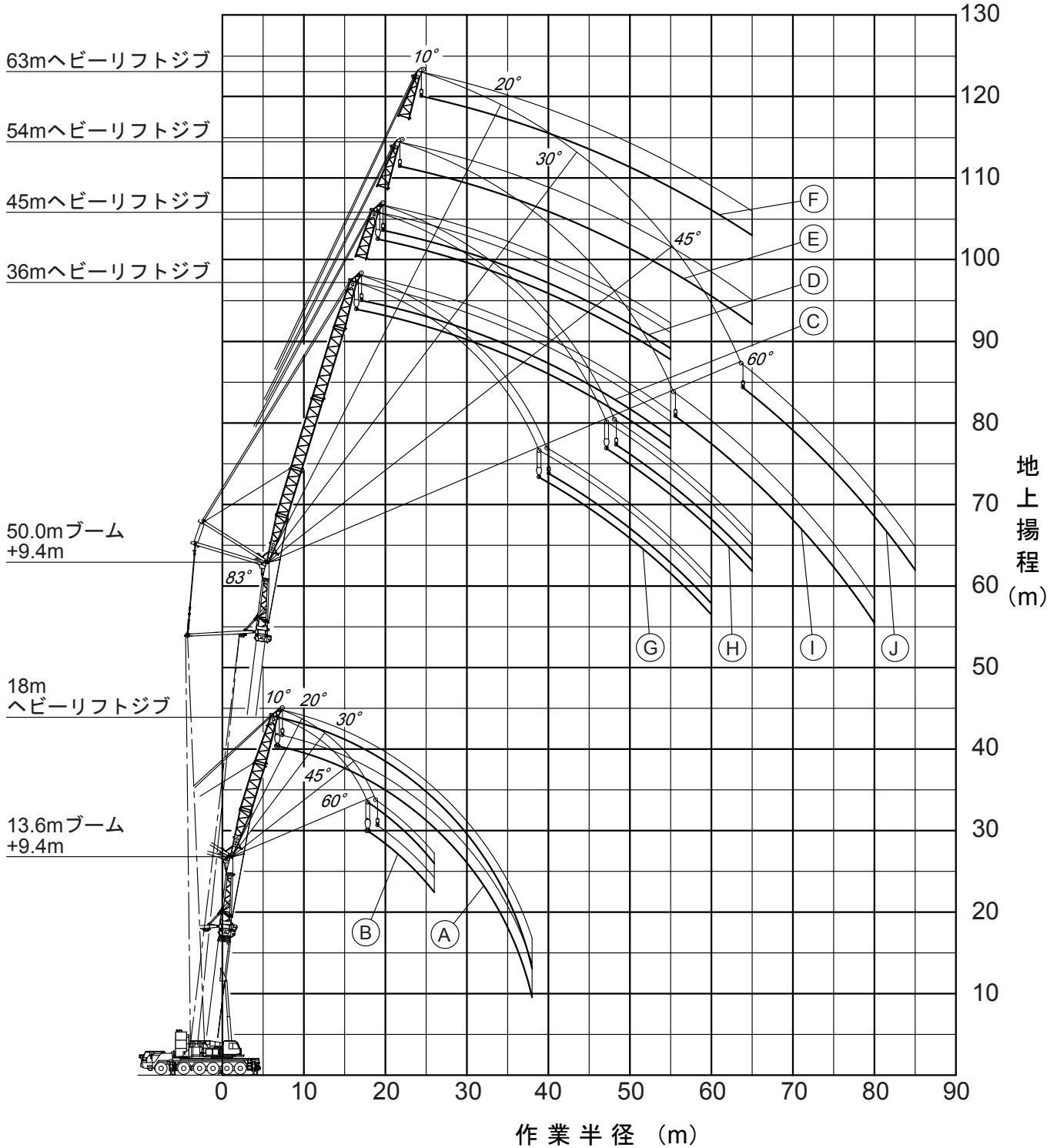

- 注) 1. 本図はブームおよびヘビーリフトジブのたわみを含んでいません。
 2. HSおよびHA性能時のものを示しています。

HB性能 13.6mブーム+9.4m+18mヘビーリフトジブ

オフセット	10°	20°	30°	45°	60°
作業半径 (m)	荷重 (ton)	荷重 (ton)	荷重 (ton)	荷重 (ton)	荷重 (ton)
7.0	100.0				
8.0	100.0				
9.0	100.0				
10.0	91.6				
11.0	83.0	86.1			
12.0	75.7	78.5			
14.0	63.8	66.2	67.7		
16.0	54.3	56.6	58.6		
18.0	46.3	48.3	50.1	51.8	
20.0	39.8	41.5	42.8	44.6	46.0
22.0	34.2	35.4	36.6	38.0	39.1
24.0	29.6	30.6	31.5	32.7	33.5
26.0	25.8	26.6	27.4	28.4	28.9
28.0	22.6	23.3	24.0	24.7	
30.0	19.9	20.5	21.1	21.6	
32.0	17.6	18.1	18.5	18.8	
34.0	15.6	16.0	16.3		
36.0	13.9	14.1	14.2		
38.0	12.3				
危険角度 (°)	10	20	30	45	60
フック種類	200t	200t	200t	200t	200t
フック質量 (t)	2.60	2.60	2.60	2.60	2.60
掛数	10	10	10	10	10

HC性能 13.6mブーム+9.4m+18mヘビーリフトジブ

オフセット	10°	20°	30°	45°	60°
作業半径 (m)	荷重 (ton)	荷重 (ton)	荷重 (ton)	荷重 (ton)	荷重 (ton)
7.0	100.0				
8.0	98.2				
9.0	87.4				
10.0	78.4				
11.0	70.8	73.9			
12.0	64.4	67.2			
14.0	53.3	56.0	58.6		
16.0	44.4	46.7	48.9		
18.0	37.5	39.4	41.3	43.4	
20.0	31.9	33.3	34.6	36.4	37.7
22.0	27.1	28.3	29.4	30.8	31.9
24.0	23.3	24.2	25.2	26.3	27.1
26.0	20.1	20.9	21.7	22.6	23.1
28.0	17.4	18.1	18.8	19.5	
30.0	15.1	15.8	16.3	16.8	
32.0	13.1	13.6	14.0	14.3	
34.0	11.3	11.8	12.1		
36.0	9.6	10.0	10.1		
38.0	8.1				
危険角度 (°)	10	20	30	45	60
フック種類	200t	200t	200t	200t	200t
フック質量 (t)	2.60	2.60	2.60	2.60	2.60
掛数	10	10	10	10	10

HB性能 22.7mブーム+9.4m+18mヘビーリフトジブ

オフセット	10°	20°	30°	45°	60°
作業半径 (m)	荷重 (ton)	荷重 (ton)	荷重 (ton)	荷重 (ton)	荷重 (ton)
10.0	75.0				
11.0	75.0				
12.0	73.0				
14.0	60.9	64.1			
16.0	51.1	54.2	56.9		
18.0	43.0	45.6	48.1		
20.0	36.5	38.8	41.0	43.4	
22.0	31.2	33.2	34.7	36.7	38.2
24.0	26.7	28.3	29.7	31.4	32.6
26.0	23.0	24.4	25.5	26.9	27.9
28.0	19.8	21.0	22.0	23.2	23.9
30.0	17.0	18.2	19.1	20.1	20.6
32.0	14.5	15.6	16.5	17.4	17.7
34.0	12.4	13.4	14.2	15.0	
36.0	10.4	11.3	12.0	12.6	
38.0	8.7	9.5	10.0	10.4	
40.0	7.2	7.8	8.2		
42.0	5.8	6.3	6.5		
危険角度 (°)	31	33	34	45	60
フック種類	200t	200t	200t	200t	200t
フック質量 (t)	2.60	2.60	2.60	2.60	2.60
掛数	8	8	8	8	8

HC性能 22.7mブーム+9.4m+18mヘビーリフトジブ

オフセット	10°	20°	30°	45°	60°
作業半径 (m)	荷重 (ton)	荷重 (ton)	荷重 (ton)	荷重 (ton)	荷重 (ton)
10.0	75.0				
11.0	68.2				
12.0	61.7				
14.0	50.2	53.8			
16.0	41.2	44.2	47.1		
18.0	34.2	36.8	39.3		
20.0	28.5	30.9	32.9	35.2	
22.0	23.9	26.0	27.6	29.6	31.0
24.0	20.1	21.9	23.3	25.0	26.2
26.0	16.9	18.5	19.8	21.2	22.1
28.0	14.1	15.5	16.8	18.0	18.7
30.0	11.7	12.9	14.1	15.3	15.8
32.0	9.5	10.7	11.6	12.7	13.1
34.0	7.7	8.7	9.5	10.4	
36.0	6.0	6.9	7.6	8.2	
38.0			5.8	6.3	
危険角度 (°)	44	46	46	46	60
フック種類	200t	200t	200t	200t	200t
フック質量 (t)	2.60	2.60	2.60	2.60	2.60
掛数	8	8	8	8	8

HB性能 31.8mブーム+9.4m+18mヘビーリフトジブ

オフセット	10°	20°	30°	45°	60°
作業半径 (m)	荷重 (ton)	荷重 (ton)	荷重 (ton)	荷重 (ton)	荷重 (ton)
12.0	60.0				
14.0	60.0				
16.0	50.5	53.8			
18.0	42.4	45.2	47.9		
20.0	35.9	38.4	40.7	43.4	
22.0	30.5	32.8	34.6	36.7	
24.0	26.1	28.0	29.5	31.4	32.7
26.0	22.3	24.0	25.3	26.9	28.0
28.0	19.1	20.7	21.8	23.2	24.1
30.0	16.3	17.7	18.9	20.1	20.8
32.0	13.8	15.1	16.3	17.4	17.9
34.0	11.6	12.9	13.9	15.0	15.4
36.0	9.7	10.8	11.7	12.7	13.0
38.0	8.0	9.0	9.8	10.6	
40.0	6.4	7.3	8.0	8.7	
42.0	5.0	5.8	6.4	6.9	
44.0		4.4	4.9	5.3	
危険角度 (°)	45	45	45	45	60
フック種類	83t	83t	83t	83t	83t
フック質量 (t)	1.35	1.35	1.35	1.35	1.35
掛数	6	6	6	6	6

HC性能 31.8mブーム+9.4m+18mヘビーリフトジブ

オフセット	10°	20°	30°	45°	60°
作業半径 (m)	荷重 (ton)	荷重 (ton)	荷重 (ton)	荷重 (ton)	荷重 (ton)
12.0	60.0				
14.0	49.7				
16.0	40.6	43.9			
18.0	33.6	36.4	39.1		
20.0	27.9	30.4	32.8	35.2	
22.0	23.3	25.5	27.4	29.6	
24.0	19.4	21.5	23.1	25.0	26.3
26.0	16.2	18.0	19.6	21.2	22.3
28.0	13.4	15.0	16.5	18.0	18.9
30.0	11.0	12.4	13.7	15.3	16.0
32.0	8.8	10.2	11.3	12.7	13.4
34.0	7.0	8.2	9.2	10.4	10.9
36.0	5.3	6.4	7.3	8.3	8.6
38.0		4.8	5.6	6.4	
40.0			4.0	4.7	
危険角度 (°)	53	53	53	53	60
フック種類	83t	83t	83t	83t	83t
フック質量 (t)	1.35	1.35	1.35	1.35	1.35
掛数	6	6	6	6	6

HD性能 13.6mブーム+9.4m+18mヘビーリフトジブ

オフセット	10°	20°	30°	45°	60°
作業半径 (m)	荷重 (ton)	荷重 (ton)	荷重 (ton)	荷重 (ton)	荷重 (ton)
7.0	100.0				
8.0	93.4				
9.0	83.1				
10.0	74.5				
11.0	66.3	69.8			
12.0	59.2	62.5			
14.0	46.7	49.1	51.4		
16.0	37.1	39.1	41.0		
18.0	30.2	31.9	33.4	35.5	
20.0	25.0	26.4	27.7	29.5	30.8
22.0	21.0	22.2	23.3	24.7	25.7
24.0	17.7	18.7	19.6	20.8	21.6
26.0	15.0	15.9	16.7	17.6	18.1
28.0	12.8	13.5	14.2	14.9	
30.0	10.9	11.5	12.0	12.5	
32.0	9.3	9.8	10.1	10.4	
34.0	7.9	8.2	8.5		
36.0	6.6	6.8	6.9		
危険角度 (°)	20	20	30	45	60
フック種類	200t	200t	200t	200t	200t
フック質量 (t)	2.60	2.60	2.60	2.60	2.60
掛数	10	10	10	10	10

HD性能 22.7mブーム+9.4m+18mヘビーリフトジブ

オフセット	10°	20°	30°	45°	60°
作業半径 (m)	荷重 (ton)	荷重 (ton)	荷重 (ton)	荷重 (ton)	荷重 (ton)
10.0	71.9				
11.0	63.4				
12.0	56.3				
14.0	44.0	47.2			
16.0	34.5	37.1	39.5		
18.0	27.6	29.8	31.9		
20.0	22.4	24.3	26.0	28.3	
22.0	18.3	20.0	21.5	23.4	24.9
24.0	15.1	16.5	17.8	19.5	20.6
26.0	12.4	13.6	14.8	16.2	17.1
28.0	10.2	11.2	12.2	13.4	14.1
30.0	8.3	9.2	10.1	11.1	11.5
32.0	6.3	7.5	8.2	9.0	9.3
34.0			6.4	7.2	
危険角度 (°)	50	53	53	54	60
フック種類	200t	200t	200t	200t	200t
フック質量 (t)	2.60	2.60	2.60	2.60	2.60
掛数	8	8	8	8	8

HD性能 31.8mブーム+9.4m+18mヘビーリフトジブ

オフセット	10°	20°	30°	45°	60°
作業半径 (m)	荷重 (ton)	荷重 (ton)	荷重 (ton)	荷重 (ton)	荷重 (ton)
12.0	55.8				
14.0	43.6				
16.0	34.1	36.8			
18.0	27.2	29.5	31.7		
20.0	22.0	24.0	25.9	28.3	
22.0	17.9	19.7	21.3	23.4	
24.0	14.6	16.2	17.6	19.4	20.8
26.0	11.9	13.3	14.6	16.2	17.2
28.0	9.7	10.9	12.0	13.4	14.3
30.0	7.8	8.9	9.9	11.0	11.8
32.0	5.6	7.0	8.0	9.0	9.6
34.0		5.0	6.1	7.2	7.9
36.0			4.2	5.3	5.7
危険角度 (°)	58	58	58	60	60
フック種類	83t	83t	83t	83t	83t
フック質量 (t)	1.35	1.35	1.35	1.35	1.35
掛数	6	6	6	6	6

HS性能 22.7mブーム+9.4m+27mヘビーリフトジブ

オフセット	10°	20°	30°	45°	60°
作業半径 (m)	荷重 (ton)	荷重 (ton)	荷重 (ton)	荷重 (ton)	荷重 (ton)
14.0	60.0				
16.0	60.0				
18.0	59.1	52.6			
20.0	52.6	51.0			
22.0	45.9	48.8	45.2		
24.0	40.4	43.0	43.2		
26.0	35.7	38.1	40.3	35.7	
28.0	31.7	33.8	35.9	34.6	
30.0	28.2	30.2	32.0	33.6	30.7
32.0	25.2	26.9	28.6	30.8	30.1
34.0	22.5	24.1	25.6	27.6	28.9
36.0	20.1	21.6	22.9	24.6	25.8
38.0	17.9	19.3	20.5	22.0	22.9
40.0	16.0	17.2	18.3	19.6	20.2
42.0	14.3	15.3	16.3	17.4	
44.0	12.7	13.6	14.5	15.3	
46.0	11.2	12.1	12.8	13.4	
48.0	9.9	10.6	11.2		
50.0	8.6	9.2	9.7		
55.0	5.2	5.8			
危険角度 (°)	10	20	30	45	60
フック種類	83t	83t	83t	83t	83t
フック質量 (t)	1.35	1.35	1.35	1.35	1.35
掛数	6	6	6	6	6

HA性能 22.7mブーム+9.4m+27mヘビーリフトジブ

オフセット	10°	20°	30°	45°	60°
作業半径 (m)	荷重 (ton)	荷重 (ton)	荷重 (ton)	荷重 (ton)	荷重 (ton)
14.0	60.0				
16.0	60.0				
18.0	57.8	52.6			
20.0	50.6	51.0			
22.0	44.6	47.3	45.2		
24.0	39.6	42.0	43.2		
26.0	35.2	37.5	39.6	35.7	
28.0	31.5	33.5	35.4	34.6	
30.0	28.2	30.1	31.8	33.6	30.7
32.0	25.2	26.9	28.6	30.7	30.1
34.0	22.5	24.1	25.6	27.6	28.9
36.0	20.1	21.6	22.9	24.6	25.8
38.0	17.9	19.3	20.5	22.0	22.9
40.0	16.0	17.2	18.3	19.6	20.2
42.0	14.3	15.3	16.3	17.4	
44.0	12.7	13.6	14.5	15.3	
46.0	11.2	12.1	12.8	13.4	
48.0	9.9	10.6	11.2		
50.0	8.6	9.2	9.7		
55.0	5.2	5.8			
危険角度 (°)	10	20	30	45	60
フック種類	83t	83t	83t	83t	83t
フック質量 (t)	1.35	1.35	1.35	1.35	1.35
掛数	6	6	6	6	6

HA性能 31.8mブーム+9.4m+27mヘビーリフトジブ

オフセット	10°	20°	30°	45°	60°
作業半径 (m)	荷重 (ton)	荷重 (ton)	荷重 (ton)	荷重 (ton)	荷重 (ton)
16.0	45.0				
18.0	45.0				
20.0	45.0	45.0			
22.0	43.5	45.0			
24.0	38.5	41.2	43.5		
26.0	34.1	36.6	38.9		
28.0	30.3	32.6	34.7	35.7	
30.0	27.0	29.1	31.1	33.7	
32.0	24.0	26.0	27.9	30.2	31.1
34.0	21.3	23.1	24.8	27.1	28.7
36.0	18.9	20.6	22.1	24.2	25.6
38.0	16.7	18.3	19.7	21.5	22.7
40.0	14.8	16.2	17.5	19.2	20.1
42.0	13.0	14.4	15.6	17.0	17.8
44.0	11.5	12.7	13.7	15.0	15.6
46.0	10.0	11.1	12.1	13.2	
48.0	8.7	9.7	10.6	11.5	
50.0	7.4	8.4	9.1	9.9	
55.0	4.8	5.5	6.0		
危険角度 (°)	35	35	35	45	60
フック種類	83t	83t	83t	83t	83t
フック質量 (t)	1.35	1.35	1.35	1.35	1.35
掛数	4	4	4	4	4

HA性能 40.9mブーム+9.4m+27mヘビーリフトジブ

オフセット	10°	20°	30°	45°	60°
作業半径 (m)	荷重 (ton)	荷重 (ton)	荷重 (ton)	荷重 (ton)	荷重 (ton)
16.0	30.0				
18.0	30.0				
20.0	30.0	30.0			
22.0	30.0	30.0			
24.0	30.0	30.0	30.0		
26.0	30.0	30.0	30.0		
28.0	27.4	29.6	30.0		
30.0	24.8	26.7	28.6	30.0	
32.0	22.2	24.2	25.8	27.6	28.7
34.0	19.5	21.7	23.3	24.8	25.7
36.0	17.1	19.1	21.0	22.3	23.0
38.0	14.9	16.8	18.5	20.0	20.6
40.0	13.0	14.7	16.3	18.0	18.4
42.0	11.2	12.8	14.3	16.1	16.4
44.0	9.6	11.1	12.4	14.0	14.7
46.0	8.1	9.5	10.7	12.2	12.9
48.0	6.8	8.1	9.2	10.5	11.0
50.0	5.5	6.7	7.8	8.9	9.3
55.0		3.8	4.6	5.4	
危険角度 (°)	48	48	48	50	60
フック種類	83t	83t	83t	83t	83t
フック質量 (t)	1.35	1.35	1.35	1.35	1.35
掛数	4	4	4	4	4

HB性能 22.7mブーム+9.4m+27mヘビーリフトジブ

オフセット	10°	20°	30°	45°	60°
作業半径 (m)	荷重 (ton)	荷重 (ton)	荷重 (ton)	荷重 (ton)	荷重 (ton)
14.0	60.0				
16.0	54.2				
18.0	45.9	49.6			
20.0	39.3	42.6			
22.0	33.9	36.4	38.6		
24.0	29.2	31.3	33.3		
26.0	25.3	27.2	29.0	31.4	
28.0	22.1	23.7	25.3	27.5	
30.0	19.3	20.8	22.2	24.1	25.6
32.0	16.9	18.3	19.5	21.2	22.5
34.0	14.7	16.1	17.2	18.7	19.8
36.0	12.7	14.2	15.2	16.5	17.4
38.0	11.0	12.3	13.4	14.5	15.2
40.0	9.4	10.6	11.7	12.7	13.2
42.0	7.9	9.0	10.0	11.1	
44.0	6.6	7.6	8.4	9.3	
46.0	5.4	6.3	7.0	7.6	
48.0	4.4	5.1	5.7		
50.0			4.4		
危険角度 (°)	36	39	39	45	60
フック種類	83t	83t	83t	83t	83t
フック質量 (t)	1.35	1.35	1.35	1.35	1.35
掛数	6	6	6	6	6

HC性能 22.7mブーム+9.4m+27mヘビーリフトジブ

オフセット	10°	20°	30°	45°	60°
作業半径 (m)	荷重 (ton)	荷重 (ton)	荷重 (ton)	荷重 (ton)	荷重 (ton)
14.0	53.5				
16.0	44.3				
18.0	37.1	40.8			
20.0	31.4	34.5			
22.0	26.7	29.2	31.4		
24.0	22.7	24.9	26.9		
26.0	19.4	21.4	23.2	25.6	
28.0	16.6	18.5	20.0	22.2	
30.0	14.1	16.0	17.4	19.3	20.8
32.0	11.9	13.7	15.1	16.8	18.0
34.0	10.0	11.6	13.1	14.6	15.6
36.0	8.3	9.8	11.1	12.6	13.5
38.0	6.8	8.1	9.3	10.8	11.5
40.0	5.4	6.6	7.7	9.0	9.6
42.0	4.2	5.3	6.2	7.3	
44.0		4.0	4.8	5.7	
46.0				4.2	
危険角度 (°)	46	46	49	49	60
フック種類	83t	83t	83t	83t	83t
フック質量 (t)	1.35	1.35	1.35	1.35	1.35
掛数	6	6	6	6	6

HB性能 31.8mブーム+9.4m+27mヘビーリフトジブ

オフセット	10°	20°	30°	45°	60°
作業半径 (m)	荷重 (ton)	荷重 (ton)	荷重 (ton)	荷重 (ton)	荷重 (ton)
16.0	45.0				
18.0	44.9				
20.0	38.2	41.8			
22.0	32.7	35.8			
24.0	28.2	30.7	32.9		
26.0	24.3	26.5	28.5		
28.0	21.0	23.0	24.8	27.2	
30.0	18.2	20.1	21.7	23.8	
32.0	15.7	17.6	19.0	20.9	22.4
34.0	13.5	15.3	16.7	18.4	19.7
36.0	11.5	13.2	14.7	16.2	17.3
38.0	9.8	11.3	12.8	14.2	15.1
40.0	8.2	9.6	10.9	12.4	13.2
42.0	6.7	8.1	9.3	10.7	11.4
44.0	5.4	6.7	7.7	9.0	9.6
46.0	4.2	5.4	6.3	7.4	
48.0		4.2	5.0	6.0	
50.0				4.6	
危険角度 (°)	49	50	52	52	60
フック種類	83t	83t	83t	83t	83t
フック質量 (t)	1.35	1.35	1.35	1.35	1.35
掛数	4	4	4	4	4

HC性能 31.8mブーム+9.4m+27mヘビーリフトジブ

オフセット	10°	20°	30°	45°	60°
作業半径 (m)	荷重 (ton)	荷重 (ton)	荷重 (ton)	荷重 (ton)	荷重 (ton)
16.0	43.3				
18.0	36.0				
20.0	30.3	33.8			
22.0	25.5	28.6			
24.0	21.6	24.3	26.4		
26.0	18.2	20.8	22.7		
28.0	15.4	17.8	19.5	21.9	
30.0	12.9	15.1	16.9	19.0	
32.0	10.7	12.7	14.6	16.5	17.9
34.0	8.8	10.7	12.4	14.3	15.5
36.0	7.1	8.8	10.4	12.3	13.4
38.0	5.6	7.2	8.6	10.4	11.4
40.0	4.2	5.7	6.9	8.6	9.5
42.0		4.3	5.5	6.9	7.7
44.0			4.1	5.4	5.9
46.0				4.0	
危険角度 (°)	54	57	57	58	60
フック種類	83t	83t	83t	83t	83t
フック質量 (t)	1.35	1.35	1.35	1.35	1.35
掛数	4	4	4	4	4

HB性能 40.9mブーム+9.4m+27mヘビーリフトジブ

オフセット	10°	20°	30°	45°	60°
作業半径 (m)	荷重 (ton)	荷重 (ton)	荷重 (ton)	荷重 (ton)	荷重 (ton)
16.0	30.0				
18.0	30.0				
20.0	30.0	30.0			
22.0	30.0	30.0			
24.0	26.6	29.8	30.0		
26.0	22.7	25.6	27.8		
28.0	19.4	22.1	24.1		
30.0	16.5	19.1	21.0	23.4	
32.0	13.9	16.3	18.2	20.4	22.1
34.0	11.7	13.9	15.9	17.9	19.3
36.0	9.7	11.8	13.6	15.6	16.9
38.0	7.9	9.8	11.5	13.6	14.7
40.0	6.3	8.1	9.7	11.6	12.8
42.0	4.9	6.5	8.0	9.7	10.8
44.0		5.1	6.4	8.0	8.9
46.0			5.0	6.4	7.1
48.0				5.0	5.5
50.0					4.0
危険角度 (°)	59	60	61	61	61
フック種類	83t	83t	83t	83t	83t
フック質量 (t)	1.35	1.35	1.35	1.35	1.35
掛数	4	4	4	4	4

HC性能 40.9mブーム+9.4m+27mヘビーリフトジブ

オフセット	10°	20°	30°	45°	60°
作業半径 (m)	荷重 (ton)	荷重 (ton)	荷重 (ton)	荷重 (ton)	荷重 (ton)
16.0	30.0				
18.0	30.0				
20.0	28.7	30.0			
22.0	24.0	27.7			
24.0	20.0	23.3	25.9		
26.0	16.6	19.7	22.1		
28.0	13.7	16.5	18.9		
30.0	11.2	13.8	16.1	18.5	
32.0	9.0	11.4	13.5	16.0	17.6
34.0	7.0	9.2	11.2	13.7	15.2
36.0	5.3	7.4	9.2	11.6	13.0
38.0		5.7	7.4	9.5	11.0
40.0			5.7	7.7	8.9
42.0				6.0	7.0
44.0				4.4	5.3
危険角度 (°)	65	65	66	66	68
フック種類	83t	83t	83t	83t	83t
フック質量 (t)	1.35	1.35	1.35	1.35	1.35
掛数	4	4	4	4	4

HD性能 22.7mブーム+9.4m+27mヘビーリフトジブ

オフセット	10°	20°	30°	45°	60°
作業半径 (m)	荷重 (ton)	荷重 (ton)	荷重 (ton)	荷重 (ton)	荷重 (ton)
14.0	47.4				
16.0	37.5				
18.0	30.3	33.4			
20.0	25.0	27.6			
22.0	20.7	23.1	25.3		
24.0	17.3	19.4	21.4		
26.0	14.6	16.4	18.1	20.5	
28.0	12.2	13.9	15.4	17.5	
30.0	10.3	11.7	13.1	15.0	16.5
32.0	8.6	9.9	11.1	12.8	14.1
34.0	7.1	8.3	9.4	10.9	11.9
36.0	5.5	6.9	7.9	9.2	10.0
38.0	4.0	5.4	6.5	7.6	8.3
40.0			5.0	6.2	6.7
42.0				4.7	
危険角度 (°)	52	56	56	56	60
フック種類	83t	83t	83t	83t	83t
フック質量 (t)	1.35	1.35	1.35	1.35	1.35
掛数	6	6	6	6	6

HD性能 31.8mブーム+9.4m+27mヘビーリフトジブ

オフセット	10°	20°	30°	45°	60°
作業半径 (m)	荷重 (ton)	荷重 (ton)	荷重 (ton)	荷重 (ton)	荷重 (ton)
16.0	36.7				
18.0	29.5				
20.0	24.1	27.0			
22.0	19.9	22.4			
24.0	16.5	18.8	20.9		
26.0	13.7	15.7	17.7		
28.0	11.4	13.2	14.9	17.2	
30.0	9.4	11.0	12.6	14.7	
32.0	7.7	9.2	10.6	12.5	13.9
34.0	5.9	7.6	8.9	10.5	11.8
36.0	4.2	6.0	7.3	8.8	9.9
38.0		4.4	5.9	7.3	8.2
40.0			4.3	6.0	6.7
42.0				4.3	5.2
危険角度 (°)	61	62	63	63	65
フック種類	83t	83t	83t	83t	83t
フック質量 (t)	1.35	1.35	1.35	1.35	1.35
掛数	4	4	4	4	4

HD性能 40.9mブーム+9.4m+27mヘビーリフトジブ

オフセット	10°	20°	30°	45°	60°
作業半径 (m)	荷重 (ton)	荷重 (ton)	荷重 (ton)	荷重 (ton)	荷重 (ton)
16.0	30.0				
18.0	28.4				
20.0	22.9	26.2			
22.0	18.7	21.6			
24.0	15.3	17.9	20.3		
26.0	12.5	14.8	17.0		
28.0	10.1	12.2	14.2		
30.0	7.8	10.1	11.9	14.3	
32.0		8.2	9.8	12.0	13.6
34.0			8.1	10.0	11.5
36.0			6.4	8.3	9.6
38.0				6.7	7.8
40.0					6.3
危険角度 (°)	70	71	71	72	72
フック種類	83t	83t	83t	83t	83t
フック質量 (t)	1.35	1.35	1.35	1.35	1.35
掛数	4	4	4	4	4

HD性能 22.7mブーム+9.4m+36mヘビーリフトジブ

オフセット	10°	20°	30°	45°	60°
作業半径 (m)	荷重 (ton)	荷重 (ton)	荷重 (ton)	荷重 (ton)	荷重 (ton)
16.0	39.5				
18.0	32.1				
20.0	26.6				
22.0	22.2	25.1			
24.0	18.8	21.3			
26.0	15.9	18.2			
28.0	13.5	15.6	17.6		
30.0	11.5	13.4	15.2		
32.0	9.7	11.5	13.2		
34.0	8.2	9.8	11.4	13.5	
36.0	6.9	8.4	9.8	11.7	
38.0	5.5	7.1	8.4	10.1	11.6
40.0	4.1	5.9	7.1	8.7	10.0
42.0		4.5	6.0	7.4	8.6
44.0			4.7	6.2	7.2
46.0				5.1	5.9
48.0					4.7
危険角度 (°)	57	60	61	64	64
フック種類	83t	83t	83t	83t	83t
フック質量 (t)	1.35	1.35	1.35	1.35	1.35
掛数	4	4	4	4	4

HD性能 40.9mブーム+9.4m+36mヘビーリフトジブ

オフセット	10°	20°	30°	45°	60°
作業半径 (m)	荷重 (ton)	荷重 (ton)	荷重 (ton)	荷重 (ton)	荷重 (ton)
20.0	24.0				
22.0	20.3				
24.0	16.8				
26.0	13.8	16.9			
28.0	11.3	14.2			
30.0	9.1	11.9	14.3		
32.0		9.9	12.1		
34.0		8.1	10.2		
36.0			8.6	11.1	
38.0			7.1	9.4	
40.0				7.9	
42.0				6.6	8.1
44.0					6.7
46.0					5.5
危険角度 (°)	73	74	75	76	76
フック種類	83t	83t	83t	83t	83t
フック質量 (t)	1.35	1.35	1.35	1.35	1.35
掛数	4	4	4	4	4

HD性能 31.8mブーム+9.4m+36mヘビーリフトジブ

オフセット	10°	20°	30°	45°	60°
作業半径 (m)	荷重 (ton)	荷重 (ton)	荷重 (ton)	荷重 (ton)	荷重 (ton)
18.0	31.7				
20.0	26.1				
22.0	21.7				
24.0	18.2	21.1			
26.0	15.3	17.9			
28.0	12.9	15.3	17.5		
30.0	10.9	13.0	15.1		
32.0	9.1	11.1	13.0		
34.0	7.6	9.4	11.1		
36.0	6.1	7.9	9.5	11.7	
38.0		6.6	8.1	10.1	
40.0		5.2	6.8	8.6	10.1
42.0			5.6	7.3	8.6
44.0			4.2	6.1	7.2
46.0				4.9	6.0
48.0					4.8
危険角度 (°)	65	66	67	68	69
フック種類	83t	83t	83t	83t	83t
フック質量 (t)	1.35	1.35	1.35	1.35	1.35
掛数	4	4	4	4	4

HD性能 50.0mブーム+9.4m+36mヘビーリフトジブ

オフセット	10°	20°	30°	45°	60°
作業半径 (m)	荷重 (ton)	荷重 (ton)	荷重 (ton)	荷重 (ton)	荷重 (ton)
20.0	18.0				
22.0	18.0				
24.0	15.9				
26.0	13.0	16.9			
28.0	10.5	14.1			
30.0		11.7			
32.0		9.5	12.2		
34.0		7.6	10.3		
36.0			8.4		
38.0			6.7	9.6	
40.0				8.1	
42.0				6.6	8.3
44.0					7.0
46.0					5.6
危険角度 (°)	76	76	77	78	78
フック種類	24t	24t	24t	24t	24t
フック質量 (t)	0.88	0.88	0.88	0.88	0.88
掛数	2	2	2	2	2

HA性能 22.7mブーム+9.4m+36mヘビーリフトジブ

オフセット	10°	20°	30°	45°	60°
作業半径 (m)	荷重 (ton)	荷重 (ton)	荷重 (ton)	荷重 (ton)	荷重 (ton)
16.0	45.0				
18.0	45.0				
20.0	45.0				
22.0	45.0	42.9			
24.0	40.9	41.4			
26.0	36.5	39.1			
28.0	32.7	35.3	32.8		
30.0	29.4	31.8	31.4		
32.0	26.5	28.7	30.1		
34.0	23.8	25.9	27.9	25.3	
36.0	21.4	23.4	25.3	24.6	
38.0	19.2	21.1	22.8	24.0	21.5
40.0	17.3	19.0	20.6	22.8	21.1
42.0	15.5	17.1	18.5	20.5	20.7
44.0	13.9	15.3	16.7	18.5	19.8
46.0	12.4	13.8	15.0	16.6	17.7
48.0	11.1	12.3	13.4	14.9	15.7
50.0	9.9	11.0	12.0	13.2	13.8
55.0	7.2	8.0	8.7	9.5	
60.0	4.9	5.5	5.9		
危険角度 (°)	25	25	30	45	60
フック種類	83t	83t	83t	83t	83t
フック質量 (t)	1.35	1.35	1.35	1.35	1.35
掛数	4	4	4	4	4

HA性能 40.9mブーム+9.4m+36mヘビーリフトジブ

オフセット	10°	20°	30°	45°	60°
作業半径 (m)	荷重 (ton)	荷重 (ton)	荷重 (ton)	荷重 (ton)	荷重 (ton)
20.0	24.0				
22.0	24.0				
24.0	24.0				
26.0	24.0	24.0			
28.0	24.0	24.0			
30.0	24.0	24.0	24.0		
32.0	22.5	24.0	24.0		
34.0	20.4	22.4	24.0		
36.0	18.4	20.4	22.1	24.0	
38.0	16.2	18.5	20.1	22.1	
40.0	14.2	16.6	18.3	20.0	
42.0	12.4	14.6	16.6	18.0	18.9
44.0	10.8	12.9	14.7	16.3	17.0
46.0	9.3	11.2	13.0	14.8	15.3
48.0	8.0	9.7	11.4	13.2	13.7
50.0	6.7	8.4	9.9	11.7	12.0
55.0	3.9	5.4	6.6	8.2	8.5
60.0			3.9	5.1	
危険角度 (°)	50	53	53	55	60
フック種類	83t	83t	83t	83t	83t
フック質量 (t)	1.35	1.35	1.35	1.35	1.35
掛数	4	4	4	4	4

HA性能 31.8mブーム+9.4m+36mヘビーリフトジブ

オフセット	10°	20°	30°	45°	60°
作業半径 (m)	荷重 (ton)	荷重 (ton)	荷重 (ton)	荷重 (ton)	荷重 (ton)
18.0	32.0				
20.0	32.0				
22.0	32.0				
24.0	32.0	32.0			
26.0	32.0	32.0			
28.0	32.0	32.0	32.0		
30.0	28.6	31.3	32.0		
32.0	25.7	28.2	30.5		
34.0	22.9	25.4	27.6		
36.0	20.5	22.7	24.9	25.0	
38.0	18.3	20.4	22.4	24.4	
40.0	16.3	18.3	20.1	22.6	21.5
42.0	14.6	16.4	18.1	20.3	21.1
44.0	12.9	14.6	16.2	18.3	19.7
46.0	11.5	13.0	14.5	16.4	17.7
48.0	10.1	11.6	12.9	14.6	15.8
50.0	8.8	10.2	11.4	13.0	13.9
55.0	6.1	7.2	8.2	9.4	
60.0	3.8	4.7	5.5	6.2	
危険角度 (°)	40	40	43	45	60
フック種類	83t	83t	83t	83t	83t
フック質量 (t)	1.35	1.35	1.35	1.35	1.35
掛数	4	4	4	4	4

HA性能 50.0mブーム+9.4m+36mヘビーリフトジブ

オフセット	10°	20°	30°	45°	60°
作業半径 (m)	荷重 (ton)	荷重 (ton)	荷重 (ton)	荷重 (ton)	荷重 (ton)
20.0	18.0				
22.0	18.0				
24.0	18.0				
26.0	18.0	18.0			
28.0	18.0	18.0			
30.0	18.0	18.0			
32.0	18.0	18.0	18.0		
34.0	16.8	18.0	18.0		
36.0	15.3	17.0	18.0		
38.0	13.8	15.4	16.9	18.0	
40.0	12.5	13.9	15.2	17.0	
42.0	11.2	12.6	13.8	15.4	16.4
44.0	10.0	11.3	12.4	13.9	14.7
46.0	8.9	10.1	11.1	12.4	13.2
48.0	7.6	9.0	9.9	11.1	11.7
50.0	6.4	7.9	8.8	9.8	10.3
55.0	3.6	5.2	6.3	7.0	7.1
60.0		2.6	3.8	4.5	4.3
危険角度 (°)	55	56	58	60	60
フック種類	24t	24t	24t	24t	24t
フック質量 (t)	0.88	0.88	0.88	0.88	0.88
掛数	2	2	2	2	2

HB性能 22.7mブーム+9.4m+36mヘビーリフトジブ

オフセット	10°	20°	30°	45°	60°
作業半径 (m)	荷重 (ton)	荷重 (ton)	荷重 (ton)	荷重 (ton)	荷重 (ton)
16.0	45.0				
18.0	45.0				
20.0	41.0				
22.0	35.5	38.5			
24.0	30.7	33.3			
26.0	26.7	29.1			
28.0	23.4	25.5	27.6		
30.0	20.6	22.5	24.4		
32.0	18.1	19.9	21.6		
34.0	16.0	17.7	19.2	21.4	
36.0	14.0	15.7	17.1	19.1	
38.0	12.2	14.0	15.3	17.1	18.6
40.0	10.6	12.3	13.6	15.2	16.6
42.0	9.2	10.8	12.1	13.6	14.7
44.0	7.9	9.3	10.7	12.1	13.1
46.0	6.7	8.0	9.2	10.7	11.5
48.0	5.6	6.8	7.9	9.3	10.0
50.0	4.6	5.7	6.7	7.9	8.5
55.0				4.6	
危険角度 (°)	45	46	49	49	60
フック種類	83t	83t	83t	83t	83t
フック質量 (t)	1.35	1.35	1.35	1.35	1.35
掛数	4	4	4	4	4

HB性能 40.9mブーム+9.4m+36mヘビーリフトジブ

オフセット	10°	20°	30°	45°	60°
作業半径 (m)	荷重 (ton)	荷重 (ton)	荷重 (ton)	荷重 (ton)	荷重 (ton)
20.0	24.0				
22.0	24.0				
24.0	24.0				
26.0	24.0	24.0			
28.0	20.9	24.0			
30.0	18.0	21.0	23.4		
32.0	15.4	18.4	20.6		
34.0	13.1	16.0	18.1		
36.0	11.1	13.7	15.9	18.5	
38.0	9.3	11.7	14.0	16.3	
40.0	7.6	9.9	12.1	14.5	
42.0	6.1	8.3	10.3	12.7	14.3
44.0	4.8	6.8	8.7	11.2	12.6
46.0		5.5	7.2	9.5	11.0
48.0		4.2	5.9	8.0	9.4
50.0			4.6	6.5	7.8
危険角度 (°)	62	62	64	68	68
フック種類	83t	83t	83t	83t	83t
フック質量 (t)	1.35	1.35	1.35	1.35	1.35
掛数	4	4	4	4	4

HB性能 31.8mブーム+9.4m+36mヘビーリフトジブ

オフセット	10°	20°	30°	45°	60°
作業半径 (m)	荷重 (ton)	荷重 (ton)	荷重 (ton)	荷重 (ton)	荷重 (ton)
18.0	32.0				
20.0	32.0				
22.0	32.0				
24.0	30.2	32.0			
26.0	26.1	28.8			
28.0	22.8	25.2	27.4		
30.0	19.9	22.1	24.2		
32.0	17.4	19.5	21.4		
34.0	15.1	17.2	19.0		
36.0	13.1	15.3	16.9	19.1	
38.0	11.3	13.4	15.0	17.0	
40.0	9.7	11.7	13.3	15.1	16.6
42.0	8.3	10.1	11.8	13.5	14.8
44.0	6.9	8.6	10.2	11.9	13.1
46.0	5.7	7.3	8.7	10.5	11.5
48.0	4.6	6.0	7.4	9.1	10.1
50.0		4.9	6.1	7.7	8.8
55.0				4.5	
危険角度 (°)	54	56	58	58	60
フック種類	83t	83t	83t	83t	83t
フック質量 (t)	1.35	1.35	1.35	1.35	1.35
掛数	4	4	4	4	4

HB性能 50.0mブーム+9.4m+36mヘビーリフトジブ

オフセット	10°	20°	30°	45°	60°
作業半径 (m)	荷重 (ton)	荷重 (ton)	荷重 (ton)	荷重 (ton)	荷重 (ton)
20.0	18.0				
22.0	18.0				
24.0	18.0				
26.0	18.0	18.0			
28.0	18.0	18.0			
30.0	17.8	18.0			
32.0	15.2	18.0	18.0		
34.0	12.9	15.9	18.0		
36.0	10.8	13.7	16.0		
38.0	9.0	11.7	14.1	16.5	
40.0	7.4	9.8	12.1	14.6	
42.0	5.9	8.2	10.3	12.9	14.5
44.0		6.7	8.7	11.3	12.8
46.0		5.3	7.2	9.7	11.2
48.0		4.1	5.8	8.1	9.7
50.0			4.6	6.7	8.1
55.0				3.5	4.5
危険角度 (°)	66	66	67	68	68
フック種類	24t	24t	24t	24t	24t
フック質量 (t)	0.88	0.88	0.88	0.88	0.88
掛数	2	2	2	2	2

HC性能 22.7mブーム+9.4m+36mヘビーリフトジブ

オフセット	10°	20°	30°	45°	60°
作業半径 (m)	荷重 (ton)	荷重 (ton)	荷重 (ton)	荷重 (ton)	荷重 (ton)
16.0	45.0				
18.0	38.9				
20.0	33.1				
22.0	28.3	31.2			
24.0	24.3	26.9			
26.0	20.9	23.2			
28.0	18.0	20.2	22.3		
30.0	15.5	17.6	19.5		
32.0	13.3	15.4	17.1		
34.0	11.3	13.5	15.1	17.2	
36.0	9.6	11.6	13.2	15.2	
38.0	8.1	9.9	11.6	13.4	14.9
40.0	6.7	8.4	10.0	11.8	13.1
42.0	5.4	7.0	8.5	10.3	11.4
44.0	4.3	5.7	7.1	8.9	9.9
46.0		4.5	5.8	7.4	8.5
48.0			4.6	6.0	6.8
50.0				4.7	5.3
危険角度 (°)	53	55	56	58	60
フック種類	83t	83t	83t	83t	83t
フック質量 (t)	1.35	1.35	1.35	1.35	1.35
掛数	4	4	4	4	4

HC性能 40.9mブーム+9.4m+36mヘビーリフトジブ

オフセット	10°	20°	30°	45°	60°
作業半径 (m)	荷重 (ton)	荷重 (ton)	荷重 (ton)	荷重 (ton)	荷重 (ton)
20.0	24.0				
22.0	24.0				
24.0	21.7				
26.0	18.2	21.9			
28.0	15.2	18.8			
30.0	12.7	16.0	18.5		
32.0	10.4	13.5	16.1		
34.0	8.4	11.3	13.9		
36.0	6.7	9.3	11.8	14.5	
38.0		7.6	9.9	12.7	
40.0		6.0	8.1	11.0	
42.0			6.5	9.2	11.0
44.0			5.1	7.6	9.4
46.0				6.1	7.7
48.0				4.7	6.1
50.0					4.6
危険角度 (°)	68	69	70	70	71
フック種類	83t	83t	83t	83t	83t
フック質量 (t)	1.35	1.35	1.35	1.35	1.35
掛数	4	4	4	4	4

HC性能 31.8mブーム+9.4m+36mヘビーリフトジブ

オフセット	10°	20°	30°	45°	60°
作業半径 (m)	荷重 (ton)	荷重 (ton)	荷重 (ton)	荷重 (ton)	荷重 (ton)
18.0	32.0				
20.0	32.0				
22.0	27.6				
24.0	23.5	26.6			
26.0	20.1	23.0			
28.0	17.2	19.9	22.1		
30.0	14.7	17.3	19.3		
32.0	12.4	15.0	16.9		
34.0	10.5	12.9	14.8		
36.0	8.7	11.0	13.0	15.1	
38.0	7.2	9.2	11.2	13.3	
40.0	5.7	7.7	9.5	11.7	13.1
42.0	4.5	6.3	8.0	10.2	11.5
44.0		5.0	6.6	8.6	10.0
46.0			5.3	7.2	8.5
48.0			4.1	5.8	6.9
50.0				4.5	5.5
危険角度 (°)	60	62	62	64	64
フック種類	83t	83t	83t	83t	83t
フック質量 (t)	1.35	1.35	1.35	1.35	1.35
掛数	4	4	4	4	4

HC性能 50.0mブーム+9.4m+36mヘビーリフトジブ

オフセット	10°	20°	30°	45°	60°
作業半径 (m)	荷重 (ton)	荷重 (ton)	荷重 (ton)	荷重 (ton)	荷重 (ton)
20.0	18.0				
22.0	18.0				
24.0	18.0				
26.0	18.0	18.0			
28.0	15.1	18.0			
30.0	12.5	16.0			
32.0	10.2	13.5	16.2		
34.0	8.2	11.2	14.0		
36.0	6.4	9.3	11.9		
38.0		7.5	9.9	12.9	
40.0		5.9	8.2	11.1	
42.0			6.6	9.4	11.2
44.0				7.7	9.7
46.0				6.2	8.0
48.0				4.8	6.4
50.0					4.9
危険角度 (°)	71	72	73	73	74
フック種類	24t	24t	24t	24t	24t
フック質量 (t)	0.88	0.88	0.88	0.88	0.88
掛数	2	2	2	2	2

HA性能 22.7mブーム+9.4m+45mヘビーリフトジブ

オフセット	10°	20°	30°	45°	60°
作業半径 (m)	荷重 (ton)	荷重 (ton)	荷重 (ton)	荷重 (ton)	荷重 (ton)
20.0	32.0				
22.0	32.0				
24.0	32.0				
26.0	32.0	32.0			
28.0	32.0	32.0			
30.0	30.7	30.6			
32.0	27.7	29.0	25.7		
34.0	25.1	27.6	24.7		
36.0	22.7	25.1	23.7		
38.0	20.5	22.7	22.7		
40.0	18.5	20.6	21.9	19.2	
42.0	16.7	18.7	20.5	18.6	
44.0	15.1	16.9	18.7	18.0	
46.0	13.6	15.3	16.9	17.6	15.6
48.0	12.2	13.8	15.3	17.1	15.3
50.0	11.0	12.5	13.9	15.8	15.0
55.0	8.2	9.5	10.6	12.2	13.2
60.0	5.9	6.9	7.8	9.0	
65.0	4.0	4.7	5.4	6.0	
危険角度 (°)	30	35	35	45	60
フック種類	83t	83t	83t	83t	83t
フック質量 (t)	1.35	1.35	1.35	1.35	1.35
掛数	4	4	4	4	4

HA性能 40.9mブーム+9.4m+45mヘビーリフトジブ

オフセット	10°	20°	30°	45°	60°
作業半径 (m)	荷重 (ton)	荷重 (ton)	荷重 (ton)	荷重 (ton)	荷重 (ton)
22.0	18.0				
24.0	18.0				
26.0	18.0				
28.0	18.0				
30.0	18.0	18.0			
32.0	18.0	18.0			
34.0	18.0	18.0			
36.0	18.0	18.0	18.0		
38.0	17.3	18.0	18.0		
40.0	15.7	17.6	18.0		
42.0	13.9	16.0	17.6		
44.0	12.3	14.7	16.1	18.0	
46.0	10.7	13.1	14.7	16.5	
48.0	9.3	11.6	13.4	15.1	
50.0	8.1	10.2	12.1	13.7	14.6
55.0	5.2	7.1	8.7	10.4	10.9
60.0	2.9	4.5	5.9	7.5	7.8
65.0			3.5	4.9	5.0
危険角度 (°)	52	56	56	60	60
フック種類	24t	24t	24t	24t	24t
フック質量 (t)	0.88	0.88	0.88	0.88	0.88
掛数	2	2	2	2	2

HA性能 31.8mブーム+9.4m+45mヘビーリフトジブ

オフセット	10°	20°	30°	45°	60°
作業半径 (m)	荷重 (ton)	荷重 (ton)	荷重 (ton)	荷重 (ton)	荷重 (ton)
22.0	24.0				
24.0	24.0				
26.0	24.0				
28.0	24.0	24.0			
30.0	24.0	24.0			
32.0	24.0	24.0			
34.0	23.9	24.0	24.0		
36.0	21.4	24.0	24.0		
38.0	19.2	21.7	23.4		
40.0	17.2	19.6	21.9		
42.0	15.4	17.6	19.8	18.8	
44.0	13.8	15.9	17.9	18.3	
46.0	12.3	14.3	16.1	17.9	
48.0	10.9	12.8	14.5	17.0	15.5
50.0	9.6	11.4	13.0	15.3	15.3
55.0	6.9	8.4	9.8	11.6	13.0
60.0	4.6	5.8	7.0	8.5	9.4
65.0			4.6	5.7	
危険角度 (°)	47	50	50	53	60
フック種類	83t	83t	83t	83t	83t
フック質量 (t)	1.35	1.35	1.35	1.35	1.35
掛数	4	4	4	4	4

HA性能 50.0mブーム+9.4m+45mヘビーリフトジブ

オフセット	10°	20°	30°	45°	60°
作業半径 (m)	荷重 (ton)	荷重 (ton)	荷重 (ton)	荷重 (ton)	荷重 (ton)
24.0	12.0				
26.0	12.0				
28.0	12.0				
30.0	12.0	12.0			
32.0	12.0	12.0			
34.0	12.0	12.0			
36.0	12.0	12.0			
38.0	12.0	12.0	12.0		
40.0	12.0	12.0	12.0		
42.0	10.8	12.0	12.0		
44.0	9.7	11.2	12.0		
46.0	8.7	10.0	11.3	12.0	
48.0	7.7	9.0	10.2	11.8	
50.0	6.8	8.0	9.0	10.5	11.7
55.0	4.4	5.7	6.6	7.7	8.6
60.0		3.7	4.5	5.3	5.8
65.0			2.5	3.1	3.2
危険角度 (°)	60	60	60	63	65
フック種類	24t	24t	24t	24t	24t
フック質量 (t)	0.88	0.88	0.88	0.88	0.88
掛数	2	2	2	2	2

HD性能 22.7mブーム+9.4m+45mヘビーリフトジブ

オフセット	10°	20°	30°	45°	60°
作業半径 (m)	荷重 (ton)	荷重 (ton)	荷重 (ton)	荷重 (ton)	荷重 (ton)
20.0	28.2				
22.0	23.7				
24.0	20.2				
26.0	17.2	19.9			
28.0	14.8	17.2			
30.0	12.7	14.9			
32.0	10.9	13.0	15.0		
34.0	9.3	11.3	13.1		
36.0	8.0	9.7	11.5		
38.0	6.8	8.4	10.0		
40.0	5.6	7.2	8.7	10.8	
42.0	4.3	6.1	7.5	9.5	
44.0		5.1	6.5	8.3	
46.0			5.5	7.2	8.6
48.0			4.4	6.1	7.4
50.0				5.2	6.4
危険角度 (°)	67	64	65	70	74
フック種類	83t	83t	83t	83t	83t
フック質量 (t)	1.35	1.35	1.35	1.35	1.35
掛数	4	4	4	4	4

HD性能 40.9mブーム+9.4m+45mヘビーリフトジブ

オフセット	10°	20°	30°	45°	60°
作業半径 (m)	荷重 (ton)	荷重 (ton)	荷重 (ton)	荷重 (ton)	荷重 (ton)
22.0	18.0				
24.0	18.0				
26.0	15.4				
28.0	12.7				
30.0	10.5	13.8			
32.0	8.5	11.8			
34.0		10.0			
36.0		8.3	10.7		
38.0		6.7	9.1		
40.0			7.8		
42.0			6.4		
44.0				7.7	
46.0				6.6	
48.0				5.5	
50.0					6.0
危険角度 (°)	74	75	76	78	78
フック種類	24t	24t	24t	24t	24t
フック質量 (t)	0.88	0.88	0.88	0.88	0.88
掛数	2	2	2	2	2

HD性能 31.8mブーム+9.4m+45mヘビーリフトジブ

オフセット	10°	20°	30°	45°	60°
作業半径 (m)	荷重 (ton)	荷重 (ton)	荷重 (ton)	荷重 (ton)	荷重 (ton)
22.0	22.9				
24.0	19.3				
26.0	16.4				
28.0	13.9	16.7			
30.0	11.8	14.3			
32.0	10.0	12.4			
34.0	8.4	10.6	12.7		
36.0	7.1	9.1	11.0		
38.0		7.7	9.5		
40.0		6.5	8.2		
42.0		5.3	7.0	9.2	
44.0			5.9	8.0	
46.0				6.8	
48.0				5.8	7.3
50.0				4.8	6.2
危険角度 (°)	69	70	72	73	75
フック種類	83t	83t	83t	83t	83t
フック質量 (t)	1.35	1.35	1.35	1.35	1.35
掛数	4	4	4	4	4

HD性能 50.0mブーム+9.4m+45mヘビーリフトジブ

オフセット	10°	20°	30°	45°	60°
作業半径 (m)	荷重 (ton)	荷重 (ton)	荷重 (ton)	荷重 (ton)	荷重 (ton)
24.0	12.0				
26.0	12.0				
28.0	11.4				
30.0		12.0			
32.0		11.0			
34.0		9.0			
36.0					
38.0			8.7		
40.0					
42.0					
44.0					
46.0				6.2	
48.0					
50.0					5.9
危険角度 (°)	78	79	80	81	81
フック種類	24t	24t	24t	24t	24t
フック質量 (t)	0.88	0.88	0.88	0.88	0.88
掛数	2	2	2	2	2

HB性能 22.7mブーム+9.4m+45mヘビーリフトジブ

オフセット	10°	20°	30°	45°	60°
作業半径 (m)	荷重 (ton)	荷重 (ton)	荷重 (ton)	荷重 (ton)	荷重 (ton)
20.0	32.0				
22.0	32.0				
24.0	32.0				
26.0	28.1	30.8			
28.0	24.7	27.2			
30.0	21.8	24.1			
32.0	19.3	21.4	23.5		
34.0	17.2	19.1	21.0		
36.0	15.3	17.1	18.9		
38.0	13.5	15.3	17.0		
40.0	11.9	13.7	15.2	17.4	
42.0	10.4	12.3	13.7	15.7	
44.0	9.1	10.9	12.3	14.2	
46.0	7.8	9.5	11.0	12.8	14.2
48.0	6.7	8.3	9.8	11.5	12.8
50.0	5.7	7.2	8.6	10.3	11.4
55.0		4.6	5.8	7.4	8.4
60.0				4.6	
危険角度 (°)	53	53	56	56	60
フック種類	83t	83t	83t	83t	83t
フック質量 (t)	1.35	1.35	1.35	1.35	1.35
掛数	4	4	4	4	4

HB性能 40.9mブーム+9.4m+45mヘビーリフトジブ

オフセット	10°	20°	30°	45°	60°
作業半径 (m)	荷重 (ton)	荷重 (ton)	荷重 (ton)	荷重 (ton)	荷重 (ton)
22.0	18.0				
24.0	18.0				
26.0	18.0				
28.0	18.0				
30.0	18.0	18.0			
32.0	17.0	18.0			
34.0	14.7	17.9			
36.0	12.6	15.8	18.0		
38.0	10.8	13.8	16.1		
40.0	9.1	11.9	14.3		
42.0	7.6	10.3	12.7		
44.0	6.2	8.7	11.1	13.6	
46.0	5.0	7.3	9.6	12.2	
48.0	3.8	6.0	8.1	10.8	
50.0		4.9	6.8	9.5	11.1
55.0			3.9	6.2	7.8
60.0				3.3	4.5
危険角度 (°)	63	64	65	66	66
フック種類	24t	24t	24t	24t	24t
フック質量 (t)	0.88	0.88	0.88	0.88	0.88
掛数	2	2	2	2	2

HB性能 31.8mブーム+9.4m+45mヘビーリフトジブ

オフセット	10°	20°	30°	45°	60°
作業半径 (m)	荷重 (ton)	荷重 (ton)	荷重 (ton)	荷重 (ton)	荷重 (ton)
22.0	24.0				
24.0	24.0				
26.0	24.0				
28.0	23.8	24.0			
30.0	20.9	23.5			
32.0	18.4	20.8			
34.0	16.1	18.5	20.6		
36.0	14.0	16.4	18.4		
38.0	12.2	14.6	16.5		
40.0	10.6	13.0	14.7		
42.0	9.1	11.3	13.2	15.4	
44.0	7.7	9.9	11.8	13.8	
46.0	6.5	8.5	10.4	12.4	
48.0	5.4	7.2	9.0	11.1	12.6
50.0	4.3	6.1	7.7	9.9	11.3
55.0			5.0	6.8	8.2
60.0				4.1	5.0
危険角度 (°)	58	63	63	63	63
フック種類	83t	83t	83t	83t	83t
フック質量 (t)	1.35	1.35	1.35	1.35	1.35
掛数	4	4	4	4	4

HB性能 50.0mブーム+9.4m+45mヘビーリフトジブ

オフセット	10°	20°	30°	45°	60°
作業半径 (m)	荷重 (ton)	荷重 (ton)	荷重 (ton)	荷重 (ton)	荷重 (ton)
24.0	12.0				
26.0	12.0				
28.0	12.0				
30.0	12.0	12.0			
32.0	12.0	12.0			
34.0	12.0	12.0			
36.0	11.9	12.0			
38.0	10.0	12.0	12.0		
40.0	8.3	11.4	12.0		
42.0	6.8	9.7	12.0		
44.0	5.4	8.1	10.7		
46.0		6.7	9.1	12.0	
48.0		5.4	7.7	10.6	
50.0			6.3	9.2	11.0
55.0				5.9	7.7
60.0					4.5
危険角度 (°)	69	70	70	71	72
フック種類	24t	24t	24t	24t	24t
フック質量 (t)	0.88	0.88	0.88	0.88	0.88
掛数	2	2	2	2	2

HC性能 22.7mブーム+9.4m+45mヘビーリフトジブ

オフセット	10°	20°	30°	45°	60°
作業半径 (m)	荷重 (ton)	荷重 (ton)	荷重 (ton)	荷重 (ton)	荷重 (ton)
20.0	32.0				
22.0	29.9				
24.0	25.7				
26.0	22.3	24.9			
28.0	19.4	21.8			
30.0	16.9	19.2			
32.0	14.6	16.9	18.9		
34.0	12.7	15.0	16.8		
36.0	10.9	13.2	15.0		
38.0	9.3	11.6	13.3		
40.0	7.9	10.0	11.8	13.9	
42.0	6.6	8.6	10.4	12.4	
44.0	5.5	7.3	9.0	11.0	
46.0	4.4	6.1	7.7	9.8	11.2
48.0		5.0	6.5	8.6	9.9
50.0		4.0	5.4	7.4	8.7
55.0				4.5	5.5
危険角度 (°)	57	58	63	63	63
フック種類	83t	83t	83t	83t	83t
フック質量 (t)	1.35	1.35	1.35	1.35	1.35
掛数	4	4	4	4	4

HC性能 40.9mブーム+9.4m+45mヘビーリフトジブ

オフセット	10°	20°	30°	45°	60°
作業半径 (m)	荷重 (ton)	荷重 (ton)	荷重 (ton)	荷重 (ton)	荷重 (ton)
22.0	18.0				
24.0	18.0				
26.0	18.0				
28.0	17.0				
30.0	14.4	18.0			
32.0	12.1	15.7			
34.0	10.0	13.5			
36.0	8.2	11.4	14.2		
38.0	6.6	9.6	12.4		
40.0	5.2	8.0	10.7		
42.0		6.5	9.0		
44.0		5.1	7.5	10.5	
46.0			6.1	9.2	
48.0			4.8	7.7	
50.0				6.3	8.4
55.0					4.9
危険角度 (°)	69	71	72	73	73
フック種類	24t	24t	24t	24t	24t
フック質量 (t)	0.88	0.88	0.88	0.88	0.88
掛数	2	2	2	2	2

HC性能 31.8mブーム+9.4m+45mヘビーリフトジブ

オフセット	10°	20°	30°	45°	60°
作業半径 (m)	荷重 (ton)	荷重 (ton)	荷重 (ton)	荷重 (ton)	荷重 (ton)
22.0	24.0				
24.0	24.0				
26.0	21.2				
28.0	18.3	21.2			
30.0	15.7	18.6			
32.0	13.4	16.3			
34.0	11.4	14.3	16.4		
36.0	9.6	12.4	14.5		
38.0	8.0	10.6	12.8		
40.0	6.6	9.0	11.3		
42.0	5.3	7.6	9.7	12.1	
44.0	4.1	6.2	8.3	10.7	
46.0		5.0	6.9	9.4	
48.0			5.7	8.1	9.7
50.0			4.6	6.9	8.5
55.0					5.3
危険角度 (°)	63	66	67	68	71
フック種類	83t	83t	83t	83t	83t
フック質量 (t)	1.35	1.35	1.35	1.35	1.35
掛数	4	4	4	4	4

HC性能 50.0mブーム+9.4m+45mヘビーリフトジブ

オフセット	10°	20°	30°	45°	60°
作業半径 (m)	荷重 (ton)	荷重 (ton)	荷重 (ton)	荷重 (ton)	荷重 (ton)
24.0	12.0				
26.0	12.0				
28.0	12.0				
30.0	12.0	12.0			
32.0	11.3	12.0			
34.0	9.3	12.0			
36.0	7.5	10.9			
38.0		9.0	12.0		
40.0		7.4	10.2		
42.0			8.6		
44.0			7.0		
46.0				8.9	
48.0				7.4	
50.0				6.0	8.3
55.0					4.8
危険角度 (°)	74	75	76	77	77
フック種類	24t	24t	24t	24t	24t
フック質量 (t)	0.88	0.88	0.88	0.88	0.88
掛数	2	2	2	2	2

HA性能 22.7mブーム+9.4m+54mヘビーリフトジブ

オフセット	10°	20°	30°	45°	60°
作業半径 (m)	荷重 (ton)	荷重 (ton)	荷重 (ton)	荷重 (ton)	荷重 (ton)
24.0	12.0				
26.0	12.0				
28.0	12.0				
30.0	12.0				
32.0	12.0	12.0			
34.0	12.0	12.0			
36.0	12.0	12.0			
38.0	12.0	12.0			
40.0	12.0	12.0	12.0		
42.0	12.0	12.0	12.0		
44.0	12.0	12.0	12.0		
46.0	12.0	12.0	12.0		
48.0	12.0	12.0	11.8	10.4	
50.0	12.0	12.0	11.4	10.1	
55.0	10.8	11.1	10.4	9.4	8.9
60.0	8.4	9.7	9.5	8.8	8.5
65.0	6.4	7.5	8.6	8.3	8.2
70.0	4.7	5.6	6.4	7.4	
75.0	3.1	3.8	4.4	4.9	
80.0	1.7	2.2	2.4		
危険角度 (°)	20	20	30	45	60
フック種類	12t	12t	12t	12t	12t
フック質量 (t)	0.53	0.53	0.53	0.53	0.53
掛数	1	1	1	1	1

HA性能 40.9mブーム+9.4m+54mヘビーリフトジブ

オフセット	10°	20°	30°	45°	60°
作業半径 (m)	荷重 (ton)	荷重 (ton)	荷重 (ton)	荷重 (ton)	荷重 (ton)
26.0	12.0				
28.0	12.0				
30.0	12.0				
32.0	12.0				
34.0	12.0	12.0			
36.0	12.0	12.0			
38.0	12.0	12.0			
40.0	12.0	12.0			
42.0	12.0	12.0	12.0		
44.0	12.0	12.0	12.0		
46.0	12.0	12.0	12.0		
48.0	11.8	12.0	12.0		
50.0	10.5	12.0	12.0		
55.0	7.6	9.8	11.5	9.9	
60.0	5.2	7.1	8.9	9.3	8.7
65.0	3.2	4.9	6.5	8.6	8.4
70.0	1.5	2.9	4.3	6.1	7.2
75.0			2.4	3.8	4.5
80.0				1.7	
危険角度 (°)	57	55	55	55	60
フック種類	12t	12t	12t	12t	12t
フック質量 (t)	0.53	0.53	0.53	0.53	0.53
掛数	1	1	1	1	1

HA性能 31.8mブーム+9.4m+54mヘビーリフトジブ

オフセット	10°	20°	30°	45°	60°
作業半径 (m)	荷重 (ton)	荷重 (ton)	荷重 (ton)	荷重 (ton)	荷重 (ton)
24.0	12.0				
26.0	12.0				
28.0	12.0				
30.0	12.0				
32.0	12.0	12.0			
34.0	12.0	12.0			
36.0	12.0	12.0			
38.0	12.0	12.0			
40.0	12.0	12.0	12.0		
42.0	12.0	12.0	12.0		
44.0	12.0	12.0	12.0		
46.0	12.0	12.0	12.0		
48.0	12.0	12.0	12.0		
50.0	12.0	12.0	11.9	10.3	
55.0	9.5	11.3	11.0	9.6	
60.0	7.2	8.7	10.1	9.1	8.6
65.0	5.2	6.5	7.8	8.6	8.3
70.0	3.4	4.6	5.7	7.0	7.8
75.0	1.9	2.9	3.8	4.8	
80.0			2.0	2.6	
危険角度 (°)	40	44	44	45	60
フック種類	12t	12t	12t	12t	12t
フック質量 (t)	0.53	0.53	0.53	0.53	0.53
掛数	1	1	1	1	1

HA性能 50.0mブーム+9.4m+54mヘビーリフトジブ

オフセット	10°	20°	30°	45°	60°
作業半径 (m)	荷重 (ton)	荷重 (ton)	荷重 (ton)	荷重 (ton)	荷重 (ton)
26.0	9.0				
28.0	9.0				
30.0	9.0				
32.0	9.0				
34.0	9.0				
36.0	9.0	9.0			
38.0	9.0	9.0			
40.0	9.0	9.0			
42.0	9.0	9.0			
44.0	9.0	9.0	9.0		
46.0	9.0	9.0	9.0		
48.0	9.0	9.0	9.0		
50.0	8.6	9.0	9.0		
55.0	6.6	8.3	9.0	9.0	
60.0	4.4	6.4	7.9	9.0	8.8
65.0	2.3	4.2	5.9	7.8	8.5
70.0		2.3	3.8	5.8	6.9
75.0			1.9	3.5	4.6
80.0				1.5	2.2
危険角度 (°)	59	60	60	61	61
フック種類	12t	12t	12t	12t	12t
フック質量 (t)	0.53	0.53	0.53	0.53	0.53
掛数	1	1	1	1	1

HD性能 22.7mブーム+9.4m+54mヘビーリフトジブ

オフセット	10°	20°	30°	45°	60°
作業半径 (m)	荷重 (ton)	荷重 (ton)	荷重 (ton)	荷重 (ton)	荷重 (ton)
24.0	12.0				
26.0	12.0				
28.0	12.0				
30.0	12.0				
32.0	12.0	12.0			
34.0	11.4	12.0			
36.0	10.0	12.0			
38.0	8.8	10.7			
40.0	7.7	9.4	11.2		
42.0	6.7	8.3	9.9		
44.0	5.8	7.3	8.8		
46.0	4.8	6.4	7.8		
48.0	3.9	5.6	6.9	8.8	
50.0	3.0	4.8	6.1	7.9	
55.0		2.6	4.2	5.8	7.1
60.0			2.0	3.9	5.0
65.0				1.7	2.7
危険角度 (°)	59	61	62	63	63
フック種類	12t	12t	12t	12t	12t
フック質量 (t)	0.53	0.53	0.53	0.53	0.53
掛数	1	1	1	1	1

HD性能 40.9mブーム+9.4m+54mヘビーリフトジブ

オフセット	10°	20°	30°	45°	60°
作業半径 (m)	荷重 (ton)	荷重 (ton)	荷重 (ton)	荷重 (ton)	荷重 (ton)
26.0	12.0				
28.0	12.0				
30.0	12.0				
32.0	10.9				
34.0	9.1	12.0			
36.0	7.6	10.7			
38.0	6.2	9.2			
40.0		7.9			
42.0		6.7	8.9		
44.0		5.5	7.8		
46.0			6.7		
48.0			5.7		
50.0					
55.0				5.0	
60.0					4.5
危険角度 (°)	74	75	76	77	78
フック種類	12t	12t	12t	12t	12t
フック質量 (t)	0.53	0.53	0.53	0.53	0.53
掛数	1	1	1	1	1

HD性能 31.8mブーム+9.4m+54mヘビーリフトジブ

オフセット	10°	20°	30°	45°	60°
作業半径 (m)	荷重 (ton)	荷重 (ton)	荷重 (ton)	荷重 (ton)	荷重 (ton)
24.0	12.0				
26.0	12.0				
28.0	12.0				
30.0	12.0				
32.0	12.0	12.0			
34.0	10.6	12.0			
36.0	9.2	11.5			
38.0	8.0	10.1			
40.0	6.8	8.8	10.8		
42.0	5.8	7.7	9.6		
44.0	4.7	6.7	8.4		
46.0		5.8	7.4		
48.0		4.9	6.5		
50.0		3.8	5.6	7.6	
55.0			3.4	5.5	
60.0				3.4	4.8
65.0					2.5
危険角度 (°)	67	69	70	72	72
フック種類	12t	12t	12t	12t	12t
フック質量 (t)	0.53	0.53	0.53	0.53	0.53
掛数	1	1	1	1	1

HD性能 50.0mブーム+9.4m+54mヘビーリフトジブ

オフセット	10°	20°	30°	45°	60°
作業半径 (m)	荷重 (ton)	荷重 (ton)	荷重 (ton)	荷重 (ton)	荷重 (ton)
26.0	9.0				
28.0	9.0				
30.0	9.0				
32.0	9.0				
34.0	7.9				
36.0		9.0			
38.0		8.5			
40.0		7.0			
42.0					
44.0			7.4		
46.0			6.2		
危険角度 (°)	77	78	79		
フック種類	12t	12t	12t		
フック質量 (t)	0.53	0.53	0.53		
掛数	1	1	1		

HB性能 22.7mブーム+9.4m+54mヘビーリフトジブ

オフセット	10°	20°	30°	45°	60°
作業半径 (m)	荷重 (ton)	荷重 (ton)	荷重 (ton)	荷重 (ton)	荷重 (ton)
24.0	12.0				
26.0	12.0				
28.0	12.0				
30.0	12.0				
32.0	12.0	12.0			
34.0	12.0	12.0			
36.0	12.0	12.0			
38.0	12.0	12.0			
40.0	12.0	12.0	12.0		
42.0	12.0	12.0	12.0		
44.0	11.6	12.0	12.0		
46.0	10.5	12.0	12.0		
48.0	9.3	10.9	11.8	10.4	
50.0	8.3	9.9	11.2	10.1	
55.0	5.9	7.5	8.8	9.4	8.9
60.0	4.0	5.3	6.6	8.1	8.5
65.0	2.3	3.4	4.5	5.9	6.8
70.0		1.8	2.6	3.6	
危険角度 (°)	45	45	49	54	60
フック種類	12t	12t	12t	12t	12t
フック質量 (t)	0.53	0.53	0.53	0.53	0.53
掛数	1	1	1	1	1

HB性能 40.9mブーム+9.4m+54mヘビーリフトジブ

オフセット	10°	20°	30°	45°	60°
作業半径 (m)	荷重 (ton)	荷重 (ton)	荷重 (ton)	荷重 (ton)	荷重 (ton)
26.0	12.0				
28.0	12.0				
30.0	12.0				
32.0	12.0				
34.0	12.0	12.0			
36.0	12.0	12.0			
38.0	12.0	12.0			
40.0	11.6	12.0			
42.0	10.1	12.0	12.0		
44.0	8.7	11.6	12.0		
46.0	7.4	10.2	12.0		
48.0	6.2	8.8	11.1		
50.0	5.2	7.6	9.9		
55.0	2.8	5.0	7.0	9.5	
60.0		2.7	4.5	7.0	8.6
65.0			2.4	4.5	6.1
70.0				2.3	3.4
危険角度 (°)	63	64	65	66	66
フック種類	12t	12t	12t	12t	12t
フック質量 (t)	0.53	0.53	0.53	0.53	0.53
掛数	1	1	1	1	1

HB性能 31.8mブーム+9.4m+54mヘビーリフトジブ

オフセット	10°	20°	30°	45°	60°
作業半径 (m)	荷重 (ton)	荷重 (ton)	荷重 (ton)	荷重 (ton)	荷重 (ton)
24.0	12.0				
26.0	12.0				
28.0	12.0				
30.0	12.0				
32.0	12.0	12.0			
34.0	12.0	12.0			
36.0	12.0	12.0			
38.0	12.0	12.0			
40.0	12.0	12.0	12.0		
42.0	11.9	12.0	12.0		
44.0	10.5	12.0	12.0		
46.0	9.2	11.4	12.0		
48.0	8.1	10.2	11.8		
50.0	7.0	9.1	10.7	10.3	
55.0	4.7	6.5	8.2	9.6	
60.0	2.7	4.3	5.8	7.8	8.6
65.0		2.4	3.7	5.4	6.7
70.0			1.9	3.2	4.0
危険角度 (°)	55	56	56	61	61
フック種類	12t	12t	12t	12t	12t
フック質量 (t)	0.53	0.53	0.53	0.53	0.53
掛数	1	1	1	1	1

HB性能 50.0mブーム+9.4m+54mヘビーリフトジブ

オフセット	10°	20°	30°	45°	60°
作業半径 (m)	荷重 (ton)	荷重 (ton)	荷重 (ton)	荷重 (ton)	荷重 (ton)
26.0	9.0				
28.0	9.0				
30.0	9.0				
32.0	9.0				
34.0	9.0				
36.0	9.0	9.0			
38.0	9.0	9.0			
40.0	9.0	9.0			
42.0	9.0	9.0			
44.0	7.9	9.0	9.0		
46.0	6.6	9.0	9.0		
48.0	5.4	8.2	9.0		
50.0	4.3	7.0	9.0		
55.0		4.3	6.6	9.0	
60.0			4.0	6.7	8.5
65.0				4.2	5.9
70.0					3.4
危険角度 (°)	68	69	70	71	71
フック種類	12t	12t	12t	12t	12t
フック質量 (t)	0.53	0.53	0.53	0.53	0.53
掛数	1	1	1	1	1

HC性能 22.7mブーム+9.4m+54mヘビーリフトジブ

オフセット	10°	20°	30°	45°	60°
作業半径 (m)	荷重 (ton)	荷重 (ton)	荷重 (ton)	荷重 (ton)	荷重 (ton)
24.0	12.0				
26.0	12.0				
28.0	12.0				
30.0	12.0				
32.0	12.0	12.0			
34.0	12.0	12.0			
36.0	12.0	12.0			
38.0	12.0	12.0			
40.0	10.6	12.0	12.0		
42.0	9.3	11.2	12.0		
44.0	8.1	10.1	11.6		
46.0	7.0	9.0	10.5		
48.0	6.0	7.9	9.4	10.4	
50.0	5.1	6.9	8.4	10.1	
55.0	3.1	4.6	6.1	7.9	8.9
60.0		2.7	3.9	5.7	6.9
65.0			2.0	3.4	4.4
危険角度 (°)	55	56	56	60	60
フック種類	12t	12t	12t	12t	12t
フック質量 (t)	0.53	0.53	0.53	0.53	0.53
掛数	1	1	1	1	1

HC性能 40.9mブーム+9.4m+54mヘビーリフトジブ

オフセット	10°	20°	30°	45°	60°
作業半径 (m)	荷重 (ton)	荷重 (ton)	荷重 (ton)	荷重 (ton)	荷重 (ton)
26.0	12.0				
28.0	12.0				
30.0	12.0				
32.0	12.0				
34.0	12.0	12.0			
36.0	10.8	12.0			
38.0	9.1	12.0			
40.0	7.7	10.9			
42.0	6.3	9.4	11.9		
44.0	5.1	8.0	10.5		
46.0	4.0	6.7	9.3		
48.0		5.5	8.0		
50.0		4.5	6.8		
55.0			4.1	7.0	
60.0				4.4	6.3
65.0					3.6
危険角度 (°)	69	70	71	72	73
フック種類	12t	12t	12t	12t	12t
フック質量 (t)	0.53	0.53	0.53	0.53	0.53
掛数	1	1	1	1	1

HC性能 31.8mブーム+9.4m+54mヘビーリフトジブ

オフセット	10°	20°	30°	45°	60°
作業半径 (m)	荷重 (ton)	荷重 (ton)	荷重 (ton)	荷重 (ton)	荷重 (ton)
24.0	12.0				
26.0	12.0				
28.0	12.0				
30.0	12.0				
32.0	12.0	12.0			
34.0	12.0	12.0			
36.0	12.0	12.0			
38.0	10.9	12.0			
40.0	9.4	11.9	12.0		
42.0	8.1	10.6	12.0		
44.0	6.9	9.3	11.2		
46.0	5.8	8.1	10.0		
48.0	4.8	7.0	8.9		
50.0	3.9	5.9	7.9	10.0	
55.0		3.6	5.3	7.6	
60.0			3.2	5.2	6.7
65.0				3.0	4.2
70.0					1.8
危険角度 (°)	61	62	64	65	65
フック種類	12t	12t	12t	12t	12t
フック質量 (t)	0.53	0.53	0.53	0.53	0.53
掛数	1	1	1	1	1

HC性能 50.0mブーム+9.4m+54mヘビーリフトジブ

オフセット	10°	20°	30°	45°	60°
作業半径 (m)	荷重 (ton)	荷重 (ton)	荷重 (ton)	荷重 (ton)	荷重 (ton)
26.0	9.0				
28.0	9.0				
30.0	9.0				
32.0	9.0				
34.0	9.0				
36.0	9.0	9.0			
38.0	8.4	9.0			
40.0	6.9	9.0			
42.0	5.5	8.8			
44.0		7.4	9.0		
46.0		6.1	9.0		
48.0		4.9	7.6		
50.0			6.4		
55.0				6.8	
60.0				4.1	6.2
65.0					3.5
危険角度 (°)	73	74	75	76	76
フック種類	12t	12t	12t	12t	12t
フック質量 (t)	0.53	0.53	0.53	0.53	0.53
掛数	1	1	1	1	1

HA性能 22.7mブーム+9.4m+63mヘビーリフトジブ

オフセット	10°	20°	30°	45°	60°
作業半径 (m)	荷重 (ton)	荷重 (ton)	荷重 (ton)	荷重 (ton)	荷重 (ton)
26.0	12.0				
28.0	12.0				
30.0	12.0				
32.0	12.0				
34.0	12.0				
36.0	12.0	11.6			
38.0	11.6	11.3			
40.0	11.2	10.9			
42.0	10.8	10.6			
44.0	10.5	10.3	9.6		
46.0	10.2	10.0	9.4		
48.0	9.9	9.7	9.1		
50.0	9.6	9.4	8.9		
55.0	8.9	8.8	8.4	7.8	
60.0	8.3	8.3	7.9	7.1	
65.0	7.1	7.8	7.3	6.6	6.3
70.0	5.4	6.5	6.7	6.2	6.0
75.0	3.8	4.8	5.8	5.8	5.8
80.0	2.5	3.3	4.1	5.0	
85.0		1.9	2.4		
危険角度 (°)	35	35	35	45	60
フック種類	12t	12t	12t	12t	12t
フック質量 (t)	0.53	0.53	0.53	0.53	0.53
掛数	1	1	1	1	1

HA性能 40.9mブーム+9.4m+63mヘビーリフトジブ

オフセット	10°	20°	30°	45°	60°
作業半径 (m)	荷重 (ton)	荷重 (ton)	荷重 (ton)	荷重 (ton)	荷重 (ton)
28.0	10.0				
30.0	10.0				
32.0	10.0				
34.0	10.0				
36.0	10.0				
38.0	10.0	10.0			
40.0	10.0	10.0			
42.0	10.0	10.0			
44.0	10.0	10.0			
46.0	10.0	10.0			
48.0	10.0	10.0	9.5		
50.0	10.0	10.0	9.3		
55.0	8.4	9.5	8.8		
60.0	6.0	8.2	8.4	7.5	
65.0	4.0	5.9	7.8	7.0	
70.0	2.2	4.0	5.6	6.6	6.2
75.0		2.2	3.7	5.7	6.0
80.0			2.0	3.7	4.8
85.0				1.8	2.5
危険角度 (°)	55	56	57	57	60
フック種類	12t	12t	12t	12t	12t
フック質量 (t)	0.53	0.53	0.53	0.53	0.53
掛数	1	1	1	1	1

HA性能 31.8mブーム+9.4m+63mヘビーリフトジブ

オフセット	10°	20°	30°	45°	60°
作業半径 (m)	荷重 (ton)	荷重 (ton)	荷重 (ton)	荷重 (ton)	荷重 (ton)
28.0	12.0				
30.0	12.0				
32.0	12.0				
34.0	12.0				
36.0	12.0				
38.0	12.0	11.5			
40.0	11.7	11.2			
42.0	11.4	10.9			
44.0	11.0	10.6			
46.0	10.7	10.3	9.6		
48.0	10.4	10.0	9.3		
50.0	10.1	9.8	9.1		
55.0	9.4	9.2	8.6		
60.0	7.8	8.5	8.1	7.3	
65.0	5.8	7.4	7.8	6.8	6.4
70.0	4.1	5.5	6.9	6.4	6.1
75.0	2.6	3.8	5.0	6.0	5.9
80.0		2.3	3.3	4.6	5.3
85.0			1.8	2.7	
危険角度 (°)	46	47	47	50	60
フック種類	12t	12t	12t	12t	12t
フック質量 (t)	0.53	0.53	0.53	0.53	0.53
掛数	1	1	1	1	1

HA性能 50.0mブーム+9.4m+63mヘビーリフトジブ

オフセット	10°	20°	30°	45°	60°
作業半径 (m)	荷重 (ton)	荷重 (ton)	荷重 (ton)	荷重 (ton)	荷重 (ton)
30.0	7.0				
32.0	7.0				
34.0	7.0				
36.0	7.0				
38.0	7.0				
40.0	7.0	7.0			
42.0	7.0	7.0			
44.0	7.0	7.0			
46.0	7.0	7.0			
48.0	7.0	7.0			
50.0	7.0	7.0	7.0		
55.0	6.5	7.0	7.0		
60.0	4.9	6.6	7.0	7.0	
65.0	3.1	5.0	6.6	7.0	
70.0		3.3	4.9	6.8	6.3
75.0			3.2	5.2	6.0
80.0				3.3	4.7
85.0				1.5	2.5
危険角度 (°)	62	63	64	64	65
フック種類	12t	12t	12t	12t	12t
フック質量 (t)	0.53	0.53	0.53	0.53	0.53
掛数	1	1	1	1	1

HD性能 22.7mブーム+9.4m+63mヘビーリフトジブ

オフセット	10°	20°	30°	45°	60°
作業半径 (m)	荷重 (ton)	荷重 (ton)	荷重 (ton)	荷重 (ton)	荷重 (ton)
26.0	12.0				
28.0	12.0				
30.0	12.0				
32.0	12.0				
34.0	12.0				
36.0	10.6	11.6			
38.0	9.4	11.3			
40.0	8.3	10.2			
42.0	7.3	9.1			
44.0	6.4	8.1	9.6		
46.0	5.5	7.2	8.8		
48.0	4.7	6.3	7.9		
50.0	3.7	5.6	7.0		
55.0		3.6	5.1	7.0	
60.0			3.3	5.2	
65.0				3.5	4.8
70.0					3.0
危険角度 (°)	62	64	66	68	68
フック種類	12t	12t	12t	12t	12t
フック質量 (t)	0.53	0.53	0.53	0.53	0.53
掛数	1	1	1	1	1

HD性能 40.9mブーム+9.4m+63mヘビーリフトジブ

オフセット	10°	20°	30°	45°	60°
作業半径 (m)	荷重 (ton)	荷重 (ton)	荷重 (ton)	荷重 (ton)	荷重 (ton)
28.0	10.0				
30.0	10.0				
32.0	10.0				
34.0	9.8				
36.0	8.3				
38.0	6.9	10.0			
40.0		9.0			
42.0		7.7			
44.0		6.5			
46.0		5.4			
48.0			6.9		
50.0			6.0		
危険角度 (°)	76	77	78		
フック種類	12t	12t	12t		
フック質量 (t)	0.53	0.53	0.53		
掛数	1	1	1		

HD性能 31.8mブーム+9.4m+63mヘビーリフトジブ

オフセット	10°	20°	30°	45°	60°
作業半径 (m)	荷重 (ton)	荷重 (ton)	荷重 (ton)	荷重 (ton)	荷重 (ton)
28.0	12.0				
30.0	12.0				
32.0	12.0				
34.0	11.3				
36.0	9.9				
38.0	8.6	11.0			
40.0	7.5	9.7			
42.0	6.5	8.6			
44.0	5.5	7.5			
46.0	4.4	6.6	8.4		
48.0		5.7	7.5		
50.0		4.9	6.6		
55.0			4.7		
60.0				4.9	
65.0				3.1	4.6
70.0					2.7
危険角度 (°)	69	71	73	74	75
フック種類	12t	12t	12t	12t	12t
フック質量 (t)	0.53	0.53	0.53	0.53	0.53
掛数	1	1	1	1	1

HD性能 50.0mブーム+9.4m+63mヘビーリフトジブ

オフセット	10°	20°	30°	45°	60°
作業半径 (m)	荷重 (ton)	荷重 (ton)	荷重 (ton)	荷重 (ton)	荷重 (ton)
30.0	7.0				
32.0	7.0				
34.0	7.0				
36.0					
38.0					
40.0		7.0			
42.0		6.8			
危険角度 (°)	79	80			
フック種類	12t	12t			
フック質量 (t)	0.53	0.53			
掛数	1	1			

HB性能 22.7mブーム+9.4m+63mヘビーリフトジブ

オフセット	10°	20°	30°	45°	60°
作業半径 (m)	荷重 (ton)	荷重 (ton)	荷重 (ton)	荷重 (ton)	荷重 (ton)
26.0	12.0				
28.0	12.0				
30.0	12.0				
32.0	12.0				
34.0	12.0				
36.0	12.0	11.6			
38.0	11.6	11.3			
40.0	11.2	10.9			
42.0	10.8	10.6			
44.0	10.5	10.3	9.6		
46.0	10.2	10.0	9.4		
48.0	9.9	9.7	9.1		
50.0	8.9	9.4	8.9		
55.0	6.6	8.4	8.4	7.8	
60.0	4.7	6.2	7.7	7.1	
65.0	3.0	4.4	5.7	6.6	6.3
70.0	1.6	2.7	3.9	5.5	6.0
75.0			2.3	3.5	4.3
80.0				1.7	
危険角度 (°)	47	53	53	53	60
フック種類	12t	12t	12t	12t	12t
フック質量 (t)	0.53	0.53	0.53	0.53	0.53
掛数	1	1	1	1	1

HB性能 40.9mブーム+9.4m+63mヘビーリフトジブ

オフセット	10°	20°	30°	45°	60°
作業半径 (m)	荷重 (ton)	荷重 (ton)	荷重 (ton)	荷重 (ton)	荷重 (ton)
28.0	10.0				
30.0	10.0				
32.0	10.0				
34.0	10.0				
36.0	10.0				
38.0	10.0	10.0			
40.0	10.0	10.0			
42.0	10.0	10.0			
44.0	9.5	10.0			
46.0	8.2	10.0			
48.0	7.1	10.0	9.5		
50.0	6.0	8.8	9.3		
55.0	3.6	6.1	8.5		
60.0		3.8	5.9	7.5	
65.0			3.7	6.4	
70.0				4.1	6.0
75.0				2.1	3.6
危険角度 (°)	65	67	68	69	70
フック種類	12t	12t	12t	12t	12t
フック質量 (t)	0.53	0.53	0.53	0.53	0.53
掛数	1	1	1	1	1

HB性能 31.8mブーム+9.4m+63mヘビーリフトジブ

オフセット	10°	20°	30°	45°	60°
作業半径 (m)	荷重 (ton)	荷重 (ton)	荷重 (ton)	荷重 (ton)	荷重 (ton)
28.0	12.0				
30.0	12.0				
32.0	12.0				
34.0	12.0				
36.0	12.0				
38.0	12.0	11.5			
40.0	11.7	11.2			
42.0	11.4	10.9			
44.0	11.0	10.6			
46.0	10.0	10.3	9.6		
48.0	8.8	10.0	9.3		
50.0	7.7	9.8	9.1		
55.0	5.4	7.5	8.6		
60.0	3.4	5.2	7.0	7.3	
65.0	1.7	3.4	4.9	6.8	6.4
70.0		1.7	3.1	5.0	6.1
75.0				3.1	4.2
80.0					2.0
危険角度 (°)	56	57	63	63	63
フック種類	12t	12t	12t	12t	12t
フック質量 (t)	0.53	0.53	0.53	0.53	0.53
掛数	1	1	1	1	1

HB性能 50.0mブーム+9.4m+63mヘビーリフトジブ

オフセット	10°	20°	30°	45°	60°
作業半径 (m)	荷重 (ton)	荷重 (ton)	荷重 (ton)	荷重 (ton)	荷重 (ton)
30.0	7.0				
32.0	7.0				
34.0	7.0				
36.0	7.0				
38.0	7.0				
40.0	7.0	7.0			
42.0	7.0	7.0			
44.0	7.0	7.0			
46.0	7.0	7.0			
48.0	6.2	7.0			
50.0	5.1	7.0	7.0		
55.0		5.4	7.0		
60.0			5.4	7.0	
65.0			3.2	6.1	
70.0				3.8	5.9
75.0					3.5
危険角度 (°)	70	71	72	74	74
フック種類	12t	12t	12t	12t	12t
フック質量 (t)	0.53	0.53	0.53	0.53	0.53
掛数	1	1	1	1	1

HC性能 22.7mブーム+9.4m+63mヘビーリフトジブ

オフセット	10°	20°	30°	45°	60°
作業半径 (m)	荷重 (ton)	荷重 (ton)	荷重 (ton)	荷重 (ton)	荷重 (ton)
26.0	12.0				
28.0	12.0				
30.0	12.0				
32.0	12.0				
34.0	12.0				
36.0	12.0	11.6			
38.0	11.6	11.3			
40.0	11.2	10.9			
42.0	10.0	10.6			
44.0	8.8	10.3	9.6		
46.0	7.7	9.8	9.4		
48.0	6.7	8.8	9.1		
50.0	5.8	7.8	8.9		
55.0	3.7	5.5	7.2	7.8	
60.0	2.0	3.6	5.1	7.1	
65.0		1.9	3.2	5.1	6.3
70.0			1.6	3.2	4.5
75.0					2.2
危険角度 (°)	56	58	59	65	65
フック種類	12t	12t	12t	12t	12t
フック質量 (t)	0.53	0.53	0.53	0.53	0.53
掛数	1	1	1	1	1

HC性能 40.9mブーム+9.4m+63mヘビーリフトジブ

オフセット	10°	20°	30°	45°	60°
作業半径 (m)	荷重 (ton)	荷重 (ton)	荷重 (ton)	荷重 (ton)	荷重 (ton)
28.0	10.0				
30.0	10.0				
32.0	10.0				
34.0	10.0				
36.0	10.0				
38.0	10.0	10.0			
40.0	8.5	10.0			
42.0	7.2	10.0			
44.0	5.9	9.2			
46.0	4.8	7.9			
48.0		6.7	9.4		
50.0		5.6	8.3		
55.0			5.6		
60.0				6.3	
65.0				3.9	
70.0					3.7
危険角度 (°)	71	73	74	75	75
フック種類	12t	12t	12t	12t	12t
フック質量 (t)	0.53	0.53	0.53	0.53	0.53
掛数	1	1	1	1	1

HC性能 31.8mブーム+9.4m+63mヘビーリフトジブ

オフセット	10°	20°	30°	45°	60°
作業半径 (m)	荷重 (ton)	荷重 (ton)	荷重 (ton)	荷重 (ton)	荷重 (ton)
28.0	12.0				
30.0	12.0				
32.0	12.0				
34.0	12.0				
36.0	12.0				
38.0	11.7	11.5			
40.0	10.2	11.2			
42.0	8.8	10.9			
44.0	7.6	10.3			
46.0	6.5	9.1	9.6		
48.0	5.5	8.0	9.3		
50.0	4.6	6.9	9.0		
55.0	2.5	4.6	6.6		
60.0		2.6	4.4	6.8	
65.0			2.5	4.7	6.4
70.0				2.7	4.2
75.0					2.1
危険角度 (°)	64	65	67	68	69
フック種類	12t	12t	12t	12t	12t
フック質量 (t)	0.53	0.53	0.53	0.53	0.53
掛数	1	1	1	1	1

HC性能 50.0mブーム+9.4m+63mヘビーリフトジブ

オフセット	10°	20°	30°	45°	60°
作業半径 (m)	荷重 (ton)	荷重 (ton)	荷重 (ton)	荷重 (ton)	荷重 (ton)
30.0	7.0				
32.0	7.0				
34.0	7.0				
36.0	7.0				
38.0	7.0				
40.0	7.0	7.0			
42.0	6.4	7.0			
44.0		7.0			
46.0		7.0			
48.0		6.1			
50.0		5.0	7.0		
55.0			5.1		
60.0				6.0	
65.0					
70.0					3.6
危険角度 (°)	75	76	77	79	79
フック種類	12t	12t	12t	12t	12t
フック質量 (t)	0.53	0.53	0.53	0.53	0.53
掛数	1	1	1	1	1